

Operator Manual

English language version.



WARNING



The MX19 Machine has been re-assessed to ensure compliance to the Machinery Directive (2006/42/EC).

The Machine rating has been changed from:

Windspeed rating of 12.5 m/s (Beaufort 6)

To

Windspeed rating of 7 m/s (Beaufort 4)

Please attach to the front cover of
your MX19 manual

510328-000

Manual part number 503726-002-EN for serial numbers 50870 to 53195

MX19

Serial Numbers 50870 – Current

ENGLISH

When contacting UpRight for service or parts information, be sure to include the MODEL and SERIAL NUMBERS from the equipment nameplate. Should the nameplate be missing, the SERIAL NUMBER is also stamped on top of the chassis above the front axle pivot.

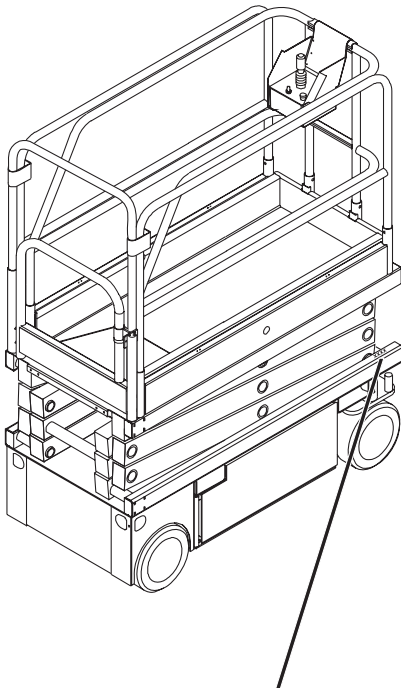

Stamped Serial Number

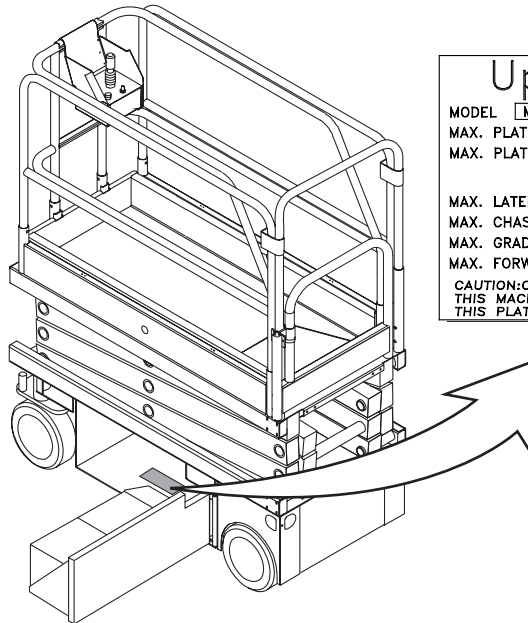

UpRight		VIGO CENTRE WASHINGTON TYNE & WEAR, UK	CE
MODEL	MX 19	SERIAL No.	
MAX. PLATFORM HEIGHT	5.8m	UNLADEN WEIGHT	1365 Kg
MAX. PLATFORM LOAD	227 Kg = 2 Persons Indoor + Equipment 1 Persons Outdoor		
MAX. LATERAL FORCE	400N Indoor 200N Outside	MAX. WIND SPEED	12.5 m/s
MAX. CHASSIS INCLINATION	2°	BATTERY VOLTAGE	24V
MAX. GRADEABILITY	25%	CHARGER INPUT VOLTAGE	110/220V
MAX. FORWARD SPEED	1.0 m/s	NOMINAL POWER	3kW
CAUTION: ONLY TRAINED & AUTHORISED PERSONNEL MAY USE THIS MACHINE—CONSULT OPERATORS MANUAL BEFORE USE. THIS PLATFORM IS NOT ELECTRICALLY INSULATED 503725-000			



OPERATION MANUAL

WARNING

All personnel shall carefully read, understand and follow all safety rules and operating instructions before operating or performing maintenance on any UpRight aerial work platform.

Safety Rules

Electrocution Hazard

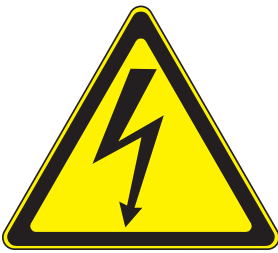

THIS MACHINE IS NOT INSULATED!

Tip Over Hazard

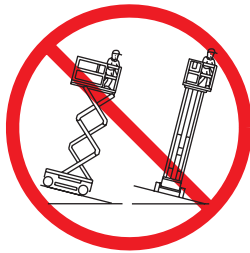

NEVER elevate the platform or drive the machine while elevated unless the machine is on a firm, level surface.

Collision Hazard



NEVER position the platform without first checking for overhead obstructions or other hazards.

Fall Hazard

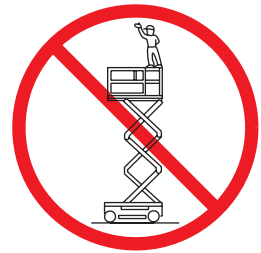

NEVER climb, stand, or sit on platform guardrails or midrail.

USE OF THE AERIAL WORK PLATFORM: This aerial work platform is intended to lift persons and his tools as well as the material used for the job. It is designed for repair and assembly jobs and assignments at overhead workplaces (ceilings, cranes, roof structures, buildings etc.). All other uses of the aerial work platform are prohibited!

THIS AERIAL WORK PLATFORM IS NOT INSULATED! For this reason it is imperative to keep a safe distance from live parts of electrical equipment!

Exceeding the specified permissible maximum load **is prohibited!** See "Special Limitations" on page 4 for details.

The use and operation of the aerial work platform as a lifting tool or a crane (lifting of loads from below upwards or from up high on down) **is prohibited!**

NEVER exceed the manual force allowed for this machine. See "Special Limitations" on page 4 for details.

DISTRIBUTE all platform loads evenly on the platform.

NEVER operate the machine without first surveying the work area for surface hazards such as holes, drop-offs, bumps, curbs, or debris; and avoiding them.

OPERATE machine only on surfaces capable of supporting wheel loads.

NEVER operate the machine when wind speeds exceed this machine's wind rating. See "Beaufort Scale" on page 4 for details.

IN CASE OF EMERGENCY push EMERGENCY STOP switch to deactivate all powered functions.

IF ALARM SOUNDS while platform is elevated, STOP, carefully lower platform. Move machine to a firm, level surface.

Climbing up the railing of the platform, standing on or stepping from the platform onto buildings, steel or prefab concrete structures, etc., **is prohibited!**

Dismantling the swing gate or other railing components **is prohibited!** Always make certain that the swing gate is closed and securely locked!

It is prohibited to keep the swing gate in an open position (held open with tie-straps) when the platform is raised!

To extend the height or the range by placing of ladders, scaffolds or similar devices on the platform **is prohibited!**

NEVER perform service on machine while platform is elevated without blocking elevating assembly.

INSPECT the machine thoroughly for cracked welds, loose or missing hardware, hydraulic leaks, loose wire connections, and damaged cables or hoses before using.

VERIFY that all labels are in place and legible before using.

NEVER use a machine that is damaged, not functioning properly, or has damaged or missing labels.

To bypass any safety equipment **is prohibited** and presents a danger for the persons on the aerial work platform and in its working range.

NEVER charge batteries near sparks or open flame. Charging batteries emit explosive hydrogen gas.

Modifications to the aerial work platform **are prohibited** or permissible only at the approval by UpRight .

AFTER USE, secure the work platform from unauthorized use by turning both keyswitches off and removing key.

CONTENTS

Introduction	3
General Description	3
Special Limitations	4
Platform Capacity	4
Manual Force	4
Beaufort Scale	4
Lift Overload Alarm	4
Controls and Indicators	5
Pre-Operation Safety Inspection	6
System Function Inspection	7
Operation	8
Platform Extension	8
Travel With the Platform Lowered	8
Steering	8
Elevating the Platform	9
Travel With the Platform Elevated	9
Lowering the Platform	9
Emergency Lowering	9
After Use Each Day	10
Hour Meter	10
Transporting the Work Platform	11
By Crane	11
By Forklift	11
By Truck	11
Maintenance	12
Blocking The Elevating Assembly	12
Scissor Brace Installation	12
Scissor Brace Stowage	12
Battery Maintenance	13
Battery Charging	13
Inspection and Maintenance Schedule	14
Daily Preventative Maintenance Checklist	14
Interval	14
Specifications	15

INTRODUCTION

This manual covers the application of the MX Series Self-Propelled Work Platforms. **This manual must be stored on the machine at all times.**

GENERAL DESCRIPTION

1. Platform
2. Deck Extension

⚠ WARNING ⚠

DO NOT use the maintenance platform without guardrails properly assembled and in place

3. Platform Controls
4. Manual Case
5. Elevating Assembly
6. Chassis

Figure 1: MX Series

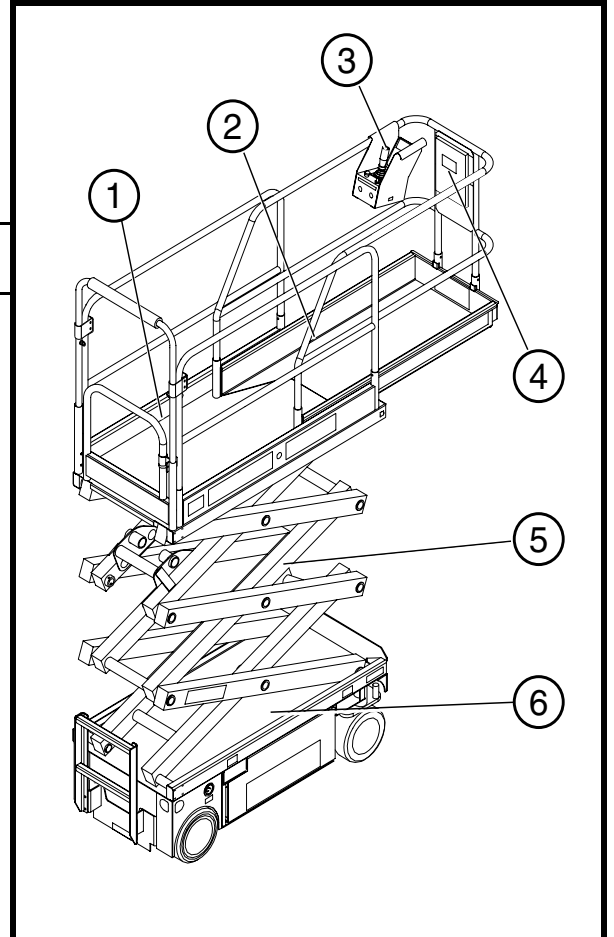

SPECIAL LIMITATIONS

Travel with the platform raised is limited to creep speed range.

Elevating the platform is limited to firm, level surfaces only.

⚠ DANGER ⚠

The elevating function shall ONLY be used when the work platform is level and on a firm surface.

The work platform is NOT intended to be driven over uneven, rough, or soft terrain.

PLATFORM CAPACITY

The maximum platform capacity for the MX 19 is 227 kg (500 lbs). Two people may occupy the platform indoors, while only one may occupy the platform outdoors.

⚠ DANGER ⚠

DO NOT exceed the maximum platform capacity or the platform occupancy limits for this machine.

MANUAL FORCE

Manual force is the force applied by the occupants to objects such as walls or other structures outside the work platform.

The maximum allowable manual force is limited to 200 N (45 lbs.) of force per occupant, with a maximum of 400 N (90 lbs.) for two occupants.

⚠ DANGER ⚠

DO NOT exceed the maximum amount of manual force for this machine.

BEAUFORT SCALE

Never operate the machine when wind speeds exceed 12.5 m/s (28mph) [Beaufort scale 6].

BEAUFORT RATING	WIND SPEED				GROUND CONDITIONS
	m/s	km/h	ft/s	mph	
3	3,4~5,4	12,25~19,4	11.5~17.75	7.5~12.0	Papers and thin branches move, flags wave.
4	5,4~8,0	19,4~28,8	17.75~26.25	12.0~18	Dust is raised, paper whirls up, and small branches sway.
5	8,0~10,8	28,8~38,9	26.25~35.5	18~24.25	Shrubs with leaves start swaying. Wave crests are apparent in ponds or swamps.
6	10,8~13,9	38,9~50,0	35.5~45.5	24.5~31	Tree branches move. Power lines whistle. It is difficult to open an umbrella.
7	13,9~17,2	50,0~61,9	45.5~56.5	31.-38.5	Whole trees sway. It is difficult to walk against the wind.

LIFT OVERLOAD ALARM

If a load equivalent to 90% of safe working load is lifted a fault code "03" will be displayed on the digital display on the platform control box. If a load which is greater than the safe working load is present in the basket all machine functions will cease to operate and an acoustic warning will sound. In order to return to normal operation a load equal to or less than the safe working load must be present in the basket and the power must be re-cycled, power can be re-cycled by pushing the emergency stop button and releasing it again.

⚠ DANGER ⚠

Never operate the machine with a platform load greater than the rated capacity.

CONTROLS AND INDICATORS

Figure 2: Controls and Indicators

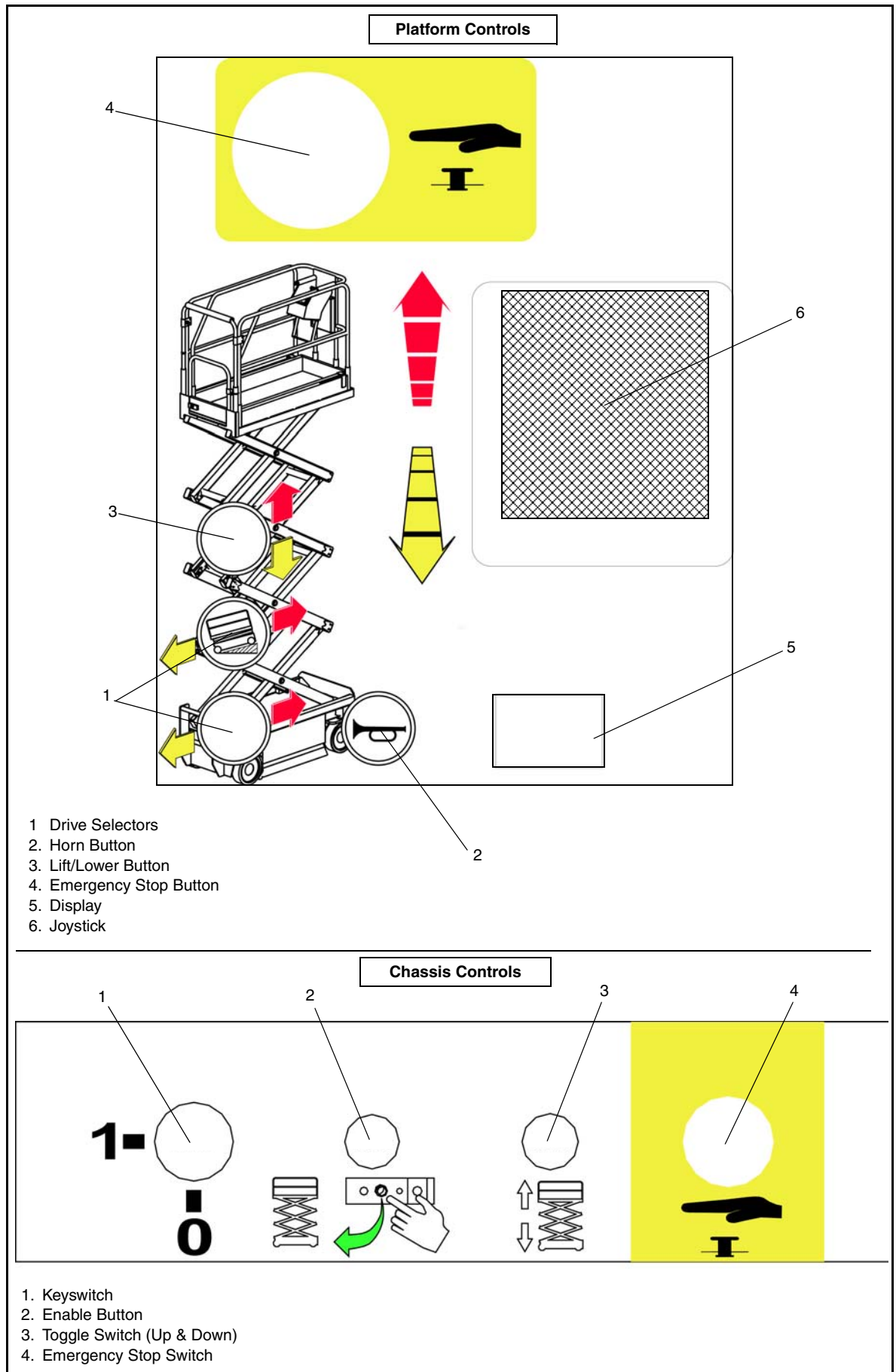

PRE-OPERATION SAFETY INSPECTION

NOTE: Carefully read, understand and follow all safety rules, operating instructions, labels and National Safety Instructions/Requirements. Perform the following steps each day before use.

1. Open modules and inspect for damage, fluid leaks or missing parts.

Figure 3: Hydraulic Tank

2. Check the level of the hydraulic fluid with the platform fully lowered. The hydraulic reservoir is located at the rear of the machine. The fluid level should be visible through the side of the tank, and must be between the MIN and MAX lines (see Figure 3). Add hydraulic fluid if necessary.
3. Check that fluid level in the batteries is correct (See Battery Maintenance, page 9).
4. Verify that batteries are charged.
5. Check that A.C. extension cord has been disconnected from the plug in the left Chassis Module, and that the module doors are closed and locked.

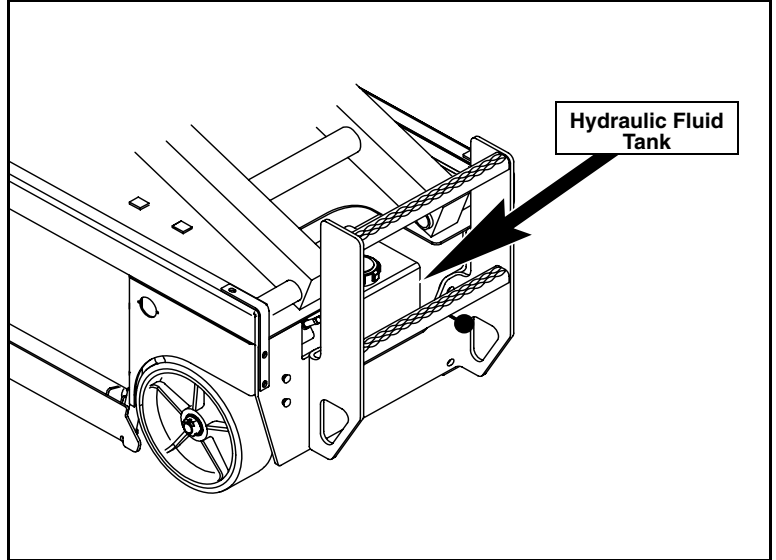

6. Check that all guardrails are in place and all fasteners are properly tightened.
7. Inspect the machine thoroughly for cracked welds and structural damage, loose or missing hardware, hydraulic leaks, damaged control cable, loose wire connections and wheel bolts.

SYSTEM FUNCTION INSPECTION

Refer to Figure 2 for the locations of various controls and indicators.

! WARNING !

STAND CLEAR of the work platform while performing the following checks.

Before operating the work platform, survey the work area for surface hazards such as holes, drop-offs, bumps and debris.

Check in **ALL** directions, including above the work platform, for obstructions and electrical conductors.

Protect the control console cable from possible damage while performing checks.

1. Move the machine, if necessary, to an unobstructed area to allow for full elevation.
2. Twist Chassis Emergency Stop Switch to the ON position.
3. Twist Platform Emergency Stop Switch to the ON position.
4. Turn the Chassis Key Switch to ON. Push the Chassis Lift/Lower Switch to the UP position and raise the platform approximately 2,1 m (7 feet). **BLOCK THE ELEVATING ASSEMBLY AS DESCRIBED ON page 12.**
5. Visually inspect the elevating assembly, lift cylinder, cables, and hoses for cracked welds and structural damage, loose hardware, hydraulic leaks, loose wire connections, and erratic operation. Check for missing or loose parts.
6. Verify that the Depression Mechanism Supports have rotated into position under the machine. **REMOVE THE SCISSOR BRACE AS DESCRIBED ON page 12.**
7. Push the Chassis Lift/Lower Switch to the UP position and fully elevate the platform. Partially lower the platform by pushing Chassis Lift/Lower Switch to LOWER, and check for proper operation of the audible lowering alarm.
8. Open the Emergency Lowering Valve (see Figure 3) by pulling the knob out to check for proper operation. When the platform is lowered, release the knob.
9. Push the Chassis Emergency Stop Switch to check for proper operation. All machine functions should be disabled. Twist the Chassis Emergency Stop Switch to resume.
10. Mount the platform.
11. Check that route is clear of obstacles (persons, obstructions, holes, and drop-offs, bumps and debris), is level, and is capable of supporting the wheel loads.
12. Mount the platform and properly close the entrance.
13. Select DRIVE mode. While engaging the Interlock Switch, move the Control Handle to FORWARD, then REVERSE, to check for speed control.
14. Push the Steering Switch RIGHT, then LEFT, to check for steering control.
15. Select LIFT mode. Grasp the Control Handle, engaging the Interlock Switch, and push it forward to check platform lift controls. Raise the platform to full elevation.
16. Pull back on the Control Handle. The platform should descend and the audible lowering alarm should sound.
17. Push the Platform Emergency Stop Switch to check for proper operation. All machine functions should be disabled. Pull out the Platform Emergency Stop Switch to resume.

OPERATION

Before operating the work platform, ensure that the Pre-Operation Safety Inspection has been completed and that any deficiencies have been corrected. **Never operate a damaged or malfunctioning machine.** The operator must be thoroughly trained on this machine.

PLATFORM EXTENSION

1. Mount the platform and properly close the entrance.
2. Depress the foot lever located at the rear of the platform extension. Push the platform extension forward until the pin engages the front stop.
3. To retract the platform extension, depress the foot lever and pull the platform extension toward the rear of the machine until the pin engages the rear stop.

Figure 4: Platform Extension

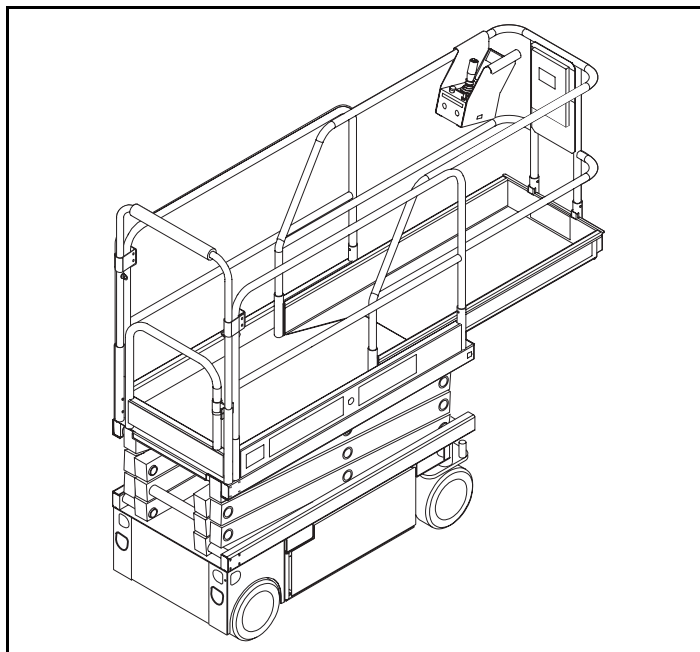

TRAVEL WITH THE PLATFORM LOWERED

1. Check that the route is clear of obstacles (persons, obstructions, holes, drop-offs, bumps, and debris), is level, and is capable of supporting the wheel loads.
2. Verify that the Chassis Key Switch is turned to DECK and Chassis Emergency Stop Switch is ON (pulled out).
3. Mount the platform and properly close the entrance.
4. Check clearances above, below, and to the sides of platform.
5. Pull the Platform Emergency Stop Switch out to the ON position.
6. Turn the Drive/Lift Switch to DRIVE.
7. Engage the Interlock Switch and move the Control Handle to FORWARD or REVERSE to travel in the desired direction. The speed of the machine will vary depending on how far from center the Control Handle is moved.

STEERING

1. Turn the Drive/Lift Switch to DRIVE.
2. While engaging the Interlock Switch, push the Steering Switch to RIGHT or LEFT to turn the wheels in the desired direction. Observe the tires while maneuvering the work platform to ensure proper direction.

NOTE: Steering is not self-centering. Wheels must be returned to the straight ahead position by operating the Steering Switch.

ELEVATING THE PLATFORM

1. Select a firm, level surface.
2. Select LIFT mode.
3. While engaging the Interlock Switch, push the Control Handle forward.
4. If the machine is not level the tilt alarm will sound and the machine will not lift or drive. **If the tilt alarm sounds the platform must be lowered and the machine moved to a firm level surface before attempting to re-elevate the platform.**

NOTE: Depression Mechanism supports will deploy automatically as the platform elevates and will retract after the platform has been lowered completely and has been driven.

TRAVEL WITH THE PLATFORM ELEVATED

NOTE: The machine will travel at reduced speed when the platform is elevated.

1. Check that the route is clear of obstacles (persons, obstructions, holes, drop-offs, bumps, and debris), is level, and is capable of supporting the wheel loads.
2. Check clearances above, below, and to the sides of platform.
3. Select DRIVE mode.
4. Engage the Interlock Switch and move the Control Handle to FORWARD or REVERSE to travel in the desired direction. The speed of the machine will vary depending on how far from center the Control Handle is moved.
5. If the machine is not level the tilt alarm will sound and the machine will not lift or drive. **If the tilt alarm sounds the platform must be lowered and the machine moved to a firm, level surface before attempting to re-elevate the platform.**

LOWERING THE PLATFORM

1. Select LIFT mode.
2. Check around the base of the platform to ensure that no one is in contact with the machine. Engage the Interlock Switch and pull back on the Control Handle to lower the platform.
3. The platform will stop when it reaches the PPE cutout height. Inspect around the machine to ensure no one is in contact with the machine. After a four-second time delay, lower the platform as in step 2.

EMERGENCY LOWERING

! WARNING !

If the platform should fail to lower, NEVER climb down the elevating assembly.

Stand clear of the elevating assembly while operating the Emergency Lowering Valve Knob.

The Emergency Lowering Valve Knob is located beside the ladder at the rear of the machine.

1. Open the Emergency Lowering Valve by pulling and holding the knob.
2. To close, release the knob. The platform will not elevate if the Emergency Lowering Valve is open.

Figure 5: Emergency Lowering

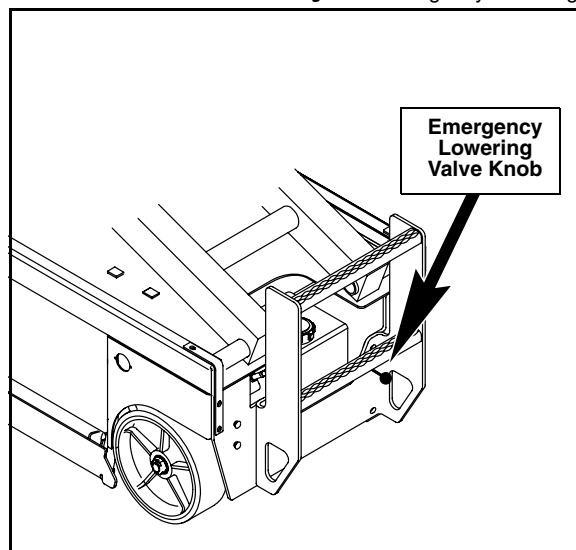

! WARNING !

Never tow faster than 0,3 m/sec. (1 ft./sec.).

AFTER USE EACH DAY

1. Ensure that the platform is fully lowered.
2. Park the machine on a firm level surface, preferably under cover, secure against vandals, children and unauthorized operation.
3. Turn the Chassis Key Switch to OFF and remove the key to prevent unauthorized operation.

HOOR METER

To access the hour meter function perform the following steps.

1. Climb into the basket (with the machine powered up)
2. Push the platform emergency stop button.
3. Hold down the following buttons, Jib and Upper Boom Lift.
4. While holding the buttons twist the emergency stop button to return power to the machine.
5. "hr" will now be displayed on the readout, Pressing the right turn button will scroll through the accumulated hours two digits at a time. For example, if pressing the right turn button once displays "20", pressing it a 2nd time displays "58", and pressing it a 3rd time displays "hr", the elapsed time of operation is 2058 hours.

TRANSPORTING THE WORK PLATFORM

BY CRANE

Secure the straps to Tie Down/Lifting D-Rings only.

BY FORKLIFT

⚠ DANGER ⚠

Forklifting is for transport only.

See specifications for weight of work platform and be certain that forklift is of adequate capacity to lift the work platform.

The MX19 may be forklifted from the rear end of the machine between the wheels. It can also be forklifted from the side using the forklift pockets shown in the diagram.

Figure 6: Transporting the Work Platform

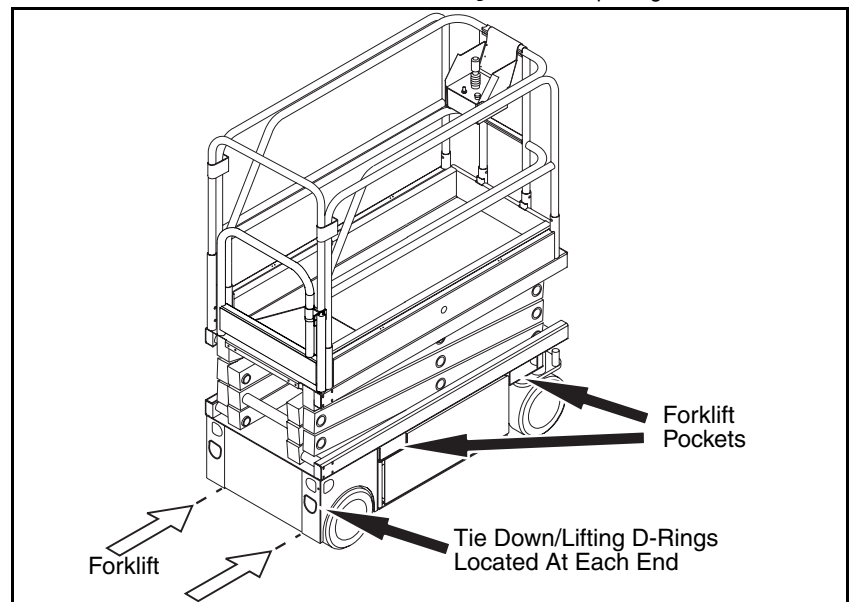

BY TRUCK

Maneuver the work platform into transport position and chock the wheels. Secure the work platform to the transport vehicle by attaching chains or straps of adequate load capacity to the Tie Down/Lifting D-Rings.

CAUTION

Overtightening of the chains or straps attached to the Tie Down/Lifting D-Rings may result in damage to work platform.

MAINTENANCE

⚠ WARNING ⚠

Never perform service while the platform is elevated without first blocking the elevating assembly.
DO NOT stand in the elevating assembly area while deploying or storing the brace.

BLOCKING THE ELEVATING ASSEMBLY

SCISSOR BRACE INSTALLATION

1. Park the work platform on a firm, level surface. Completely unload the platform before installing the Scissor Brace.
2. Verify that the Chassis and Platform Emergency Stop Switches are ON by twisting each button.
3. Turn and hold the Chassis Key Switch to CHASSIS. Push the Chassis Lift/Lower Switch to UP and elevate the platform approximately 2,1 m (7 ft.).
4. Rotate the Scissor Brace to a vertical position.
5. Carefully lower the platform until the end of the Scissor Arm Weldment rests on the Brace.

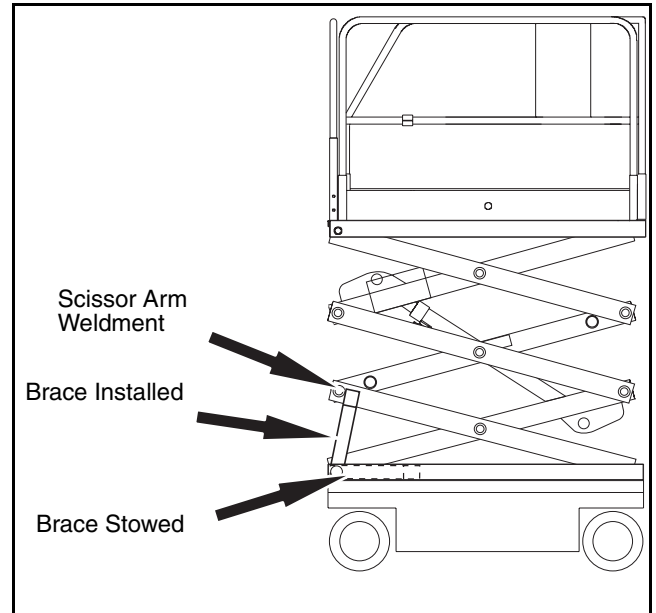

SCISSOR BRACE STOWAGE

1. While holding the Brace, slowly raise the platform using the Chassis Controls until the end of the Scissor Arm Weldment clears the Scissor Brace.
2. Rotate the Scissor Brace forward to rest on the Chassis.
3. Push the Chassis Lift/Lower Switch to LOWER and completely lower the platform.

BATTERY MAINTENANCE

⚠ WARNING ⚠

Hazard of explosive gas mixture. Keep sparks, flame, and smoking material away from batteries.

Always wear safety glasses when working near batteries.

Battery fluid is highly corrosive. Thoroughly rinse away any spilled fluid with clean water.

Always replace batteries with UpRight batteries or manufacturer approved replacements weighing 26,3 kg (58 lbs.) each.

- Check the battery fluid level daily, especially if the work platform is being used in a warm, dry climate.
- If electrolyte level is lower than 10 mm ($\frac{3}{8}$ in.) above the plates add distilled water only. DO NOT use tap water with high mineral content, as it will shorten battery life.
- Keep the terminals and tops of the batteries clean.
- Refer to the Service Manual to extend battery life and for complete service instructions.

BATTERY CHARGING

Charge the batteries at the end of each work shift or sooner if the batteries have been discharged.

Figure 8: Battery Charger

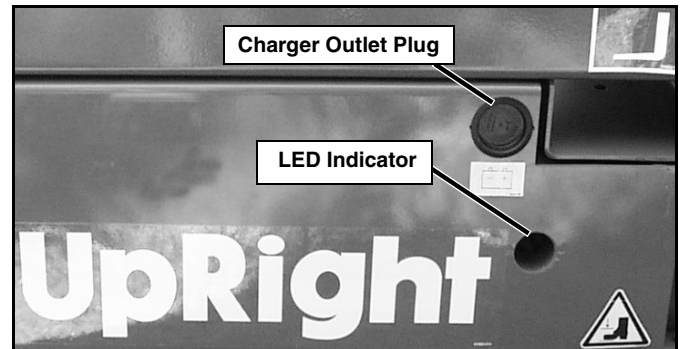

⚠ WARNING ⚠

Charge the batteries in a well ventilated area.

Do not charge the batteries when the work platform is near a source of sparks or flames.

Permanent damage to the batteries will result if the batteries are not immediately recharged after discharging.

Never leave the battery charger operating for more than two days.

Never disconnect the cables from the batteries when the charger is operating.

Keep the charger dry.

1. Check the battery fluid level. If the battery fluid level is lower than 10 mm ($\frac{3}{8}$ in.) above the plates add distilled water only.
2. Connect an appropriate extension cord to charger outlet plug in Left Module Door. Plug the extension cord into a properly grounded outlet of proper voltage and frequency.
3. The charger turns on automatically after a short delay. The LED charge indicator will illuminate. After completion of the charge cycle the LED will blink, indicating that the charger is in a continuing maintenance mode. DO NOT leave the charger plugged in for more than 48 hours, as permanent damage to the batteries may occur.

NOTE: The battery charger circuit must be used with a GFI (Ground Fault Interrupt) outlet.

NOTE: DO NOT operate the machine while the charger is plugged in.

INSPECTION AND MAINTENANCE SCHEDULE

The Complete Inspection consists of periodic visual and operational checks, along with periodic minor adjustments that assure proper performance. Daily inspection will prevent abnormal wear and prolong the life of all systems. The inspection and maintenance schedule should be performed at the specified intervals. Inspection and maintenance shall be performed by personnel who are trained and familiar with mechanical and electrical procedures.

! WARNING !

Before performing preventative maintenance, familiarize yourself with the operation of the machine. Always block the elevating assembly whenever it is necessary to perform maintenance while the platform is elevated.

The daily preventative maintenance checklist has been designed for machine service and maintenance. Please photocopy the Daily Preventative Maintenance Checklist and use the checklist when inspecting the machine.

DAILY PREVENTATIVE MAINTENANCE CHECKLIST

MAINTENANCE TABLE KEY

INTERVAL

- Y = Yes/Acceptable
- N = No/Not Acceptable
- R = Repaired/Acceptable

PREVENTATIVE MAINTENANCE REPORT

Date: _____

Owner: _____

Model No: _____

Serial No: _____

Serviced By: _____

COMPONENT	INSPECTION OR SERVICES	Y	N	R
Battery	Check electrolyte level.			
	Check battery cable condition.			
Chassis	Check hoses for pinch or rubbing points.			
	Check welds for cracks.			
Control Cable	Check the exterior of the cable for pinching, binding or wear.			
Controller	Check switch operation.			
Drive Motors	Check for operation and leaks.			
Elevating Assembly	Inspect for structural cracks.			
Emergency Lowering System	Operate the emergency lowering valve and check for serviceability.			
Entire Unit	Check for and repair collision damage.			

COMPONENT	INSPECTION OR SERVICES	Y	N	R
Hydraulic Fluid	Check fluid level.			
Hydraulic Pump	Check for hose fitting leaks.			
Hydraulic System	Check for leaks.			
Labels	Check for peeling, missing, or unreadable labels & replace.			
Platform Deck and Rails	Check welds for cracks.			
	Check condition of deck.			
Tires	Check for damage.			

SPECIFICATIONS

ITEM	MX19
Platform Size (Inside minimum) Standard w/Deck	0,57 m x 2,5 m (22.5 in. x 98.5 in.)
Maximum Platform Capacity Standard w/Deck Extension	227 kg (500 lbs.)
Maximum Number of Occupants Standard w/Deck Extension on Extension	2 People indoors/1 person outdoors 1 Person
Height Working Height Maximum Platform Height Maximum Drivable Height	7,8 m (25 ft. 6 in.) 5,8 m (19 ft.) 5,8 m (19 ft.)
Dimensions Weight Overall Width Overall Height (Lowered) Overall Length (Deck in)	1406 kg (3100 lbs.) 760 mm (30 in.) 2,02 m (79.5 in.) 1,60 m (63 in.)
Drive Speed Platform Lowered Platform Raised	3,7 km/h (2.3 mph) 1,0 km/h (0.62 mph)
Energy Source	24 V battery pack (4-220 A hour, 6 V batteries, min. wt. 26,3 kg [58 lbs.] each), 4 HP DC electric motor
System Voltage	24 V DC
Battery Charger	20 A, 240 V AC 50 Hz, Automatic
Hydraulic Tank Capacity	12,9 L (3.4 US gal.)
Maximum Hydraulic System Pressure	234 bar (3400 psi)
Hydraulic Fluid	
Normal above 32° F [0° C]	ISO #46
Low Temp. below 32° F [0° C]	ISO #32
below 0° F [-17° C]	ISO #15
Lift System	One Single Stage Lift Cylinder
Drive Control	Motor Control
Control System	Control Handle with Interlock Switch, Rotary Drive/Lift Switch, and Red Mushroom Emergency Stop Switch
Drive System	Dual Front Wheel Hydraulic Motors
Tires	30,5 cm (12 in.) diameter solid rubber, Non-marking
Turning Radius (inside)	150 mm (6 in.) Inside
Maximum Gradeability	25% (14°)
Wheel Base	1,23 m (48.5 in.)
Guardrails	1,10 m (43 in.)
Toeboard	150 mm (6 in.)
Noise Level	

*Specifications are subject to change without notice. Hot weather or heavy use may affect performance.

Refer to the Service Manual for complete parts and service information.

The MX19 meets or exceeds all applicable CE and GS machinery directive requirements.

Local Distributor:

Lokaler Vertriebshändler:

Distributeur local:

El Distribuidor local:

Il Distributore locale:

USA

TEL: +1 (559) 443 6600
FAX: +1 (559) 268 2433

UpRight
POWERED ACCESS

www.upright.com

Europe

TEL: +44 (0) 845 1550 058