

Operator Manual

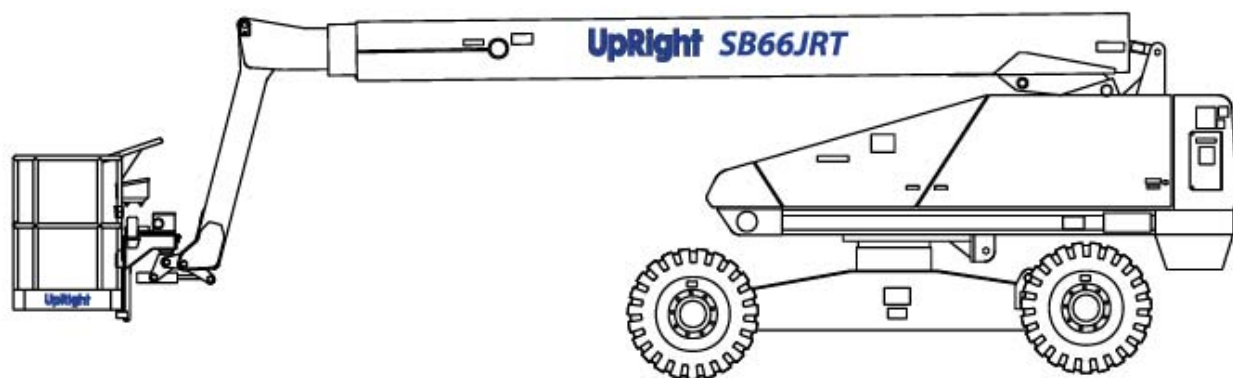

(EN) Manual part number 508372-002 for serial numbers 10032 to current.

Table of Contents

Declaration of Conformity	2	Transporting the Machine	13
Safety Rules	3	Preparing for Transportation	13
Introduction	4	By Crane	13
Component Identification	4	By Truck	13
Special Limitations	5	Maintenance	14
Platform Capacity	5	Hydraulic Fluid	14
Manual Force	5	Check Hydraulic Fluid	14
Platform Overload Sensing System	5	Engine	14
Beaufort Scale	5	Oil Level	14
Controls and Indicators	6	Battery Maintenance	14
Battery Disconnect Switch	6	Inspection and Maintenance Schedule	15
Lower Controls and Indicators	6	Daily Preventative Maintenance Checklist	16
Upper Controls and Indicators	6	Preventative Maintenance Report	16
Pre-Operation Safety Inspection	7	Decal Location	17
System Function Inspection	8	Specifications	20
Operation	9	Aerial Platform	20
Cold Weather Start-Up	9	Platform	20
Hydraulic System Cold Weather Warm-Up	9	Function Speed	20
Preparing for Operation	9	Drive System	20
Lower Controls	9	Tires	20
Upper Controls	10	Electrical System	20
Boom Operation	10	Hydraulic System	20
Driving and Steering	10	Engine	20
Drive Speeds	11	Fuel Tank Capacity	20
Motion Warning Alarm	11	Ambient Air Temperature Operating Range	20
AC Generator	11	Maximum Wind Speed	20
Air Line	11	Working Envelope	20
Driving Lights	12		
Platform Work Lights	12		
Emergency Lowering	12		
After Use Each Day	12		

EC DECLARATION OF CONFORMITY FOR MACHINERY

MACHINERY:

Powered Aerial Platform known as:

Type: SNORKEL TB66J (Upright SB66JRT)

Serial Number:

The machine specified above conforms to the following provisions:

Machinery directive 98/37/EC (using document **EC Community Legislation on Machinery** and taking guidance from EN280:2001 + Amendment A1:2004)

Council Directive 89/336/EEC on Electromagnetic Compatibility as amended by 93/68/EEC and 92/31/EC

Council Directive 73/23/EEC on Low Voltage Equipment Safety as amended by 93/68/EE

Council Directive 2000/14/EC on Noise Emission in the Environment by Equipment for use Outdoors

<i>As performed in accordance with EN 3744:1995</i>		
Measured sound power level	91 dB	Min
	100dB	Max
Guaranteed sound power level	100dB	

E. C. Type Examination Certificate No:



Note: Modification of the specified unit renders this declaration invalid

SAFETY RULES

⚠ Warning

All personnel shall carefully read, understand and follow all safety rules and operating instructions before operating or performing maintenance on any UpRight aerial work platform.

Electrocution Hazard

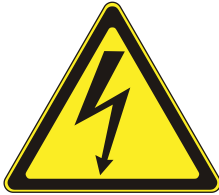

THIS MACHINE IS NOT INSULATED!

Tip Over Hazard



NEVER elevate the platform or drive the machine while elevated unless the machine is on a firm, level surface

Collision Hazard



NEVER position the platform without first checking for overhead obstructions or other hazards.

Fall Hazard



NEVER climb, stand, or sit on platform guardrails or midrail.

USE OF THE AERIAL WORK PLATFORM: This aerial work platform is intended to lift persons and his tools as well as the material used for the job. It is designed for repair and assembly jobs and assignments at overhead workplaces (ceilings, cranes, roof structures, buildings etc.). Uses or alterations to the aerial work platform must be approved by **UpRight**.

THIS AERIAL WORK PLATFORM IS NOT INSULATED! For this reason it is imperative to keep a safe distance from live parts of electrical equipment!

Exceeding the specified permissible maximum load **is prohibited!** See “Platform Capacity” on page 5 for details.

The use and operation of the aerial work platform as a lifting tool or a crane **is prohibited!**

NEVER exceed the manual force allowed for this machine. See “Manual Force” on page 5 for details.

DISTRIBUTE all platform loads evenly on the platform.

NEVER operate the machine without first surveying the work area for surface hazards such as holes, drop-offs, bumps, curbs, or debris; and avoiding them.

OPERATE machine only on surfaces capable of supporting wheel loads.

NEVER operate the machine when wind speeds exceed this machine’s wind rating. See “Beaufort Scale” on page 5 for details.

Do not operate the aerial platform in windy or gusty conditions. Do not add anything to the aerial platform that will increase the wind loading such as billboards, banners, flags, etc.

IN CASE OF EMERGENCY push EMERGENCY STOP switch to deactivate all powered functions.

IF ALARM SOUNDS while platform is elevated, STOP, carefully lower platform. Move machine to a firm, level surface.

Climbing up the railing of the platform, standing on or stepping from the platform onto buildings, steel or prefab concrete structures, etc., **is prohibited!**

Dismantling the entry gate or other railing components **is prohibited!** Always make certain that the entry gate is closed!

It is prohibited to keep the entry gate in an open position when the platform is raised!

To extend the height or the range by placing of ladders, scaffolds or similar devices on the platform **is prohibited!**

NEVER perform service on machine while platform is elevated without blocking elevating assembly.

INSPECT the machine thoroughly for cracked welds, loose or missing hardware, hydraulic leaks, loose wire connections, and damaged cables or hoses before using.

VERIFY that all labels are in place and legible before using.

NEVER use a machine that is damaged, not functioning properly, or has damaged or missing labels.

To bypass any safety equipment **is prohibited** and presents a danger for the persons on the aerial work platform and in its working range.

NEVER charge batteries near sparks or open flame. Charging batteries emit explosive hydrogen gas.

Modifications to the aerial work platform **are prohibited** or permissible only at the approval by **UpRight**.

AFTER USE, secure the work platform from unauthorized use by turning the keyswitch off and removing key.

The driving of MEWP’s on the public highway is subject to national traffic regulations.

Certain inherent risks remain in the operation of this machine despite utilizing proper design practices and safeguarding.

Harness attachment points are provided in the platform and the manufacturer recommends the usage of a fall restraint harness, especially where required by national safety regulations.

Care must be taken to ensure that the machines meets the requirements of stability during use, transportation, assembly, dismantling when out of service, testing, or foreseeable breakdowns.

In the event of an accident or breakdown see “Emergency Lowering” on page 12, do not operate the aerial platform if it is damaged or not functioning properly. Qualified maintenance personnel must correct the problem before putting the aerial platform back into service.

Introduction

Introduction

This manual covers the SB66JRT Aerial Work Platform.

This manual must be stored on the machine at all times.

Read, Understand and follow all safety rules and operating instructions before attempting to operate the machine.

When contacting UpRight for service or parts information, be sure to include the MODEL and SERIAL NUMBERS from the equipment nameplate. Should the nameplate be missing, the SERIAL NUMBER is also stamped at the top front of the chassis.

Component Identification

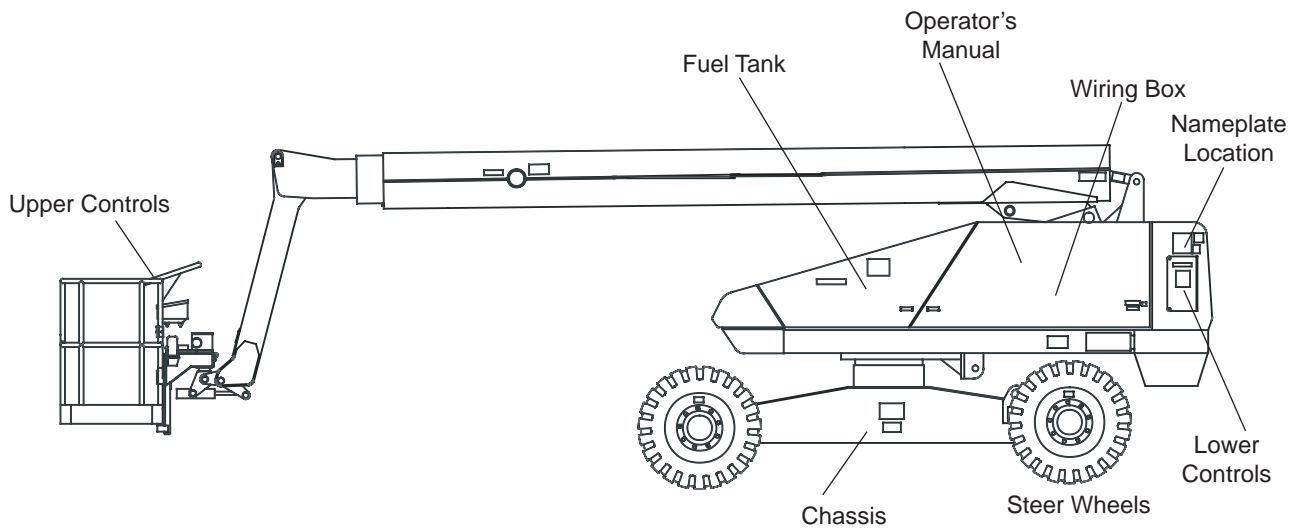

Right Side

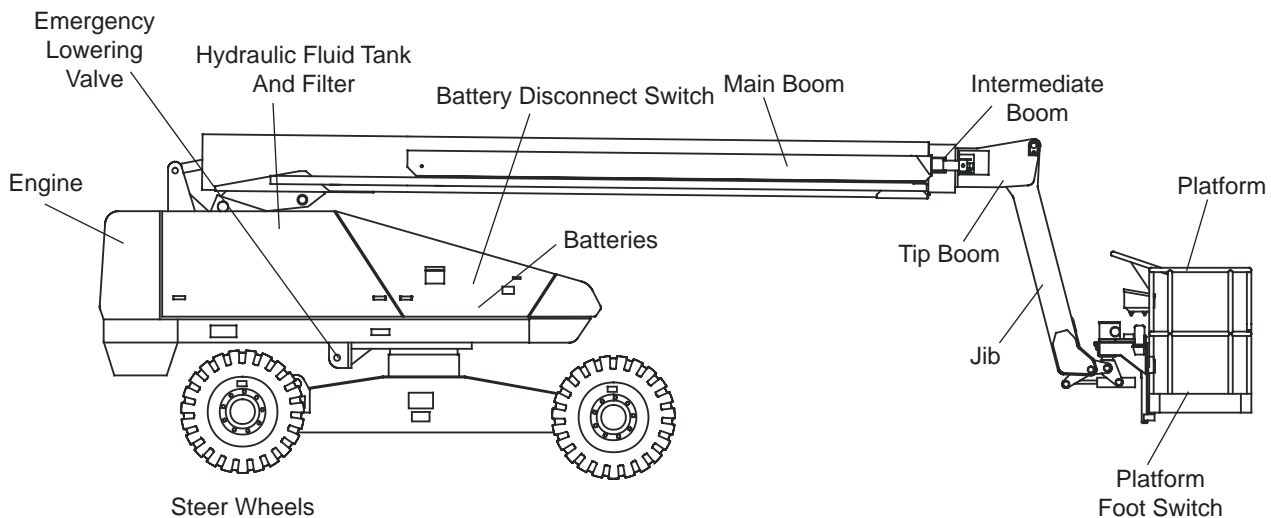

Left Side

Special Limitations

Travel with the platform raised is limited to creep speed range. Elevating the platform is limited to firm, level surfaces only.

⚠ Danger

The elevating function shall **ONLY** be used when the work platform is level and on a firm surface.

The work platform is **NOT** intended to be driven over uneven, rough, or soft terrain.

Platform Capacity

Two people and tools may occupy the platform. The maximum platform capacity for the aerial platform is stated in the "Specifications" on page 20.

⚠ Danger

DO NOT exceed the maximum platform capacity or the platform occupancy limits for this machine.

Manual Force

Manual force is the force applied by the occupants to objects such as walls or other structures outside the work platform.

The maximum allowable manual force is limited to 200N (45 lbs) of force per occupant, with a maximum of 400 N (90 lbs) for two occupants.

⚠ Danger

DO NOT exceed the maximum amount of manual force for this machine.

Platform Overload Sensing System

All functions are stopped from the upper and lower controls, when the platform overload limit is exceeded. The horn will sound intermittently and the platform overload light will blink until the excess load is removed from the platform. At that time, the machine functions are again operational.

If the platform becomes significantly overloaded, or if an upward force on the platform exceeds approximately 2225 N (500 lb), the system will enter into error mode, stopping all functions from the upper and lower controls. The horn will then sound constantly and the overload light will stay illuminated at the upper and lower controls.

The system will remain in error mode until the excess load is removed from the platform and the emergency stop button or start switch is cycled off and back on, resetting the system. At that time, the machine functions are operational.

⚠ Caution

The emergency power system is for emergency lowering and stowing only. The length of time the pump can be operated depends on the capacity of the battery. **Do not use this system for normal operation.**

If the platform overload sensing system is tripped while operating the machine or if the system is in error mode and can not be reset, the emergency power system may still be used for emergency machine operation.

⚠ Danger

The aerial platform can tip over if it becomes unstable. **Death or serious injury will result from a tip-over accident. Do not exceed the capacity values indicated on the platform rating placard.**

The overload sensing system is not active when the machine is being driven with the booms in the stowed position. This allows the machine to be driven without the system sensing an overload due to rough ground conditions.

To eliminate repeated tripping of the system during machine operation, there is a five second delay in machine functions following:

- starting the engine.
- placing the drive/boom selector switch in the boom position when the main boom is below horizontal and fully retracted.
- removing excess load from the platform.

Beaufort Scale

Never operate the machine when wind speeds exceed 12.5 m/s (28mph) [Beaufort scale 6]. Refer to Figure 1.

BEAUFORT RATING	WIND SPEED				GROUND CONDITIONS
	m/s	km/h	ft/s	mph	
3	3,4~5,4	12,25~19,4	11.5~17.75	7.5~12.0	Papers and thin branches move, flags wave.
4	5,4~8,0	19,4~28,8	17.75~26.25	12.0~18	Dust is raised, paper whirls up, and small branches sway.
5	8,0~10,8	28,8~38,9	26.25~35.5	18~24.25	Shrubs with leaves start swaying. Wave crests are apparent in ponds or swamps.
6	10,8~13,9	38,9~50,0	35.5~45.5	24.5~31	Tree branches move. Power lines whistle. It is difficult to open an umbrella.
7	13,9~17,2	50,0~61,9	45.5~56.5	31.~38.5	Whole trees sway. It is difficult to walk against the wind.

Figure 1 – Beaufort Scale

Controls and Indicators

The operator shall know the location of each control and indicator and have a thorough knowledge of the function and operation of each before attempting to operate the machine.

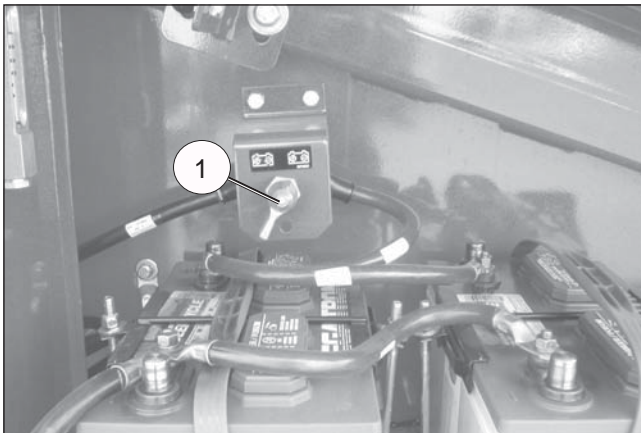

Figure 2 – Battery Disconnect Switch

- 1. Battery Disconnect Switch

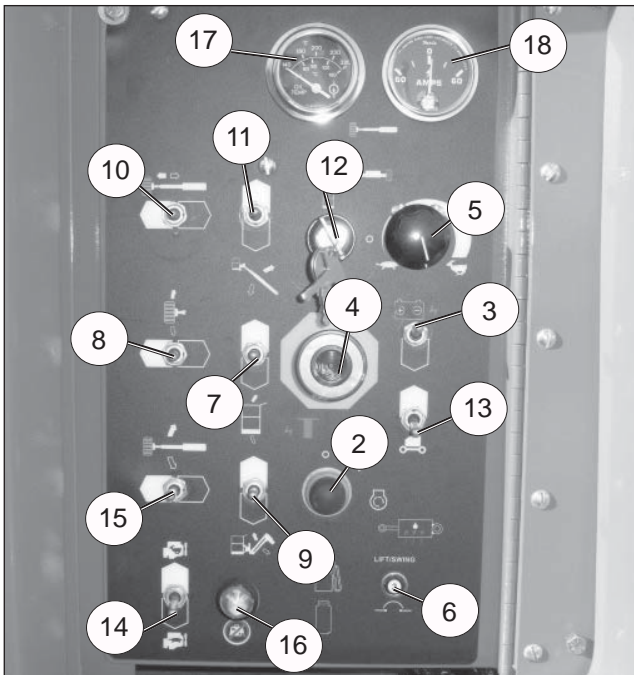

Figure 3 – Lower Controls and Indicators

- 2. Start button
- 3. Engine/emergency power switch
- 4. Emergency stop button
- 5. Boom speed knob
- 6. Circuit breaker reset button
- 7. Platform level switch
- 8. Platform rotate switch
- 9. Jib articulation switch
- 10. Boom extend/ retract switch
- 11. Boom elevation switch
- 12. Control selector switch

- 13. Ground operation switch
- 14. Engine throttle switch
- 15. Boom rotate switch
- 16. Platform overload light
- 17. Engine temperature gauge
- 18. Ammeter

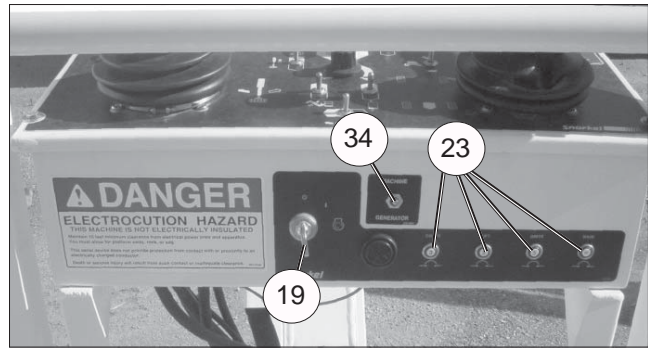
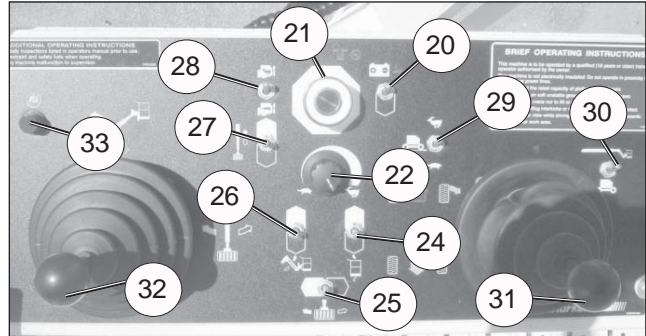

Figure 4 – Upper Controls and Indicators

- 19. Start switch
- 20. Engine/emergency power switch
- 21. Emergency stop button
- 22. Boom speed knob
- 23. Circuit breaker reset buttons
- 24. Platform level switch
- 25. Platform rotate switch
- 26. Jib articulation switch
- 27. Boom extend/ retract switch
- 28. Engine throttle switch
- 29. Drive range switch
- 30. Drive/ boom selector switch
- 31. Drive joystick
- 32. Boom joystick
- 33. Platform overload light
- 34. Machine/generator switch

Pre-Operation Safety Inspection

Note

Carefully read, understand and follow all safety rules, operating instructions, labels and National Safety Instructions/Requirements. Perform the following steps each day before use.

1. Open the turntable covers and inspect for damage, fluid leaks or missing parts.
2. Check the level of the hydraulic fluid with the platform fully lowered. The fluid level must be between the full and add marks as viewed on the sight glass. Add recommended hydraulic fluid if necessary. See “Specifications” on page 20.
3. Check that the fluid level in the batteries is correct. See “Battery Maintenance” on page 14.
4. Check that all guardrails are in place and all fasteners are properly tightened.
5. Inspect the machine thoroughly for cracked welds and structural damage, loose or missing hardware, hydraulic leaks, damaged control cable and loose wire connections.

System Function Inspection

Refer to “Controls and Indicators” on page 6 for the locations of various controls and indicators.

Warning

STAND CLEAR of the work platform while performing the following checks.

Before operating the machine, survey the work area for surface hazards such as holes, drop-offs, bumps and debris.

Check in ALL directions, including above the work platform, for obstructions and electrical conductors.

1. Move the machine, if necessary, to an unobstructed area to allow for full elevation.
2. Pull the Lower Control Emergency Stop Switch to the ON position.
3. Pull the Upper Control Emergency Stop Switch to the ON position.
4. Visually inspect the elevating assembly, lift cylinder, cables, and hoses for cracked welds and structural damage, loose hardware, hydraulic leaks, loose wire connections, and erratic operation. Check for missing or loose parts.
5. Test each machine function (Lift, Slew, Telescope) from the lower control station by holding the ground operation switch up while operating the control toggle switches (ref: Figure 3 on page 6).
6. Test the engine/emergency power switch for proper operation.
7. Push the Lower Control Emergency Stop Button to check for proper operation. All machine functions should be disabled. Pull the Lower Control Emergency Stop Button outward to resume.
8. Enter the platform and close the gate.
9. Check that the route is clear of obstacles (persons, obstructions, debris), is level, and is capable of supporting the wheel loads.
10. Test each machine function (Drive, Lift, Slew, Telescope, Platform Rotate, Platform Level) from the upper control station by stepping on the platform foot switch and operating the function controls (ref: Figure 4 on page 6).
11. Push the Upper Control Emergency Stop Button to check for proper operation. All machine functions should be disabled. Pull the Upper Control Emergency Stop Button outward to resume.

Operation

The aerial platform may be operated from either the lower or upper controls.

Danger

The aerial platform is not electrically insulated. Death or serious injury will result from contact with, or inadequate clearance from, an energized conductor. Do not go closer than the minimum safe approach distance as defined by national safety regulations.

Pinch points may exist between moving components. Death or serious injury will result from becoming trapped between components, buildings, structures or other obstacles. Make sure there is sufficient clearance around the machine before moving the chassis, booms, or platform. Allow sufficient room and time to stop movement to avoid contact with structures or other hazards.

The aerial platform can tip over if it becomes unstable. Death or serious injury will result from a tip-over accident. Operate the aerial platform on a firm, flat, level surface. Avoid travel speeds and/or rough terrain that could cause sudden changes in platform position. Do not drive or position the aerial platform for elevated use near any drop-off, hole, slope, soft or uneven ground, or other tip-over hazard.

The platform rated work load is the total weight of the personnel and equipment that may be lifted in the platform. The work loads are stated on the platform rating placard mounted at the rear of the platform.

Danger

The aerial platform can tip over if it becomes unstable. Death or serious injury will result from a tip-over accident. Do not exceed the capacity values indicated on the platform rating placard.

Capacity values indicate the rated lifting capacity and do not indicate aerial platform stability.

The operator bears ultimate responsibility for ensuring that the aerial platform is properly set up for the particular conditions encountered.

Cold Weather Start-Up

If the ambient temperature is 0°C (32°F) or below, the engine and hydraulic system oil may need to be warmed before operation. Do not operate the engine at more than a fast idle until the engine and hydraulic oil has had a chance to warm. The engine may be equipped with an optional cold weather start kit.

Cold, thick hydraulic oil does not flow well and may cause delay in response to control movement and improper voltage output of the AC generator. Cold oil may also cause cavitation and pump damage. The hydraulic system may be equipped with an optional cold weather warm-up kit.

At the lower controls, hold the manifold heater switch on for about a minute before turning the master switch to start the engine. A glow plug in the manifold preheats the air to help start the engine. Continue to hold the switch while starting the engine. Do not release the switch until the engine starts.

If the engine does not start within 20 seconds, continue to hold the manifold heater switch and turn the master switch off. Wait for one minute before trying to start the engine again.

Hydraulic System Cold Weather Warm-Up

The hydraulic oil may be warmed by bottoming out the boom extension cylinder. Raise the main boom so it is horizontal and operate the boom retract function while the machine is stowed. With the cylinder bottomed out the oil flow will produce heat to warm the hydraulic oil.

Caution

Not all hydraulic fluid is suitable to use in the hydraulic system. Some have poor lubricating characteristics and can increase component wear. Only use hydraulic fluid as recommended.

Use cold weather hydraulic oil as recommended in the machine General Specifications in temperatures of -12°C (10°F) or below.

Preparing for Operation

Use the following procedure to prepare the aerial platform for operation.

1. Perform a prestart inspection as described in the "Daily Preventative Maintenance Checklist" on page 16.
2. Place the battery disconnect switch in the on position.
3. Close and latch the doors.
4. Before painting or sandblasting make sure the sandblast protection kit and the platform control cover are properly installed. These options, when used properly will protect the control placards and cylinder rods from paint overspray and abrasion while sandblasting.

Lower Controls

The lower controls override the upper controls. This means that the lower controls can always be used to operate the platform regardless of the position of the upper control emergency stop button.

Boom, turntable, and platform functions may be operated from the lower controls. The lower controls may be used for initial set up of the aerial platform, and for testing and inspection.

Use the following procedure to operate boom, turntable, or platform functions using the lower controls (ref: Figure 3 on page 6).

Operation

1. Pull the emergency stop button outward. Insert the key in the control selector and turn the switch to the lower control position.
 2. Press the start button until the engine starts, then release. The engine will not start if the control selector switch is left in the lower control position for 30 seconds or longer before starting the engine. The control selector switch must be turned back to off before the engine will start.
 3. Let the engine warm to operating temperature.
 4. Turn the boom speed knob to slow.
 5. Hold the ground operation switch up while operating the control toggle switches.
 6. Hold the appropriate toggle switch in the desired direction.
 7. Release the function toggle switch to stop movement.
 8. Place the ground operation switch in the off position when no functions are being operated.
2. Step down on the platform foot switch. This switch must be held down to operate the upper controls.
 3. Hold the appropriate control in the desired direction. Always look in the direction of movement.
 4. Gradually turn the boom speed knob to control the boom extend, jib and platform rotate function speed.
 5. Releasing the control to its neutral position, or releasing the foot switch will stop movement.

Upper Controls

The upper controls may be used for driving the aerial platform and positioning the booms and platform while on the job.

Use the following procedure to operate machine functions using the upper controls.

1. At the lower controls, pull the emergency stop button outward. Insert the key in the control selector and turn the switch to the upper control position.
2. Enter the platform and securely close the gate.
3. Attach the fall restraint lanyard to one of the anchor points.
4. Pull the emergency stop outward.
5. Turn the anti-restart master switch to on and pause a few seconds while the alarm sounds to alert others that the machine is about to start. Turn the switch to start, then release it to on. The engine will not start if the switch is left in the on position for 30 seconds or longer before turning it to start. The switch must be turned back to off before the engine will start.
6. Let the engine warm to operating temperature.

Boom Operation

Use the following procedure to operate the turntable, boom, or platform functions.

1. Turn the boom speed knob to slow.

Driving and Steering

Danger

The aerial platform can tip over if it becomes unstable. Death or serious injury will result from a tip-over accident. Do not drive an elevated aerial platform on soft, uneven, or sloping surfaces. Do not drive the machine on grades that exceed 25 percent.

For operation on grades up to 30 percent, it is recommended that the main boom be near horizontal and the jib on the aerial platform elevated just enough to provide adequate ground clearance. A 30 percent grade is a 0.91 m (36") vertical rise in 3.05 m (10") horizontal length.

Avoid driving with the platform over the front (steer) end of the chassis. In this position the machine is difficult to control because:

- drive and steer control movements and their resulting machine movements are reversed.
- when driving fast, sudden turns or stops produce more severe reactions to platform occupants.
- more turning space is required to prevent the platform from colliding with obstacles several feet beyond the path of the tires.

Warning

Death or serious injury can result from improperly driving or steering the aerial platform. Read and understand the information in this manual and on the placards and decals on the machine before operating the aerial platform on the job.

The blue and yellow arrows on the chassis indicate the direction the chassis will move when the drive or steer control is moved toward the corresponding color.

When the machine is in the stowed position, with the booms centered between the rear wheels, the direction of drive and steer control movement corresponds with the direction of chassis movement.

When the turntable is rotated from the stowed position, with the booms to either side of or in front of the chassis, the direction of control movement does not correspond with the direction of chassis movement.

To avoid confusion, always drive to the work area or move between work areas with the turntable and booms in the stowed position. After arriving at the work area, the booms may be positioned to the side or the front of the chassis for final positioning. Always look in the direction of movement as indicated by the directional arrows on the chassis.

Use the following procedure to operate the drive and steer functions.

1. Determine the desired drive range for the specific driving conditions.
 - Use high range when traveling across firm, flat, level surfaces. High range can only be activated when the booms are stowed. High range is for high speed, low torque operation.
 - Use low range for driving on loading ramps or other steep grades and when safety considerations demand slow deliberate machine movement. Low range is for low speed, high torque operation.
2. Place the drive/boom selector switch in the drive position.
3. Step down on the platform foot switch.
4. Push the drive joystick forward to move the chassis forward, the direction of the blue arrow. Pull the joystick backward to move the chassis backward, the direction of the yellow arrow. The drive speed is proportional to the joystick position.
5. To stop drive motion, return the joystick to neutral.
6. Push the drive joystick to the right to steer to the right, the direction of the yellow arrow. Push the joystick to the left to steer to the left, the direction of the blue arrow.

Note

The steering wheels are not self-centering. Set the steering wheels straight ahead after completing a turn.

7. After driving to the desired location, release the foot switch, or push the emergency stop button to apply the parking brakes.

Drive Speeds

The drive speed is proportional to the joystick position. The farther the joystick is moved, the faster the travel speed.

Always slow down and shift the drive system to low range before traveling over rough terrain or any sloped surface.

Drive speed ranges are interlocked through a limit switch that senses the main boom position. When the boom is elevated, only the slowest drive speed will work regardless of the drive range switch position.

Warning

The potential for an accident increases when safety devices do not function properly. Death or serious injury can result from such accidents. Do not alter, disable or override any safety device.

Do not use the aerial platform if it drives faster than 0.96 km/h (0.6 miles per hour) [7.9 m (26 feet) in 30 seconds] when the booms are elevated from the stowed position.

Motion Warning Alarm

The optional motion warning alarm sounds loud intermittent beeps when the drive joystick is in the forward or reverse position.

AC Generator

The optional generator supplies power to the electrical outlet only when the engine is running and the machine is stationary. The machine functions will not operate when the machine/generator selector switch is in the generator position.

Caution

Cold hydraulic oil does not flow well and may produce improper generator output voltage. Improper outlet voltage can damage some electrical power tools and equipment. Warm the hydraulic oil before operating the generator.

Do not operate the generator unless the hydraulic oil temperature is at least 38°C (100°F). Refer to Cold Weather Start-Up for a hydraulic oil warm-up procedure.

Start the engine and place the machine/generator selector switch in the generator position (ref: Figure 4 on page 6).

The engine will run at high idle while the generator is operating. The generator will continue to operate as long as the engine is running and the switch is in the generator position.

Air Line

The optional air line may be used to conduct air for tool operation at the platform. The input connector is at the rear of the chassis and the output connector is at the platform on the rotator guard. The maximum working pressure of the line is 1,723 kPa (250 psi).

The air line may be used to conduct fluids such as water or antifreeze. Contact your local distributor or UpRight for compatibility information before using the air line to conduct other fluids.

Caution

Fluid in the air line can damage some air tools or freeze and damage the line. Drain and blow out the air line after using it to conduct fluids.

Operation

Use the following procedure to drain the air line.

1. Close the input connector on the chassis.
2. Open the output connector at the platform.
3. Raise the boom slightly above horizontal.
4. Open the input connector on the chassis.
5. Allow the fluid to drain from the line.
6. Lower the boom and close both connections.

Driving Lights

The optional driving lights are for use in dimly lit areas and are not intended for driving on public roadways. There are two headlights at the front of the chassis and two blinking taillights at the rear of the chassis. The lights are operational when the battery disconnect switch and the master switch are turned on.

Note

Working with the driving or platform work lights on, while the engine is off, can discharge the batteries enough that the engine will not start or the emergency power system will not operate. If the engine cannot be left running while the lights are on, start and run the engine for at least 15 minutes each hour.

Platform Work Lights

The optional platform work lights are located on the top rail of the platform. The direction a light points can be adjusted by using two 1/2" wrenches to loosen the clamp below the light.

The lights are operational when the upper controls emergency stop button is pulled up and the anti-restart master switch is turned on. The engine speed increases to high idle when the platform work lights are turned on.

Emergency Lowering

Warning

If the platform should fail to lower, NEVER climb down the elevating assembly.

Stand clear of the elevating assembly while operating the Emergency Lowering Valve Knob.

Ask a person on the ground to open the Emergency Lowering Valve to lower the platform. The Emergency Lowering Valve is located on the base of the lift cylinder.

1. Slowly turn the knob to open the bleed down valve. Control the rate of descent by turning the knob.
2. To close, turn the knob.

Note

The platform will not elevate if the Emergency Lowering Valve is open.

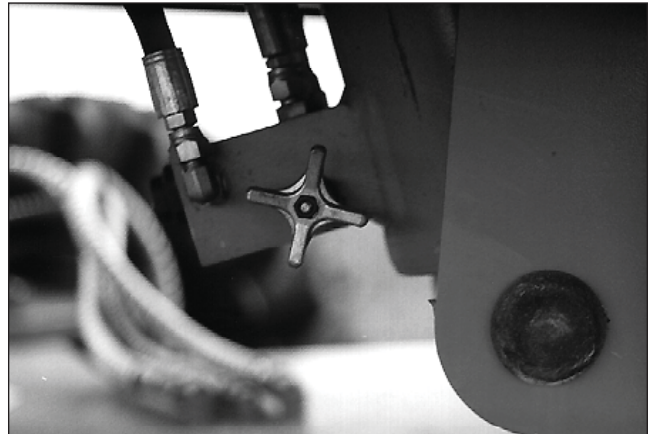

Figure 5 – Emergency Lowering Valve

After Use Each Day

1. Ensure that the platform is fully lowered.
2. Park the machine on a firm level surface, preferably under cover, secure against vandals, children and unauthorized operation.
3. Turn the Chassis Key Switch to OFF and remove the key to prevent unauthorized operation.

Transporting the Machine Preparing for Transportation

Use the following procedure to prepare the aerial platform for transportation.

1. Remove any unnecessary tools, materials, or other loose objects from the platform.
2. Close and latch all cowling doors.

By Crane

Secure the straps to chassis lifting/lugs only.

Know the approximate location of the center of gravity before lifting the machine off the ground. Refer to Figure 6.

▲Danger

Lifting by Crane is for transport purposes only.

See Specifications for weight of machine and be certain that the crane is of adequate capacity to lift the machine.

By Truck

1. Maneuver the machine into transport position and chock wheels.
2. Place a wood block under the tip end of the jib foot. Lower the platform so the foot rests on the wood block.

▲Caution

Ratchets, winches, and come-alongs can produce enough force to damage machine components. Do not over tighten the straps or chains when securing the aerial platform to the transport vehicle.

3. Use a nylon strap to securely fasten the platform against the wood block. Thread the strap over the toeboard. Refer to Figure 7.



Figure 7 – Platform

4. Secure the machine to the transport vehicle with chains or straps of adequate load capacity attached to the chassis lifting/tie down points.

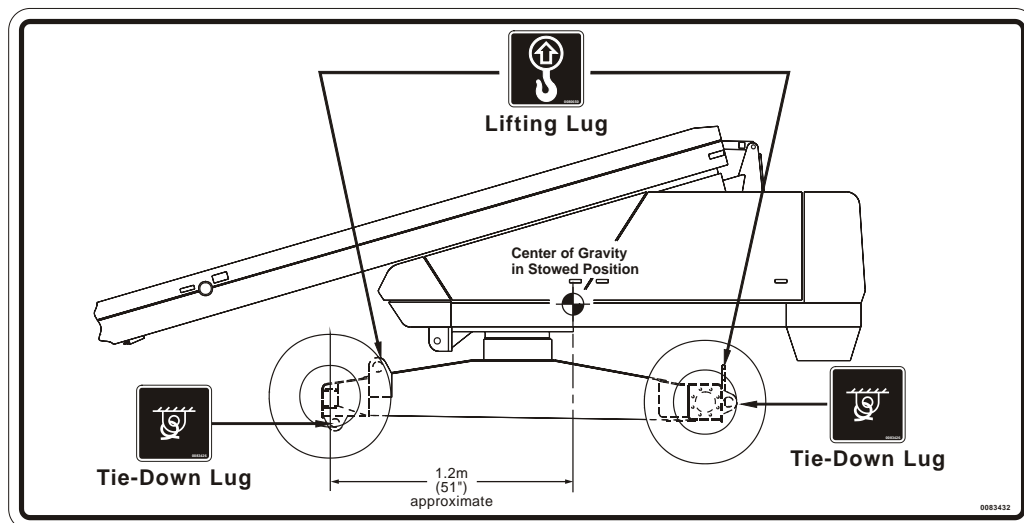

Figure 6 – Center of Gravity

Maintenance

⚠ Warning

Never perform service while the platform is elevated.

Hydraulic Fluid

The hydraulic fluid reservoir is located in the chassis door. Refer to Figure 8.



Figure 8 – Hydraulic Fluid Reservoir

Note

Never add fluid if the platform is elevated.

Check Hydraulic Fluid

1. Make sure that the platform is fully lowered.
2. Open the left front cowling door.
3. Check the fluid level on the gauge on the end of the reservoir.
4. Add the appropriate fluid to bring the level to the FULL mark. See "Specifications" on page 20.

Engine

Open the engine compartment doors on both sides of the machine and visually inspect the engine and its components with the engine off.

Oil Level

Check the engine oil level before starting the engine so the oil has drained to the pan. The proper oil level is between the add and full marks on the dipstick.

The distance between the top and bottom dipstick marks corresponds to about 1 l (1 quart US). Add oil, if necessary, before starting the engine.

Battery Maintenance

⚠ Warning

Hazard of explosive gas mixture. Keep sparks, flame, and smoking material away from batteries.

Always wear safety glasses when working near batteries.

Battery fluid is highly corrosive. Thoroughly rinse away any spilled fluid with clean water.

Always replace batteries with Snorkel batteries or manufacturer approved replacements weighing 26,3 kg (58 lbs) each.

- Check the battery fluid level daily, especially if the machine is being used in a warm, dry climate.

If electrolyte level is lower than 10 mm (3/8") above the plates add distilled water only. DO NOT use tap water with high mineral content, as it will shorten battery life.

- Keep the terminals and tops of the batteries clean.
- Refer to the Service Manual to extend battery life and for complete service instructions.

Inspection and Maintenance Schedule

The Complete Inspection consists of periodic visual and operational checks, along with periodic minor adjustments that assure proper performance. Daily inspection will prevent abnormal wear and prolong the life of all systems. The inspection and maintenance schedule should be performed at the specified intervals and after prolonged periods of storage before returning the machine to service. Inspection and maintenance shall be performed by personnel who are trained and familiar with mechanical and electrical procedures.

Warning

Before performing preventative maintenance, familiarize yourself with the operation of the machine. Always block the elevating assembly whenever it is necessary to perform maintenance while the platform is elevated.

The daily preventative maintenance checklist has been designed for machine service and maintenance. Please photocopy the Daily Preventative Maintenance Checklist and use the checklist when inspecting the machine.

Daily Preventative Maintenance Checklist

Daily Preventative Maintenance Checklist

Preventative Maintenance Report

Date: _____ Serial No: _____

Owner: _____ Serviced By: _____

Model No: _____

ITEM	INSPECTION OR SERVICES	Y	N	R
Operator's Manual	In place, all pages readable and intact			
Engine				
Oil level	Between full and add marks			
Coolant	Air intake and fan free of obstructions, belt in good condition			
Radiator	Cap tight, good condition and clean			
Fuel tank and line	Tank full, cap in place and tight/ no leaks			
Air filter	Clear indicator			
Charging system	Proper operation			
Cold weather start kit	No damage or deformation			
Electrical System				
Emergency power battery	Condition and charged for proper operation			
Battery fluid level and terminals	Proper level/clean, connectors tight			
Cables and wiring harness	No wear or physical damage			
Hydraulic System				
Fluid level	Between full and add marks			
Fluid filter	Verify operation in the green zone			
Hose, tubes and fittings	No leaks			
Cold weather warm-up kit	Proper operation			
Foam Filled Tires and Wheels	Good condition			
Lower Control Station				
Operating controls	Proper operation			
Emergency stop and emergency power	Shuts off lower controls/proper operation			
Emergency Lowering	Proper operation			
Level Sensor	Sounds tilt alarm			
Flashing Light	Proper operation			
Sandblast Protection Kit	In place and proper operation			
Bumpguard	In place, no damage or deformation			
Structures				
Weldments	Welds intact, no damage or deformation			
Slide pads	In place, no damage or deformation			
Fasteners	In place and tight.			
Wire ropes	No deformation or broken strands			
Upper Control Station				
Guardrail system and lanyard anchors	Welds intact, no damage or deformation			
Operating controls	Proper operation			
Emergency stop and emergency power	Shuts off upper controls/proper operation			
Horn	Sounds when activated.			
Electrical power outlet	Proper operation of outlet			
Drive motion alarm	Sounds when aerial platform moves			
Driving and work lights	Proper operation			
Platform control cover	In place and proper operation			
Placards and Decals	In place and readable			

Maintenance Table Key: Y = Yes/Acceptable, N = No/Not Accetable, R = Repaired/Acceptable

Decal Location

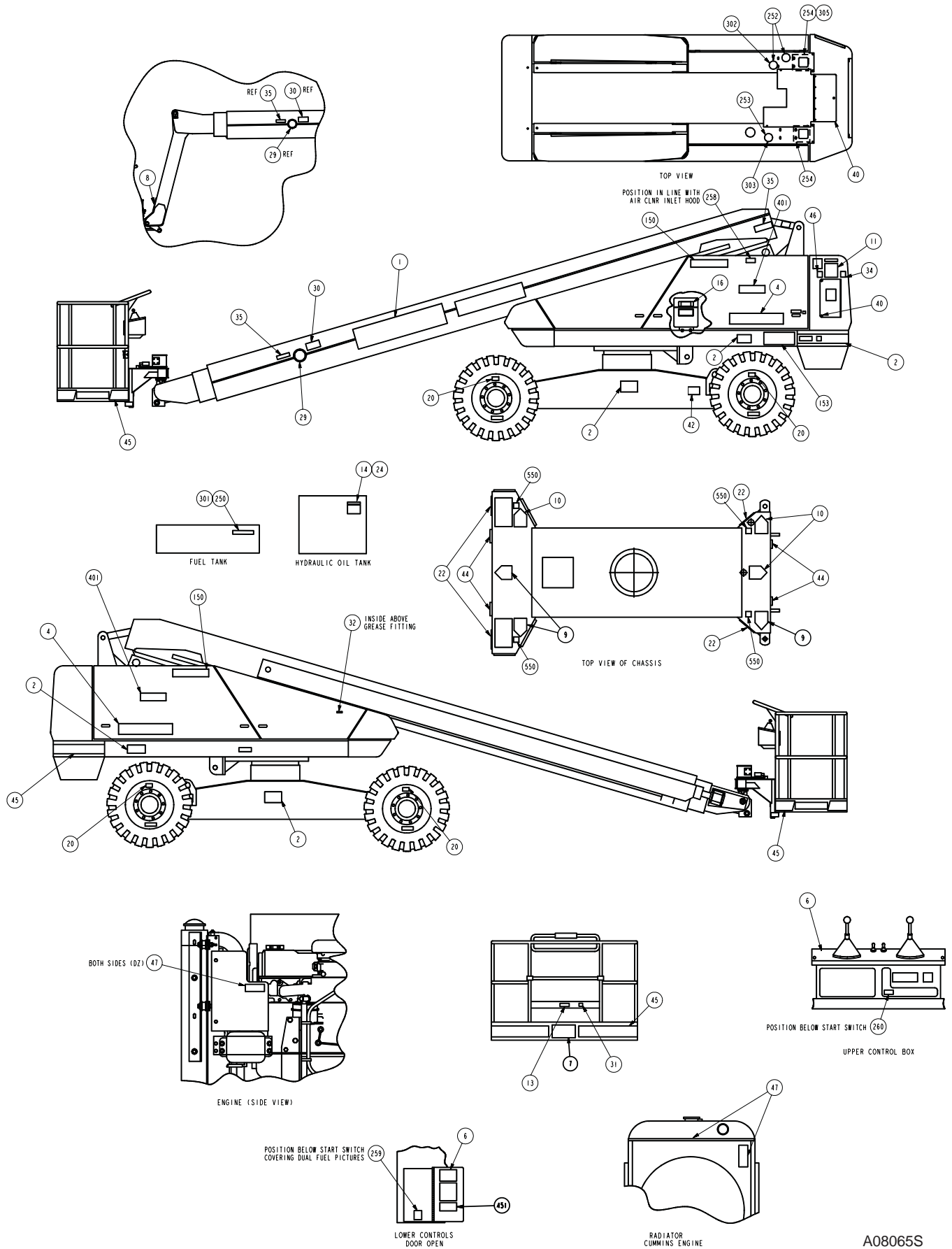

Decal Location

ITEM	PART NO.	QTY	DESCRIPTION
1	508229-001	1	DECAL, UPRIGHT BRAND LOGO
2	0162336E	5	DECAL, DANGER ELECTRICAL HAZARD – ENGLISH
	0162336F	5	DECAL, DANGER ELECTRICAL HAZARD – FRENCH
	0162336P	5	DECAL, DANGER ELECTRICAL HAZARD – SPANISH
	0162336W	5	DECAL, DANGER ELECTRICAL HAZARD – SWEDISH
	0162336D	5	DECAL, DANGER ELECTRICAL HAZARD – DUTCH
	0162336G	5	DECAL, DANGER ELECTRICAL HAZARD – GERMAN
4	508234-003	2	DECAL, UPRIGHT BRAND LOGO
6	0162328E	1	DECAL, BRIEF OPERATING INSTRUCTIONS – ENGLISH
	0162329E	1	DECAL, ADDITIONAL OPERATING INSTRUCTIONS – ENGLISH
	0162328F	1	DECAL, BRIEF OPERATING INSTRUCTIONS – FRENCH
	0162329F	1	DECAL, ADDITIONAL OPERATING INSTRUCTIONS – FRENCH
	0162328P	1	DECAL, BRIEF OPERATING INSTRUCTIONS – SPANISH
	0162329P	1	DECAL, ADDITIONAL OPERATING INSTRUCTIONS – SPANISH
	0162328W	1	DECAL, BRIEF OPERATING INSTRUCTIONS – SWEDISH
	0162329W	1	DECAL, ADDITIONAL OPERATING INSTRUCTIONS – SWEDISH
	0162328D	1	DECAL, BRIEF OPERATING INSTRUCTIONS – DUTCH
	0162329D	1	DECAL, ADDITIONAL OPERATING INSTRUCTIONS – DUTCH
	0162328G	1	DECAL, BRIEF OPERATING INSTRUCTIONS – GERMAN
	0162329G	1	DECAL, ADDITIONAL OPERATING INSTRUCTIONS – GERMAN
7		1	PLACARD, PLATFORM CAPACITY (CONSULT FACTORY)
8	0162336E	1	DECAL, DANGER ELECTRICAL HAZARD – ENGLISH
	0162366	1	DECAL, DANGER ELECTRICAL HAZARD – ENGLISH

ITEM	PART NO.	QTY	DESCRIPTION
	0162336F	1	DECAL, DANGER ELECTRICAL HAZARD – FRENCH
	0162366	1	DECAL, DANGER ELECTRICAL HAZARD – FRENCH
	0162336P	1	DECAL, DANGER ELECTRICAL HAZARD – SPANISH
	0162366	1	DECAL, DANGER ELECTRICAL HAZARD – SPANISH
	0162336W	1	DECAL, DANGER ELECTRICAL HAZARD – SWEDISH
	0162366	1	DECAL, DANGER ELECTRICAL HAZARD – SWEDISH
	0162336D	1	DECAL, DANGER ELECTRICAL HAZARD – DUTCH
	0162366	1	DECAL, DANGER ELECTRICAL HAZARD – DUTCH
	0162336G	1	DECAL, DANGER ELECTRICAL HAZARD – GERMAN
	0162366	1	DECAL, DANGER ELECTRICAL HAZARD – GERMAN
9	0070540	3	DECAL, YELLOW ARROW
10	0070541	3	DECAL, BLUE ARROW
11	0070901	1	PLACARD, CAUTION SERIAL NUMBER
13	0071425	1	PLACARD, PLATFORM IDENTIFICATION
14	0071927	1	DECAL, HYDRAULIC OIL
16	562386	1	RECORD BOX
20	0072277	4	PLACARD, LUG NUT TORQUE
22	0080650	4	DECAL, LIFT
24	7030003	1	DECAL, LUBE RECOMMENDATIONS
29	9980013	2	PLUG 3-1/2 INCH DIAMETER
30	0190989E	1	DECAL, DANGER DO NOT REACH
31	0150448	1	DECAL, ATTACH FALL RESTRAINT – ENGLISH
	0150448F	1	DECAL, ATTACH FALL RESTRAINT – FRENCH
	0150448P	1	DECAL, ATTACH FALL RESTRAINT – SPANISH
	0150448W	1	DECAL, ATTACH FALL RESTRAINT – SWEDISH
	0150448D	1	DECAL, ATTACH FALL RESTRAINT – DUTCH
	0150448G	1	DECAL, ATTACH FALL RESTRAINT – GERMAN

ITEM	PART NO.	QTY	DESCRIPTION
32	0073492	1	DECAL, ROTATE WHILE GREASING – ENGLISH
	0073492F	1	DECAL, ROTATE WHILE GREASING – FRENCH
	0073492P	1	DECAL, ROTATE WHILE GREASING – SPANISH
	0073492W	1	DECAL, ROTATE WHILE GREASING – SWEDISH
	0073492D	1	DECAL, ROTATE WHILE GREASING – DUTCH
	0073492G	1	DECAL, ROTATE WHILE GREASING – GERMAN
34	0074372	1	PLACARD, ENGINE RPM – ENGLISH
	0074372F	1	PLACARD, ENGINE RPM – FRENCH
	0074372P	1	PLACARD, ENGINE RPM – SPANISH
	0074372W	1	PLACARD, ENGINE RPM – SWEDISH
	0074372D	1	PLACARD, ENGINE RPM – DUTCH
	0074372G	1	PLACARD, ENGINE RPM – GERMAN
35	0073667	2	DECAL, INSPECT WIRE ROPES – ENGLISH
	0073667F	2	DECAL, INSPECT WIRE ROPES – FRENCH
	0073667P	2	DECAL, INSPECT WIRE ROPES – SPANISH
	0073667W	2	DECAL, INSPECT WIRE ROPES – SWEDISH
	0073667D	2	DECAL, INSPECT WIRE ROPES – DUTCH
	0073667G	2	DECAL, INSPECT WIRE ROPES – GERMAN
40	5569012	4	RUBBER BUMPER
42	0162311	1	DECAL, CE LOGO
44	0083426	4	DECAL, TIE DOWN SYMBOL
45	7030001	25 FT	WARNING STRIPE
46	0182077E	1	DECAL, CE NOISE LEVEL
47	0151410E	1	DECAL, DANGER ROTATING PARTS – ENGLISH
	0151410F	1	DECAL, DANGER ROTATING PARTS – FRENCH
	0151410P	1	DECAL, DANGER ROTATING PARTS – SPANISH
	0151410W	1	DECAL, DANGER ROTATING PARTS – SWEDISH
	0151410D	1	DECAL, DANGER ROTATING PARTS – DUTCH

ITEM	PART NO.	QTY	DESCRIPTION
	0151410G	1	DECAL, DANGER ROTATING PARTS – GERMAN
150	508228-001	2	DECAL, UPRIGHT LOGO
153	0083432	1	DECAL, LIFT /TIE DOWN LOCATION
250	0071926	1	DECAL, DIESEL FUEL – CUMMINS ENGINES
252	9980021	2	PLUG, HOLE 3.50 DIA PLASTIC – CUMMINS ENGINES
253	9980022	1	PLUG, HOLE 4.00 DIA PLASTIC – CUMMINS ENGINES
254	0084094	2	ACCESS COVER – CUMMINS ENGINES
258	0075563	1	DECAL, DO NUT USE ETHER – CUMMINS ENGINES
259	0075564	1	PLACARD, COLDSTART GLOW PLUGS – CUMMINS ENGINES
260	0084213	1	PLACARD, COLDSTART GLOW PLUGS – CUMMINS ENGINES
301	0071926	1	DECAL, DIESEL FUEL – DEUTZ ENGINES
302	9980021	1	PLUG, HOLE 3.50 DIA PLASTIC – DEUTZ ENGINES
303	9980022	1	PLUG, HOLE 4.00 DIA PLASTIC – DEUTZ ENGINES
305	0084094	1	ACCESS COVER – DEUTZ ENGINES
401	508235-001	2	DECAL, 4X4
451	0071793	1	DECAL, HYDRAULIC WARM-UP INSTRUCTIONS – OPTION
550	0084016E	4	DECAL, WHEEL LOADING

Specifications

Specifications

Aerial Platform

Working height	21.9 m (72')
Maximum platform height	20.1 m (66')
Horizontal reach	17.1 m (56')
Main boom	
Articulation	-1° to +72°
Extension	0 to 8.33 m (0 to 328")
Turntable rotation	360° continuous
Turning radius, inside	4.7m (15' 5")
Wheelbase	3 m (10')
Ground clearance	33 cm (13")
Maximum wheel load	5,900 kg (13,000 lbs)
Maximum ground pressure	11.3 kPa (78 psi)
Weight, GVW	
Approximate	11,916 kg (26,220 lbs)
Stowed width	2.4 m (7' 11.5")
Stowed length	10 m (33')
Stowed height	2.7 m (8' 9")

Platform

Dimensions	
Standard steel	76 cm x 152 cm (30" x 60")
Rated work load	227 kg (500 lb)
Optional aluminum	76 cm x 244 cm (30" x 96")
Rated work load	227 kg (500 lb)
Rotation	90° CW to 80° CCW
Maximum number of occupants	2 people
Optional AC generator	220 VAC

Function Speed

Turntable rotation, 360 degrees	165 to 175 seconds
Main boom	
Up	64 to 75 seconds
Down	64 to 75 seconds
Extend	65 to 75 seconds
Retract	35 to 45 seconds
Jib	
Up	7 to 13 seconds
Down	7 to 13 seconds
Platform rotation, 170 degrees	16 to 20 seconds
Drive	
High, booms stowed	4.8 km/h (3.0 mph)
Low, booms elevated	0.96 km/h (0.6 mph)

Drive System

Standard	Four wheel drive
Optional	Two wheel drive
Gradeability – theoretical 4x4	65%

Tires

Foam Filled, 12 ply	38 cm x 50 cm (15" x 19.5")
---------------------	-----------------------------

Electrical System

Voltage	12 V DC negative chassis ground
Source	Two - 12 V 550 CCA batteries
Fluid recommended	distilled water

Hydraulic System

Maximum pressure	17,250 kPa (2,500 psi)
Reservoir capacity	99 l (26.1 US gal)
System capacity	132 l (35 US gal)

Maximum operating temperature	93°C (200°F)
Hydraulic fluid recommended	
Above -12°C (10°F)	Mobil DTE-13M (ISO VG32)
Below -12°C (10°F)	Mobil DTE-11M (ISO VG15)

Engine

Diesel	Deutz F4L-2011F
--------	-----------------

Fuel Tank Capacity

Diesel	151 l (40 US gal)
--------	-------------------

Ambient Air Temperature Operating Range

Celsius	-18°C to 43°C
Fahrenheit	0°F to 110°F

Maximum Wind Speed

Gust or steady	45 km/h (28 mph)
----------------	------------------

Vibration

less than 2.5 m/sec²

Sound Threshold

below 100 dB(A)

Working Envelope

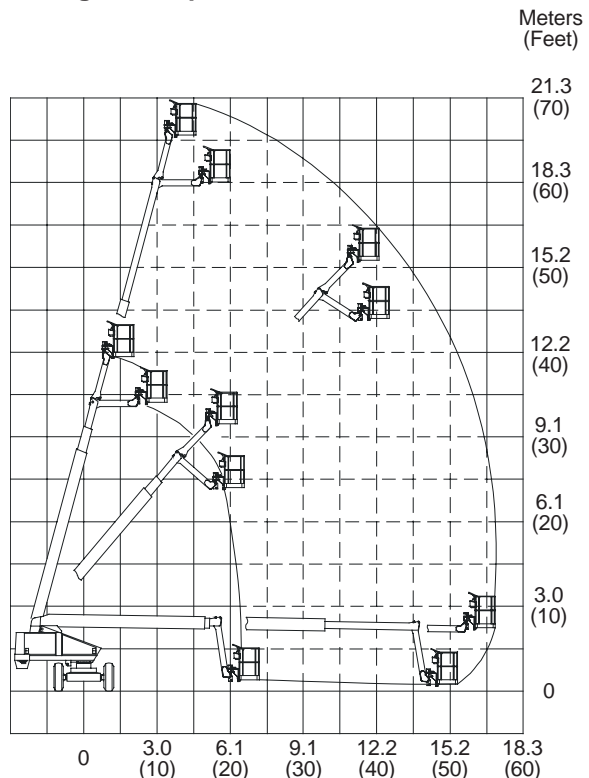

Local Distributor:

Lokaler Vertiebsshändler:

Distributeur local:

El Distribuidor local:

Il Distributore locale:

USA

TEL: +1 (559) 443 6600
FAX: +1 (559) 268 2433

UpRight
POWERED ACCESS

www.upright.com

Europe

TEL: +44 (0) 845 1550 058

PN- 508372-002-(EN)