

**COMPACT 8 (C 2032E) - COMPACT 8W (C 2047E) - COMPACT 10 (C 2747E) -  
COMPACT 10N (C 2632E) - COMPACT 10N-1 - COMPACT 12 (C 3347E) -  
COMPACT 14 (C 3947E)**

For online reference and to download the manuals for your machines HAULOTTE®, go to :  
<https://www.e.technical-information.com>  
or, scan the QR Code below :



Operator's manual

**Compact 8 (Compact 2032E)  
Compact 8W (Compact 2047E)  
Compact 10 (Compact 2747E)  
Compact 10N (Compact 2632E)  
Compact 10N-1  
Compact 12 (Compact 3347E)  
Compact 14 (Compact 3947E)**





# A

## FOREWORD

- 1 - User responsibility . . . . . 8**
  - 1.1- Owner's responsibility . . . . . 8
  - 1.2- Employer's responsibility . . . . . 8
  - 1.3- Trainer's responsibility . . . . . 8
  - 1.4- Operator's responsibility . . . . . 9
- 2 - Safety . . . . . 10**
  - 2.1 - Safety instructions . . . . . 10
  - 2.1.1 - Misuse Hazards . . . . . 10
  - 2.1.2 - Falling Hazards . . . . . 11
  - 2.1.3 - Overturning / Tip-over Hazards . . . . . 12
  - 2.1.4 - Electric Shock Hazards . . . . . 14
  - 2.1.5 - Explosion / Fire Hazards . . . . . 15
  - 2.1.6 - Crushing / Collision Hazards . . . . . 15
  - 2.1.7 - Uncontrolled movement Hazards . . . . . 16
- 3 - Safety inquiries . . . . . 17**
- 4 - Incident notification . . . . . 17**
- 5 - Compliance . . . . . 18**
  - 5.1 - Product modification . . . . . 18
  - 5.1.1 - Implementing manufacturer safety campaigns . . . . . 18
  - 5.2 - Product specifications . . . . . 18
  - 5.3 - Change of Ownership Notification . . . . . 19

# B

## FAMILIARIZATION

- 1 - General safety . . . . . 21**
  - 1.1 - Intended use . . . . . 21
  - 1.2 - Decal content . . . . . 22
  - 1.3 - Symbols and colors . . . . . 23
  - 1.4 - Level of severity . . . . . 23
  - 1.5 - Symbols legend and definitions . . . . . 24
- 2 - Models description . . . . . 25**
- 3 - Primary machine components . . . . . 26**
  - 3.1 - Layout . . . . . 26
  - 3.2 - Maintenance support . . . . . 28
  - 3.3 - manual extension . . . . . 29
  - 3.4 - Ground control box . . . . . 30
  - 3.4.1 - Layout . . . . . 30
  - 3.5 - Platform control box . . . . . 32
  - 3.5.1 - Layout . . . . . 32
- 4 - Performance Specifications . . . . . 34**
  - 4.1 - Technical characteristics . . . . . 34
  - 4.2 - Working area / Range of motion . . . . . 40
- 5 - Decals and markings locations . . . . . 48**

# CONTENTS



# C

## PRE-OPERATION INSPECTION

<b>1 - Recommendations</b> . . . . .	<b>63</b>
<b>2 - Working area assessment</b> . . . . .	<b>63</b>
<b>3 - Inspection and Functional test</b> . . . . .	<b>64</b>
3.1 - Daily inspection . . . . .	64
<b>4 - Safety functional checks</b> . . . . .	<b>67</b>
4.1 - E-Stop button check . . . . .	67
4.2 - Activation of controls . . . . .	68
4.3 - Fault detector . . . . .	68
4.3.1 - Buzzers test . . . . .	68
4.4 - Overload sensing system . . . . .	68
4.5 - Slope warning device . . . . .	69
4.6 - Travel speed limitation . . . . .	70
4.7 - Electronic variable speed drive . . . . .	70
4.8 - Pothole protection system . . . . .	71
4.9 - On-board charger . . . . .	71
4.10 - Battery discharge indicator-Hour meter . . . . .	72
4.10.1 - Hour meter . . . . .	72
4.10.2 - Alarm codes . . . . .	72

# D

## OPERATION INSTRUCTIONS

<b>1 - Operation</b> . . . . .	<b>73</b>
1.1 - Introduction . . . . .	73
1.2 - Operation from the ground control box . . . . .	74
1.3 - Operation from the platform control box . . . . .	75
<b>2 - Ground control box</b> . . . . .	<b>76</b>
2.1 - To start and stop the machine . . . . .	76
2.2 - Movement control . . . . .	76
2.3 - Additional controls from the ground control box . . . . .	77
<b>3 - Platform control box</b> . . . . .	<b>78</b>
3.1 - To start and stop the machine . . . . .	78
3.2 - Drive and steer control . . . . .	78
3.2.1 - Control box - Standard . . . . .	78
3.3 - Movement control . . . . .	79
3.3.1 - Control box - Standard . . . . .	79
3.4 - Additional controls . . . . .	79
<b>4 - Rescue and emergency procedures</b> . . . . .	<b>80</b>
4.1 - In case of power loss . . . . .	80
4.2 - To rescue operator in platform . . . . .	80





# CONTENTS

- 5 - Transportation . . . . . 81**
  - 5.1 - Putting in transport position. . . . . 81
  - 5.2 - Machine layout — COMPACT 8/ 8W / 10N / 10 / COMPACT 12 / COMPACT 14. . . . . 82
  - 5.3 - Unloading . . . . . 83
  - 5.4 - Towing. . . . . 84
    - 5.4.1 - Free wheel mode . . . . . 84
    - 5.4.2 - Automatic brake release (Option). . . . . 85
  - 5.5 - Storage . . . . . 86
  - 5.6 - Loading by ramp . . . . . 87
  - 5.7 - Unloading by ramp. . . . . 87
  - 5.8 - Lifting operation . . . . . 88
    - 5.8.1 - Safety precautions . . . . . 88
    - 5.8.2 - Preliminary procedures . . . . . 88
    - 5.8.3 - Loading and unloading with forklift. . . . . 89
    - 5.8.4 - For: COMPACT 8 - COMPACT 2032E - COMPACT 10N - COMPACT 2632E . . . . . 90
    - 5.8.5 - For COMPACT 8W - COMPACT 2047E - COMPACT 10 - COMPACT 2747E - COMPACT 12 - COMPACT 3347E - COMPACT 14 - COMPACT 3947E . . . . . 92
- 6 - Cold Weather Recommendations . . . . . 94**
  - 6.1 - Environmental conditions . . . . . 94
    - 6.1.1 - Hydraulic oil . . . . . 94
- 7 - Battery care and maintenance . . . . . 95**
  - 7.1 - Battery charging . . . . . 95

## E

### GENERAL SPECIFICATIONS

- 1 - Machine dimensions . . . . . 100**
- 2 - Major component masses . . . . . 102**
- 3 - Acoustics and vibrations . . . . . 103**
- 4 - Wheel/Tire assembly . . . . . 104**
  - 4.1 - Technical specifications. . . . . 104
  - 4.2 - Inspection and maintenance. . . . . 104
    - 4.2.1 - Procedure of replacement . . . . . 105
- 5 - Options . . . . . 106**
  - 5.1 - Pipe holder option . . . . . 106
    - 5.1.1 - Description . . . . . 106
    - 5.1.2 - Characteristics . . . . . 106
    - 5.1.3 - Safety precautions . . . . . 106
    - 5.1.4 - Pre-operation inspection . . . . . 107
    - 5.1.5 - Operation . . . . . 107
    - 5.1.6 - Disassembly - Assembly . . . . . 108
      - 5.1.6.1 - Without option . . . . . 108
      - 5.1.6.2 - Work light or platform supply option . . . . . 109
    - 5.1.7 - Specific decals . . . . . 110
  - 5.2 - Swing gate . . . . . 111
    - 5.2.1 - Description . . . . . 111
    - 5.2.2 - Characteristics . . . . . 111
    - 5.2.3 - Safety precautions . . . . . 111
    - 5.2.4 - Pre-operation instructions . . . . . 111



# F

## MAINTENANCE

- 1 - General** ..... 113
- 2 - Maintenance Schedule** ..... 114
- 3 - Inspection program** ..... 115
  - 3.1- General program ..... 115
  - 3.2- Daily inspection. .... 115
  - 3.3- Periodic inspection. .... 116
  - 3.4- Reinforced inspection ..... 116
  - 3.5- Major inspection ..... 117
- 4 - Repairs and adjustments** ..... 118

# G

## OTHER INFORMATION

- 1 - Conditions of warranty** ..... 119
- 2 - Subsidiary contact information** ..... 120
  - 2.1- California warning..... 121

# H

## INTERVENTION REGISTER

- 1 - Intervention register** ..... 123



# A- Foreword

A

B

C

D

E

F

G

H

I

You have just purchased a HAULOTTE® product and we would like to thank you for your business.

The aerial work platform is a device for lifting people designed and manufactured with the intent to enable users to access overhead elevated temporary workplaces with the necessary tools and equipment. All other uses or alterations/modifications to the aerial work platform must be approved by HAULOTTE®.

This manual shall be considered a permanent component of the machine and shall be kept with the aerial work platform in the designated Manual Holder, at all times.

Safe operation of this product can only be assured if you follow the operating instructions contained in this manual. To ensure proper and safe use of this equipment, it is strongly recommended that only trained and authorized personnel operate and maintain the aerial work platform.

We would particularly like to draw your attention to 2 essential points :

- Comply with safety instructions.
- Use the equipment within the specified/published performance limits.

With regard to the designation of our equipment, we stress that this is purely for commercial purposes and not to be confused with the technical specifications. Only the specifications in this manual should be used to study the suitability of the equipment for the intended use.

This operator's manual is specific to the HAULOTTE® products listed on the cover page of this manual.



#### Original language and version :

**Manuals in English and French are the original instructions. Manuals in other languages are translations of the original instructions.**

The operator's manual does not replace the basic training required for equipment operators. HAULOTTE® has compiled this manual to assist in safe and efficient operation of the products covered in the manual.

The manual must be available to all operators and must be kept in a legible condition. Additional copies can be ordered from HAULOTTE Services®.

**Stay Safe and keep working with HAULOTTE® !**

For online reference and to download the manuals for your machines HAULOTTE®, go to :

<https://www.e.technical-information.com>

or, scan the QR Code below :



# A - Foreword

## 1 - User responsibility

### 1.1 - OWNER'S RESPONSIBILITY

**The owner (or hirer) has the obligation to :**

- To inform operators of the instructions contained in the Operator's Manual.
- Follow local regulations regarding operation of the machine.
- To replace all manuals or decals that are either missing or not legible. Additional copies can be ordered from HAULOTTE Services®.
- To establish a preventive maintenance program in accordance with the manufacturer's recommendations, taking into account the environment and severity of use of the machine.
- To perform periodic inspections in accordance with HAULOTTE® recommendations and local regulations.

All malfunctions and problems identified during the inspection shall be corrected before the aerial work platform is returned to service.

### 1.2 - EMPLOYER'S RESPONSIBILITY

**The employer has the obligation :**

- To authorize the operator to use the machine.
- To inform and familiarize the operator with the local regulations.

Forbid anyone from operating the machine if :

- Under the influence of drugs, alcohol, etc.
- Subject to fits, loss of motor skills, dizziness, etc.

### 1.3 - TRAINER'S RESPONSIBILITY

The trainer must be qualified to provide training to operators in accordance with applicable local regulations. The training must be given in an obstacle-free area until the trainee is considered competent as defined by the training program undertaken.

# A - Foreword

## 1.4 - OPERATOR'S RESPONSIBILITY

### The operator has the obligation to :

- Read and understand the contents of this manual and familiarize himself with the decals affixed on the machine.
- To inspect the machine before use according to HAULOTTE®'s recommendations..
- Inform the owner (or hirer) if the manual or any decals are missing or are not legible.
- To inform of any malfunctioning of the machine.

Operators must ensure that the inspections have been carried out by the owner and that they can use the machine for the purpose intended by the manufacturer.

Only authorized and qualified operators may operate HAULOTTE® machines.

All operators must become familiar with and fully understand the emergency controls and be able to operate the machine in an emergency.

The operator has the obligation to stop using the machine in the event of malfunction or safety problems on the machine or in the work area and report the problem immediately to his/her supervisor.

A

B

C

D

E

F

G

H

I

# A - Foreword

## 2 - Safety

### 2.1 - SAFETY INSTRUCTIONS

#### 2.1.1 - Misuse Hazards

- Do not use the machine for other purposes than to lift people, their tools and equipment to the desired position.
- Do not use the machine as a crane, material lift or elevator. Only use the machine as it was intended.
- Do not attach overhanging loads when raising or lowering the platform.
- Do not tie the platform to an adjacent fixed or mobile structure.
- Do not use/operate the machine when alone. A survey person or immediate Supervisor must be present on the ground in case of emergency.
- Do not use a faulty or poorly maintained machine. Remove defective/damaged machine from service.
- Do not climb onto the compartment covers of the machine.
- Do not replace items critical to machine stability with items of different weight or specification.
- Do not replace factory-installed tires with tires of different specifications or ply rating.
- Do not alter or disable machine components that in any way affect safety and stability.
- Do not disable the safety devices.
- Do not deface, modify or obscure any decals or markings on the aerial work platform.



# A - Foreword

## 2.1.2 - Falling Hazards

### To enter or exit from the platform :

- The machine must be completely stowed.
- Face the machine to access the entry opening to the platform.
- Keep 3 points of contact (both hands and a foot) on the steps and the guardrail.
- Keep fingers away from moving parts near entry gate.



### Before commencing operation :

- Ensure that guard rails are correctly installed and secured.
- Ensure that gate or sliding bar is in its proper closed position.



- Remove oil or grease from the steps, floor, handrail and the guardrails.
- Clean the floor of the platform (no debris).

### When in the platform :

- If local regulations require the wearing of a harness, use only the anchor points provided for this purpose.
- The correct use of the harness requires the lanyard to be connected to an anchorage point designated by the decals. Refer to this decal located on the platform.
- Hold on securely to the guardrails.
- Always keep your feet firmly on the floor of the platform.
- Do not sit, stand, or climb on the platform guard rails.
- Do not lean over the guard rails or climb over them. Only work in the platform area within the guard rails.
- Do not exit the platform until it is in the completely stowed position.
- Do not use the guardrail as a means of access to climb in or out of the platform.



# A- Foreword

## 2.1.3 - Overturning / Tip-over Hazards

### Before positioning and operating the machine :

- Ensure that the surface is capable of supporting the machine weight including the rated capacity.
- Do not exceed the maximum rated capacity that includes the weight of both material and allowed number of occupants. Do not exceed the allowable number of occupants.
- Do not increase the working height (using extensions, ladder, etc.).
- Do not place ladders or scaffolds in the platform or against any part of this machine.
- Place the loads uniformly distributed on the platform floor.
- Do not use the machine in winds exceeding the permissible limit.
- Do not increase the surface area of the platform exposed to wind. This includes adding panels, mesh, banners. Be aware when working with materials with a large surface area. This will add to the wind load on the machine.
- Do not raise the platform or drive with platform elevated on an incline exceeding the rated slope for the machine.
- Do not drive the machine on slopes or grades exceeding the specified limits.
- Do not replace components critical to stability with components of different weight or specification.
- Never use the machine with material or objects suspended from the guard-rail.
- Do not pull or push towards any object outside of the platform. Do not exceed the maximum allowable side force stated in the performance specifications.
- Do not use the machine to support any external structure.
- Do not use the machine to tow other machines or to drag materials.





# A- Foreword

- Using a machine on a slope :



Do not drive the machine on slopes with gradients exceeding the authorised transversal and lateral limits for the machine.  Section B 4.1 - Technical specifications.

WIND : The aerial work platform can operate up to a maximum wind speed as indicated in the specifications. To identify the local wind speed, use the Beaufort scale below, use a wind gauge or an anemometer.

***N.B.-:-THE BEAUFORT SCALE OF WIND FORCE IS ACCEPTED INTERNATIONALLY AND IS USED WHEN COMMUNICATING WEATHER CONDITIONS. A WIND SPEED RANGE AT 10 M (32 FT 9 IN) ABOVE FLAT, CLEAR LAND IS ASSOCIATED WITH EACH DEGREE.***

### Beaufort scale

Force	Meteorological description	Observed effects	m/s	km/h	mph
0	Calm	Smoke rises vertically.	0 - 0,2	0 - 1	0 - 0,62
1	Very light breeze	Smoke indicates the wind direction.	0,3 - 1,5	1 - 5	0,62 - 3,11
2	Light breeze	Wind felt on the face. Leaves rustle. Weather vanes turn.	1,6 - 3,3	6 - 11	3,72 - 6,84
3	Slight breeze	Leaves and small twigs in constant motion. Flags move slightly.	3,4 - 5,4	12 - 19	7,46 - 11,8
4	Nice breeze	Raised dust and loose papers. Small branches are moved.	5,5 - 7,9	20 - 28	12,43 - 17,4
5	Nice breeze	Small trees in leaf to sway. Crested wavelets form on inland waterways.	8,0 - 10,7	29 - 38	18,02 - 23,6
6	Cool wind	Large branches in motion. Power lines and chimneys 'sing'. Umbrellas used with difficulty.	10,8 - 13,8	39 - 49	24,23 - 30,45
7	Near gale	Whole trees in motion. Inconvenience felt when walking against wind.	13,9 - 17,1	50 - 61	31 - 37,9
8	Gale	Some branches break. Generally we cannot walk against the wind.	17,2 - 20,7	62 - 74	38,53 - 45,98
9	Strong gale	The wind causes slight damage to buildings. Tiles and chimney stacks are blown off.	20,8 - 24,4	75 - 88	46,60 - 54,68

# A- Foreword

## 2.1.4 - Electric Shock Hazards

The machine is not electrically insulated and does not provide protection from contact or proximity to electrically charged conductors.

Always position the lift at a safe distance from electrically charged conductors to ensure that no part of the machine is within an unsafe area.

Respect the local rules and the minimum safety distance from power lines.

### Minimum safe approach distances

Electric voltage	Minimum safety distance	
	Mètre	Feet
0 - 300 V	Avoid contact	
300 V - 50 kV	3	10
50 - 200 kV	5	15
200 - 350 kV	6	20
350 - 500 kV	8	25
500 - 750 kV	11	35
750 - 1000 kV	14	45

**N.B.:-USE THIS TABLE EXCEPT WHERE LOCAL REGULATIONS INDICATE OTHERWISE.**

- Do not operate the machine when close to live power lines, consider the movement of the machine and the sway of the electric power lines particularly in windy conditions.
- Do not operate the machine during lightning, thunderstorms, snow/ice or any weather condition that could compromise operator safety.
- The machine must not be used while charging the batteries.
- When using the platform AC power supply, ensure it is protected with a circuit breaker and residual current device.
- Do not use the machine as a ground for welding.
- Do not weld on the machine without first disconnecting the battery terminals.
- Always disconnect ground cable first.



**Keep away from the machine if it contacts energized power lines. Personnel on the ground or in the platform must not touch or operate the machine until energized power lines are shut off.**



# A- Foreword

## 2.1.5 - Explosion / Fire Hazards

Always wear protective clothing and eye wear when working with batteries and power sources/systems.

**N.B.:-ACID IS NEUTRALIZED WITH SODIUM BICARBONATE AND WATER.**

- Do not work on or operate a machine in an explosive or flammable atmosphere / environment.
- Do not touch hot components.
- Do not bridge the battery terminals with metallic objects.
- Do not service the battery in proximity of spark, open flame, lit cigarettes.
- ALWAYS avoid contact with battery acid. Battery acid causes serious burns and should be kept away from skin or eyes. If contact occurs, flush with water and consult a physician immediately.



## 2.1.6 - Crushing / Collision Hazards

**When in the platform :**

- Check the work area for overhead clearance, for any obstacles besides and below the platform when raising/lowering the platform and or before driving.
- During movement, keep all the parts of the body inside the platform. Hold onto the guardrails on the opposite side to any surrounding structures. Take care to avoid trapping hands whilst holding the guardrails.
- To position machine close to a building/structure, use extension deck feature, instead of driving machine closer to structure.
- Always cordon off the area around the base of the machine to keep personnel and other equipment away from the machine while in use.
- Warn personnel not to work, stand, or walk under a raised boom/platform.
- Do not drive in reverse direction (opposite the field of vision).
- Always ensure that the chassis is never driven any closer than 1 m (3 ft 3 in) to holes, bumps, slopes, obstructions, debris and ground coverings that may hide holes and other dangers.
- Keep non-operating personnel at least 5 m (16 ft 5 in) away from the machine when driving.

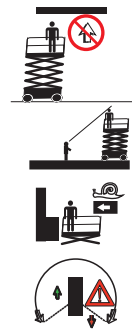

# A- Foreword

- Be aware of driving direction.
  - Check the driving direction with the help of the red or green arrow on the chassis relative to the red and green arrows on the platform control box.
  - Also note that when changing the driving direction (Forward <> Reverse) the joysticks or switches must return to the neutral position before reversing the drive direction and for movement to occur.
- When driving, position the platform so as to provide the best possible visibility and to avoid any blind spots.
- Hold on securely to the guardrails.
- Personal fall protection equipment (PFPE) :
  - Occupants must wear a safety harness, personal protective equipment and comply with the applicable national regulations. Attach the safety harness lanyard to the designated anchorage points provided for this purpose on the work platform.
  - Operators must comply with the safety standards of the job site and the employer, as well as the applicable state regulations relating to the use of personal protective equipment.
  - All personal fall protection equipment (PFPE) must comply with current regulations, must be inspected and used in accordance with the manufacturer's instructions.
- Avoid contact with fixed or mobile obstacles (other machines).
- Other machines (crane, aerial work platform, etc.) operating in the work area increase the risk of crushing or collision. Restrict the operation of machines moving within the aerial work platform work area.
- Take into consideration the stopping distance, reduced visibility and blind spots of the machine.
- Limit travel speed to suit the ground surface condition, slope (incline), and people in the vicinity.

## 2.1.7 - Uncontrolled movement Hazards

Never use a damaged or malfunctioning machine.

**Always respect the following rules :**

- Maintain clearance from high voltage lines.
- Maintain clearance from generators, radar, electromagnetic fields.
- Never expose the batteries or electrical components to water (high pressure washer, rain).

# A - Foreword

## 3 - Safety inquiries

Inquiries relating to design criteria/specifications of a product, standards compliance, or overall machine safety should be sent to the HAULOTTE® PRODUCT SAFETY department.

Each inquiry or request should include all relevant information; including contact name, telephone number, mailing address, email address, plus the machine model and serial number.

The HAULOTTE® Product Safety department will evaluate each request/inquiry and will provide a written response.

## 4 - Incident notification

Notify HAULOTTE® immediately when a HAULOTTE® product has been involved in an incident/accident leading to personal injury or death, or when there is a major property damage.

<p>HAULOTTE Group - EUROPE Product Safety Department</p> <p>Address : La Péronnière - BP 9 - 42152 L'Horme - France</p> <p>Tel : +33 (0)4 77 29 24 24</p> <p>Email : ProductSafety@haulotte.com</p>	<p>HAULOTTE Group - Australia, India and Asia Product Safety Department</p> <p>Address : No.26 Changi North Way - Singapore 498812 - Singapore</p> <p>Tel : +65 6546 0123</p> <p>Email : ProductSafety@haulotte.com</p>	<p>HAULOTTE Group - North &amp; South America Product Safety Department</p> <p>Address : 3409 Chandler Creek Rd. - Virginia Beach, VA 23453 - United States</p> <p>Tel : +1 757 689 2146</p> <p>Email : ProductSafety@haulotte.com</p>
---	---	--

Connect to our website : [www.haulotte.com](http://www.haulotte.com)



# A - Foreword

## 5 - Compliance

### 5.1 - PRODUCT MODIFICATION

It is strictly forbidden to modify a HAULOTTE® product. Any modification may violate Haulotte design parameters, local regulations and industry standards.

All modifications must be submitted in writing (form) and approved by the manufacturer.

Do not hesitate to contact HAULOTTE Services®, should you have any questions relating to the issued bulletin(s) or with questions on the policy itself.

#### 5.1.1 - Implementing manufacturer safety campaigns

It is essential to implement the safety campaigns issued by the manufacturer. All of these campaigns are accessible on our website.

Connect to our website : [www.haulotte.com](http://www.haulotte.com)



Never place a machine on the market without having applied the Safety Bulletins.

### 5.2 - PRODUCT SPECIFICATIONS

HAULOTTE® cannot be held liable for any changes to the technical characteristics/specifications contained in this manual. HAULOTTE® has a continuous improvement policy in place for its product range. Given this policy, the Company reserves the right to modify products technical characteristics / specifications without notice.

Certain options/accessories can modify the machine's operating characteristics and its' associated safety. If your machine was originally delivered with options fitted, replacing a safety component associated with a particular option does not require any particular precaution other than those associated with the installation itself (static test).

Otherwise, it is essential to follow the manufacturer's recommendations as stated below :

- Installation by authorised HAULOTTE® personnel only.
- Update the manufacturer's identification plate.
- Have stability tests carried out by a certified agency/competent person.
- Ensure decals are updated.

# A - Foreword

## 5.3 - CHANGE OF OWNERSHIP NOTIFICATION

It is important and necessary to keep HAULOTTE Services® updated with current ownership of the machine. This way, HAULOTTE® will be able to provide the necessary support for the product. If you have sold or transferred this machine(s); it is your responsibility to notify HAULOTTE Services®. It is not required to include Lessees/Renters of Leased/Rented machines on this form.

Connect to our website. : [www.haulotte.com](http://www.haulotte.com)



A

B

C

D

E

F

G

H

I





# B - Familiarization

## 1 - General safety

### 1.1 - INTENDED USE

Do not operate the product in the following situations :

- On soft, unstable or cluttered ground.
- With wind blowing faster than the permissible limit :
  - Check the allowable wind speed specified in the performance specifications tabulation.
  - Consult the Beaufort scale.
- Close to power lines. Keep a safe distance.
- If the machine is stored at a temperature out of range - 20°C / + 50°C (- 4°F / + 122°F).
- In an explosive atmosphere / environment.
- During storms.
- In the presence of strong electromagnetic fields.

***N.B.-:USE THE MACHINE UNDER "NORMAL" CLIMATIC CONDITIONS. IF YOU NEED TO USE THE MACHINE IN CLIMATIC CONDITIONS LIKELY TO CAUSE DETERIORATION (EXTREME : HUMIDITY, TEMPERATURES, SALINITY, CORROSIVENESS, ATMOSPHERIC PRESSURE), CONTACT HAULOTTE SERVICES®. REDUCE INTERVALS BETWEEN SERVICING.***

***N.B.-:WHILE THE MACHINE IS NOT IN USE, CARE MUST BE TAKEN TO BRING THE MACHINE TO THE FULLY STOWED POSITION. ENSURE THAT THE MACHINE IS LOCKED IN A SECURE LOCATION, AND THE CONTROL KEY IS REMOVED TO PREVENT UNAUTHORISED USE OF THE MACHINE.***

# B- Familiarization

## 1.2 - DECAL CONTENT

Decals are provided to alert the user of hazards inherent with the Aerial Work Platforms.

Decals provide the following information :

- The level of severity.
- The specific hazard.
- A method to avoid, suppress or reduce the hazard.
- Descriptive text (where required).

Familiarize yourself with the decals and the hazard severity levels.

Decals must be kept in good legible condition.

Familiarize yourself with the decals and their respective color codes.

Additional decals can be ordered from HAULOTTE Services®.

### CE and AS standards



### ANSI and CSA standards

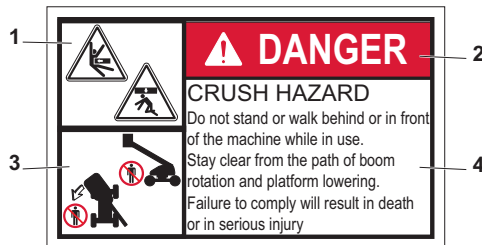







Marking	Description
1	Hazard symbol
2	Level of severity
3	Avoidance symbol pictorial
4	Avoidance text

# B- Familiarization











## 1.3 - SYMBOLS AND COLORS

Symbols and colors are used to alert the operator of safety precautions and/or to highlight important safety information.

The following safety symbols are used throughout this manual to indicate specific hazards and the hazard severity level when operating or maintaining the Aerial Work Platform.

Symbol	Description
	Danger : Risk of injury or death
	Caution : Risk of material damage
	Prohibited action
	Reminder to use good practice or follow pre-operation checks
	Cross-reference to another part of the manual
	Cross-reference to another manual
	Cross-reference to repair (contact HAULOTTE Services®)
N.B. :	Additional technical information

## 1.4 - LEVEL OF SEVERITY



































Color	Title	Description
	 <b>DANGER</b>	Danger : Indicates a hazardous situation which if not avoided, WILL result in death or serious injury.
	 <b>WARNING</b>	Warning : Indicates a hazardous situation which if not avoided, COULD result in death or serious injury.
	 <b>CAUTION</b>	Caution : Failure to comply could result in minor or moderate injury.
	 <b>NOTICE</b>	Notice : Indicates recommended practices if not followed, may result in a malfunction or damage the machine or its components.
	 <b>PROCEDURE</b>	Procedure : Indicates a maintenance operation.

# B- Familiarization

## 1.5 - SYMBOLS LEGEND AND DEFINITIONS

Symbols are used throughout this manual to depict hazards, avoidance measures and indicate when information is required.

Refer to the following table to familiarize yourself with these symbols.

Symbol	Description	Symbol	Description	Symbol	Description
	Body crushing hazard		Foot crushing hazard		High pressure fluid ejection hazard
			Hand crushing hazard		Entanglement hazard
			Health/safety hazards related to chemicals		Health-damaging effects from hot work environment
	Electrical contact or lightning strike		Burns and scalds from contact with flames, explosion or radiation from heat sources		Injury from Electric arcs - Energy supply disconnecting devices - Batteries fire, emissions, etc
	Risk of operator(s) falling		Tip over due to excessive loading / wind load and excessive ground slope		Relate and coordinate directional arrows on the chassis with those on the control box
	Do not put foot in this area		Do not put your hand in this area		Keep away from product working area
	Never expose batteries and electrical component to high pressure washer		Ensure entry drop rail is down		
	Flames prohibited		Maintain safe clearance from high voltage electrically charged conductors as described in manual - Do not use in thunderstorms		Overload
	Refer to operator manual		Safety belt		Use appropriate lanyard attached to dedicated anchor point.
	Wheel pressure		Enable switch		Use safety prop before attempting any maintenance work
	Tow point		Tie down point		Lift point
	Keep away from hot surfaces		Wear protective equipment		

# B - Familiarization

## 2 - Models description

Regulations	Models
ANSI and CSA standards	COMPACT 2032E
	COMPACT 2047E
	COMPACT 2747E
	COMPACT 2632E
	COMPACT 3347E
	COMPACT 3947E
CE, AS and EAC standards	COMPACT 8
	COMPACT 8W
	COMPACT 10
	COMPACT 10N
	COMPACT 10N-1
	COMPACT 12
	COMPACT 14

A

B

C

D

E

F

G

H

I

# B - Familiarization

## 3 - Primary machine components

### 3.1 - LAYOUT

**COMPACT 8 - COMPACT 2032E - COMPACT 8W - COMPACT 2047E -  
 COMPACT 10N - COMPACT 2632E - COMPACT 10 - COMPACT 2747E -  
 COMPACT 12 - COMPACT 3347E - COMPACT 14 - COMPACT 3947E**

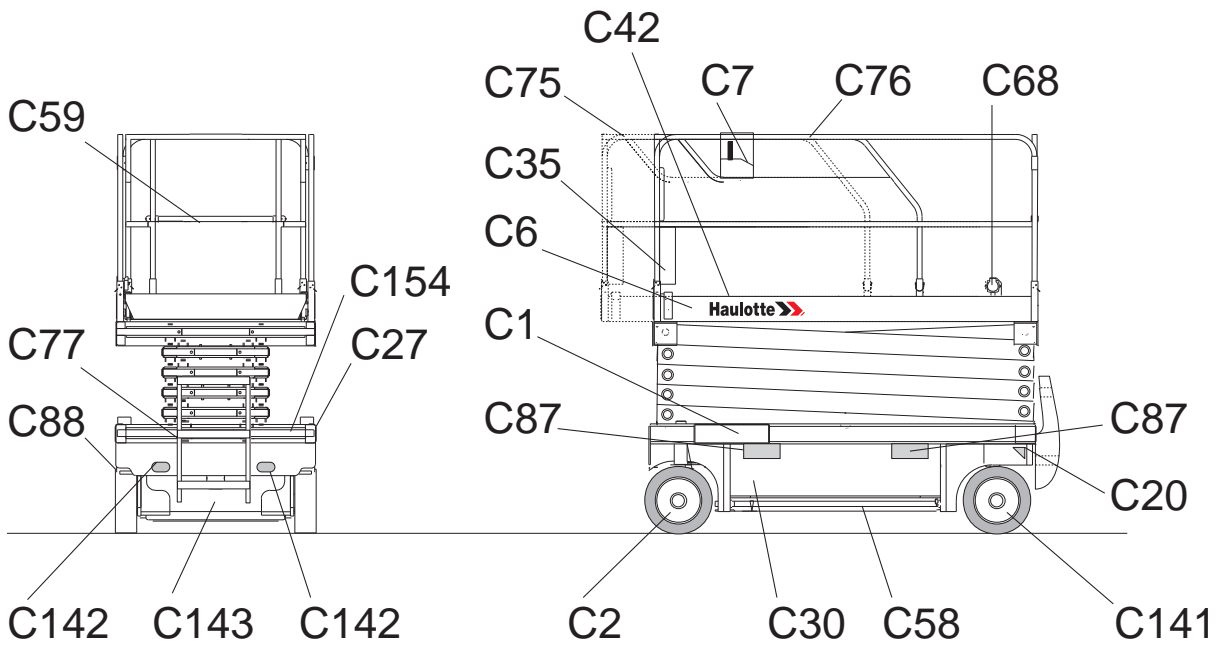

# B- Familiarization

Marking	Description	Marking	Description
C1	Chassis	C59	Hinged midrail
C2	Front driven steering axle	C68	Electric socket (Option)
C6	Platform	C75	Extension
C7	Platform control box	C76	Guardrail
C20	Tie-down (and/or lifting) points	C77	Platform access ladder
C27	Ground control box + Universal plug	C87	Position of the lift truck forks
C30	Hydraulic oil tank	C88	Battery drawer lock
C35	Document holder	C141	Rear wheel
C42	Foot Switch (For Japan only)	C142	Machine anchorage point
C58	Pothole protection	C143	Battery drawer

**Universal plug**





# B- Familiarization

## 3.2 - MAINTENANCE SUPPORT

The maintenance stand must be in place before any maintenance operation is begun.

**COMPACT 8 (C 2032E) -  
COMPACT 8W (C 2047E)**



**COMPACT 10 (C 2747E)**



**COMPACT 10N (C 2632E) -  
COMPACT 10N-1**



**COMPACT 12  
(C 3347E)**



**COMPACT 14 (C 3947E)**

The maintenance support (on both sides of the machine) must be put in place before any maintenance operations.



### Placing the machine in maintenance configuration :

- Lift scissor arms to a sufficient height to tilt the stand.
- Unscrew, rotate and put the stand in the vertical position.
- The stand should remain in the vertical position.
- Lower the scissor arms.
- Scissor arm pivoting rod should rest on the V groove of the stand.

### Putting in use position :

- To put back the machine into its normal operation, reverse the steps used above.



# B- Familiarization

## 3.3 - MANUAL EXTENSION

Machines are equipped with manual extension with several possible positions.

For : C8 (COMPACT 2032E) - C8W (COMPACT 2047E) - C10N (COMPACT 2632E) -  
C10 (COMPACT 2747E) - C12 (COMPACT 3347E) - C14 (COMPACT 3947E)

- Press the pedal.
- Push to the required notch.



***N.B.-:DO NOT LOAD THE EXTENSION DECK, FOR EASE OF MANOEUVRING.***



The extension deck must be retracted and locked during transport or towing.

# B- Familiarization

## 3.4 - GROUND CONTROL BOX

### 3.4.1 - Layout

General view - COMPACT 8 - COMPACT 2032E - COMPACT 8W - COMPACT 2047E -  
COMPACT 10 - COMPACT 2747E - COMPACT 10N - Compact 2632E - COMPACT 10N-1 -  
COMPACT 12 - COMPACT 3347E - COMPACT 14 - COMPACT 3947E

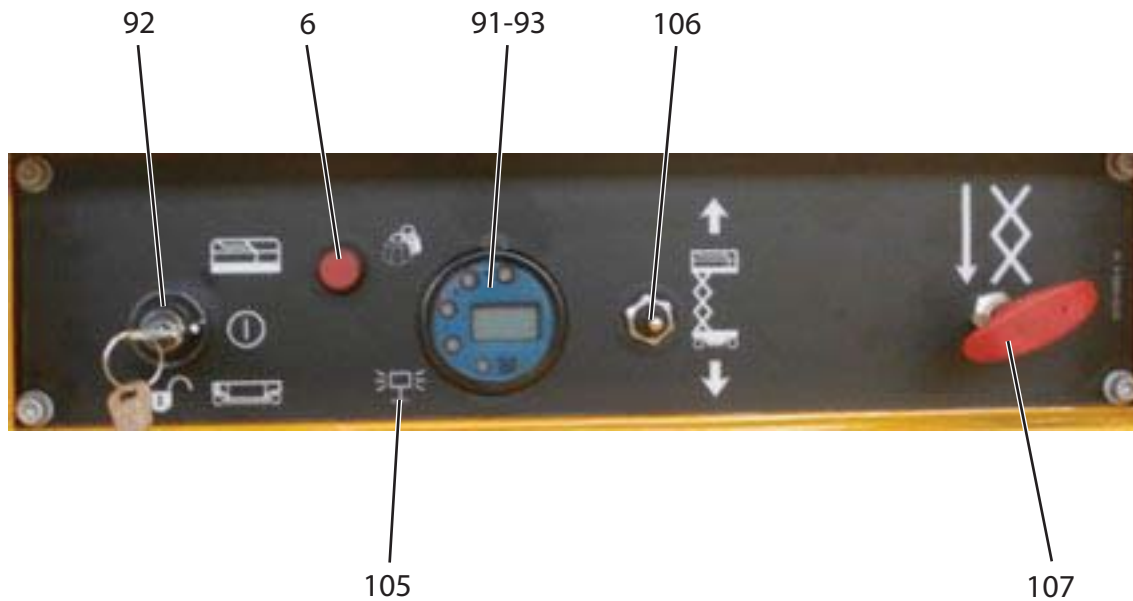

### E-stop button

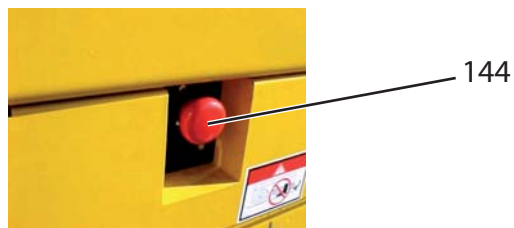

# B- Familiarization

## Controls and indicators

Marking	Description	Function
6	Platform overload indicator	Platform overload indicator
91	Hour meter-Battery charging indicator	Total machine running hours-Battery charger status
92	Control box activation key switch	Move upwards ; Move to the left : Platform control box energized
		Center : De-energizes control system
		Move downwards ; Move to the right : Ground control box energized
93	Battery charging indicator	Battery charge level status during battery charging
105	Flashing light selector	Move upwards : Switching on the flashing light
		Move downwards : Switching off the flashing light
106	Platform raising / lowering selector	Move upwards : Platform raises
		Move downwards : Platform lowers
107	Pull T-handle for emergency lowering	Pulled out : Platform lowers
		Release : Stops platform lowering
144	E-stop button-Cut-off	Pulled out : Ground control box energized
		Pushed in : De-energizes control system

A

B

C

D

E

F

G

H

I

# B- Familiarization

## 3.5 - PLATFORM CONTROL BOX

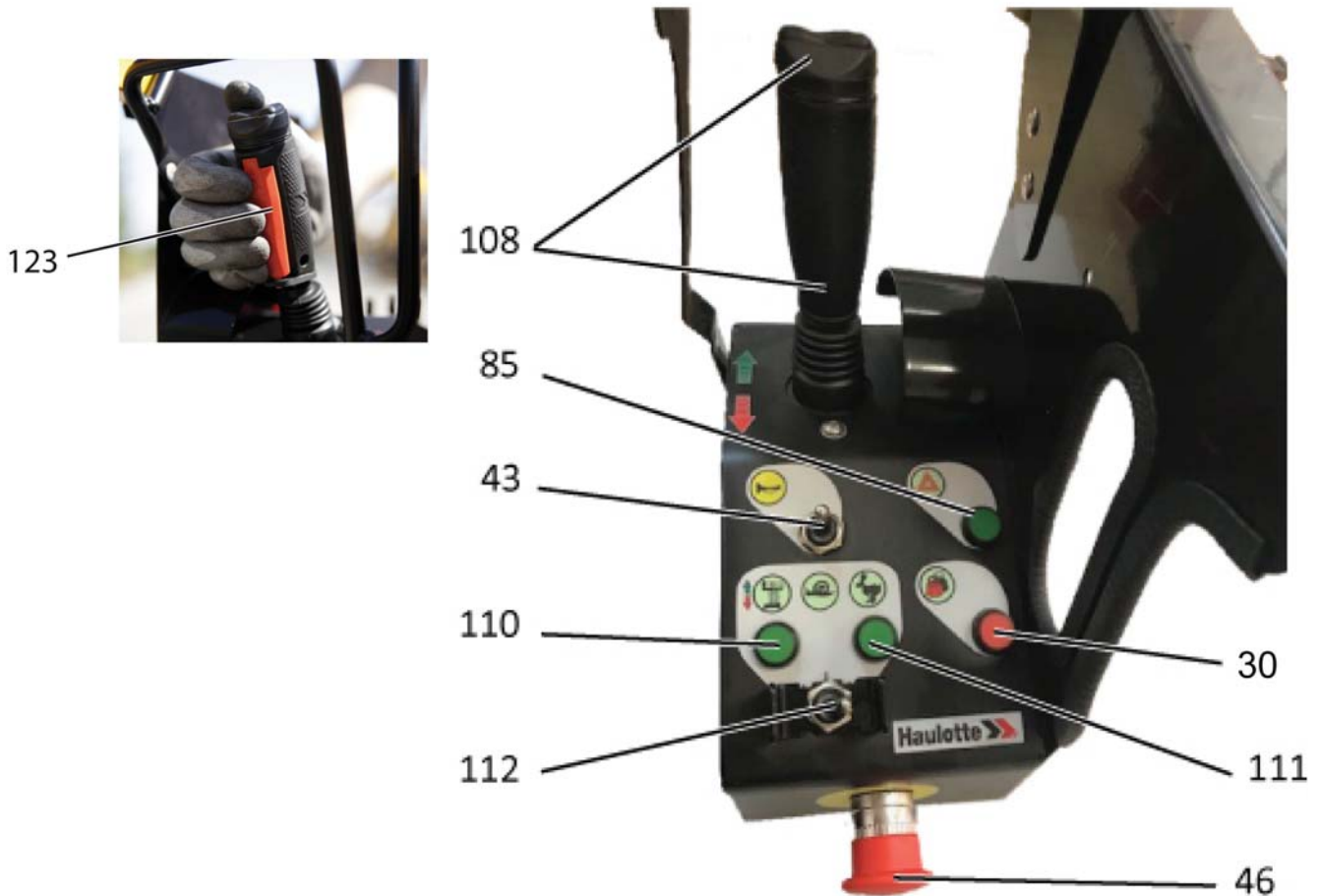

### 3.5.1 - Layout

General view - COMPACT 8 - COMPACT 2032E - COMPACT 8W - COMPACT 2047E -  
COMPACT 10 - COMPACT 2747E - COMPACT 10N - COMPACT 2632E - COMPACT 10N-1 -  
COMPACT 12 - COMPACT 3347E - COMPACT 14 - COMPACT 3947E



# B- Familiarization

## Controls and indicators

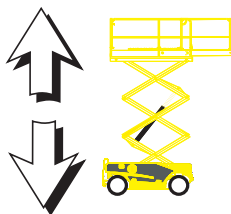
Marking	Description	Function
30	Overload indicator	Platform overloaded
43	Horn button	Horn
46	E-stop button	Pulled out : Ground control box energized
		Pushed in : De-energizes control system
85	Fault indicator	Faulty or tilting machine
108	Movement joystick	Move forward : Forward drive or platform raising
		Move backwards : Reverse drive or platform lowering
	Front axle steering selector	Press right side of button : Right-hand steering
		Press left side of button : Left-hand steering
110	Elevation / Lowering selection indicator	On : Raising / Lowering selection activated
		Off : Raising / Lowering movement is not selected
111	Driving selection indicator	On : Driving function activated
		Off : Driving movement is not selected
112	3-position selector	 high-speed driving
		 low-speed driving
		 Platform elevation/lowering
123	Enable Switch	Press in and hold : Associated command is validated
		Release : Associated command movement is halted

A

B

C

D

E

F

G

H

I

# B - Familiarization



## 4 - Performance Specifications

### 4.1 - TECHNICAL CHARACTERISTICS

Use the table to select the right Haulotte machine for the job.

**N.B.:-DO NOT REPLACE PARTS THAT ARE ESSENTIAL TO THE STABILITY OF THE MACHINE, SUCH AS BATTERIES OR TYRES, WITH PARTS THAT HAVE A DIFFERENT WEIGHT OR DIFFERENT SPECIFICATIONS. THE STABILITY OF THE MACHINE COULD BE AFFECTED.**

**CE, AS, EAC, CSA and ANSI A92.20 standards**

Machine	COMPACT 8	COMPACT 2032E	COMPACT 8W	COMPACT 2047E
Characteristics	Metric	Imperial	Metric	Imperial
Length of machine in stowed position	2,48 m	8 ft 2 in	2,45 m	8 ft 0 in
Overall width of machine	0,81 m	0 ft 32 in	1,20 m	3 ft 11 in
Platform length	2,30 m	7 ft 7 in	2,30 m	7 ft 7 in
Number of extensions	1		1	
Machine height	1,99 m	6 ft 6 in	2,14 m	7 ft 0 in
Maximum overall height of the machine in folded/stowed position guard-rail dismounted	1,14 m	3 ft 9 in	-	-
Maximum ground clearance	0,125 m	0 ft 5 in	0,13 m	0 ft 5 in
Transport height	1,99 m	6 ft 6 in	1,28 m	4 ft 2 in
Maximum working height	8,18 m	26 ft 10 in	8,27 m	27 ft 2 in
Maximum platform height	6,18 m	20 ft 3 in	6,27 m	20 ft 7 in
Platform width	0,92 m	3 ft 0 in	1,20 m	3 ft 11 in
Outside turning radius	2,38 m	7 ft 9 in	2,50 m	8 ft 2 in
Inside turning radius	0,34 m	1 ft 1 in	0,20 m	0 ft 7 in
Distance between centres of the wheels	1,86 m	6 ft 1 in	1,86 m	6 ft 1 in
Rated slope	2 °		3 °	
Maximum wind speed	Indoor use : 0 km/h (0 mph) Outdoor use : 45 km/h (28 mph)		Indoor use : 0 km/h (0 mph) Outdoor use : 45 km/h (28 mph)	
Total weight	1655 kg	3649 lb	2030 kg	4476 lb
Maximum platform load	Indoor use : 350 kg(773 lb) Outdoor use : 120 kg(265 lb)		Indoor use : 450 kg(1000 lb) Outdoor use : 450 kg(1000 lb)	
Recommended load capacity when extended	150 kg	331 lb	150 kg	330 lb
Manual lateral force at platform	Indoor use : 40 daN(90 lbf) Outdoor use : 20 daN(45 lbf)		Indoor use : 40 daN(90 lbf) Outdoor use : 40 daN(90 lbf)	
Maximum number of occupants allowed	Indoor use : 2 Outdoor use : 1  Section B 5 - Decals and markings locations		Indoor use : 3 Outdoor use : 3  Section B 5 - Decals and markings locations	
Power source	24 V		24 V	
Hydraulic oil tank capacity	25 l	7 gal US	25 l	7 gal US
Battery	24 V-180 Ah		24 V-240 Ah	
Maximum climbable slope	25 %		23 %	
Tire type and/ or size	380 x 127 x 30		380 x 127 x 30	
Platform elevation time (when empty)	37 s		44 s	
Platform lowering time (when empty)	41 s		56 s	

# B- Familiarization

Machine	COMPACT 8	COMPACT 2032E	COMPACT 8W	COMPACT 2047E
Characteristics	Metric	Imperial	Metric	Imperial
Micro drive speed	1 km/h	0,6 mph	1 km/h	0,6 mph
Low drive speed	1,5 km/h	0,9 mph	1,5 km/h	0,9 mph
High drive speed	3,5 km/h	2,2 mph	3,5 km/h	2,2 mph
Hand vibration	< 2,5m/s <sup>2</sup>	< 98 in/s <sup>2</sup>	< 2,5 m/s <sup>2</sup>	< 98 in/s <sup>2</sup>
Feet vibration	< 0,5 m/s <sup>2</sup>	< 19 in/s <sup>2</sup>	< 0,5 m/s <sup>2</sup>	< 19 in/s <sup>2</sup>
Noise emission level	< 70 dB (A)		< 70 dB (A)	

A

B

C

D

E



F

G

H



I

# B- Familiarization

Machine	COMPACT 10	COMPACT 2747E	COMPACT 10N	COMPACT 2632E
Characteristics	Metric	Imperial	Metric	Imperial
Length of machine in stowed position	2,43 m	8 ft 0 in	2,48 m	8 ft 2 in
Overall width of machine	1,20 m	3 ft 11 in	0,81 m	2 ft 8 in
Platform length	2,30 m	7 ft 7 in	2,30 m	7 ft 7 in
Number of extensions	1		1	
Machine height	2,26 m	7 ft 5 in	2,17 m	7 ft 1 in
Maximum overall height of the machine in folded/stowed position guard-rail dismounted	1,40 m	4 ft 7 in	1,33 m	4 ft 4 in
Maximum ground clearance	0,13 m	0 ft 5 in	0,125 m	0 ft 5 in
Minimum ground clearance	-	-	0,030 m	0 ft 2 in
Transport height	1,40 m	4 ft 7 in	1,33 m	4 ft 4 in
Maximum working height	10,14 m	33 ft 3 in	10,08 m	33 ft 1 in
Maximum platform height	8,14 m	26 ft 8 in	8,08 m	24 ft 6 in
Platform width	1,20 m	3 ft 11 in	0,80 m	2 ft 7 in
Outside turning radius	2,50 m	8 ft 2 in	2,38 m	7 ft 9 in
Inside turning radius	0,20 m	0 ft 7 in	0,34 m	1 ft 1 in
Distance between centres of the wheels	1,86 m	6 ft 1 in	1,86 m	6 ft 1 in
Rated slope	2 °		2 °	
Maximum wind speed	Indoor use : 0 km/h (0 mph) Outdoor use : 45 km/h (28 mph)		Indoor use : 0 km/h (0 mph) Outdoor use : 0 km/h (0 mph)	
Total weight	2235 kg	4928 lb	2190 kg	4829 lb
Maximum platform load	Indoor use : 450 kg(1000 lb) Outdoor use : 450 kg(1000 lb)		Indoor use : 230 kg(507 lb) Outdoor use : 0 kg(0 lb)	
Recommended load capacity when extended	150 kg	330 lb	120 kg	265 lb
Manual lateral force at platform	Indoor use : 40 daN(90 lbf) Outdoor use : 20 daN(45 lbf)		Indoor use : 40 daN(90 lbf) Outdoor use : Prohibited	
Maximum number of occupants allowed	Indoor use : 2 Outdoor use : 1  Section B 5 - Decals and markings locations		Indoor use : 2 Outdoor use : 0  Section B 5 - Decals and markings locations	
Power source	24 V		24 V	
Hydraulic oil tank capacity	25 l	7 gal US	25 l	7 gal US
Battery	24 V-240 Ah		24 V-180 Ah	
Maximum climbable slope	23 %		23 %	
Tire type and/ or size	380 x 127 x 30		380 x 127 x 30	
Platform elevation time (when empty)	51 s		46 s	
Platform lowering time (when empty)	42 s		51 s	
Micro drive speed	1 km/h	0,6 mph	1 km/h	0,6 mph
Low drive speed	1,5 km/h	0,9 mph	1,5 km/h	0,9 mph
High drive speed	3,5 km/h	2,2 mph	3,5 km/h	2,2 mph
Hand vibration	< 2,5 m/s <sup>2</sup>	< 98 in/s <sup>2</sup>	< 2,5 m/s <sup>2</sup>	< 98 in/s <sup>2</sup>
Feet vibration	< 0,5 m/s <sup>2</sup>	< 19 in/s <sup>2</sup>	< 0,5 m/s <sup>2</sup>	< 19 in/s <sup>2</sup>
Noise emission level	< 70 dB (A)		< 70 dB (A)	



# B- Familiarization

Machine	COMPACT 12	COMPACT 3347E	COMPACT 14	COMPACT 3947E
Characteristics	Metric	Imperial	Metric	Imperial
Length of machine in stowed position	2,43 m	8 ft 0 in	2,475 m	8 ft 1 in
Overall width of machine	1,20 m	3 ft 11 in	1,206 m	3 ft 11 in
Platform length	2,30 m	7 ft 7 in	2,30 m	7 ft 7 in
Number of extensions	1		1	
Machine height	2,38 m	7 ft 10 in	2,505 m	8 ft 3 in
Maximum overall height of the machine in folded/stowed position guard-rail dismounted	1,53 m	5 ft 0 in	1,644 m	5 ft 5 in
Maximum ground clearance	0,13 m	0 ft 6 in	0,13 m	0 ft 5 in
Transport height	1,53 m	5 ft 0 in	-	-
Maximum working height	12 m	39 ft 4 in	13,80 m	45 ft 3 in
Maximum platform height	10 m	32 ft 10 in	11,80 m	38 ft 9 in
Maximum platform height (Japan)	9,80 m	32 ft 2 in	-	-
Platform width	1,20 m	0 ft 48 in	1,20 m	3 ft 11 in
Outside turning radius	2,5 m	8 ft 2 in	2,38 m	7 ft 10 in
Inside turning radius	0,2 m	0 ft 8 in	0,34 m	1 ft 1 in
Distance between centres of the wheels	1,86 m	6 ft 1 in	1,86 m	6 ft 1 in
Rated slope	2 °		2° / 3°	
Maximum wind speed	Indoor use : 0 km/h (0 mph) Outdoor use : 45 km/h (28 mph)		Indoor use : 0 km/h (0 mph) Outdoor use : Prohibited	
Total weight	2470 kg	5446 lb	3174 kg	6999 lb
Maximum platform load	Indoor use : 300 kg(662 lb) Outdoor use : 300 kg(662 lb)		Indoor use : 350 kg(772 lb) Outdoor use : Prohibited	
Recommended load capacity when extended	150 kg	(330 lb)	150 kg	330 lb
Manual lateral force at platform	Indoor use : 40 daN(90 lbf) Outdoor use : 20 daN(45 lbf)		Indoor use : 40 daN(90 lbf) Outdoor use : Prohibited	
Maximum number of occupants allowed	Indoor use : 2 Outdoor use : 1  Section B 5 - Decals and markings locations		Indoor use : 3 Outdoor use : Prohibited  Section B 5 - Decals and markings locations	
Power source	24 V		24 V	
Hydraulic oil tank capacity	25 l	7 gal US	25 l	7 gal US
Battery	24 V-240 Ah Option : 24 V-240 Ah (C5)		24 V-255 Ah Option : 24 V-240 Ah (C5)	
Maximum climbable slope	23 %		23 %	
Tire type and/ or size	380 x 127 x 30		380 x 127 x 30	
Platform elevation time (when empty)	83 s		68 s	
Platform lowering time (when empty)	52 s		54 s	
Micro drive speed	0,8 km/h	0,5 mph	0,85 km/h	0,5 mph
Low drive speed	1 km/h	0,6 mph	1,4 km/h	0,9 mph
High drive speed	2,1 km/h	1,3 mph	2,8 km/h	1,7 mph
Hand vibration	< 2,5 m/s <sup>2</sup>	< 98 in/s <sup>2</sup>	< 2,5 m/s <sup>2</sup>	< 98 in/s <sup>2</sup>
Feet vibration	< 0,5 m/s <sup>2</sup>	< 19 in/s <sup>2</sup>	< 0,5 m/s <sup>2</sup>	< 19 in/s <sup>2</sup>
Noise emission level	< 70 dB (A)		< 70 dB (A)	

# B- Familiarization

## CE and AS standards

Machine	COMPACT 8 CU	
	Metric	Imperial
Length of machine in stowed position	2,48 m	8 ft 2 in
Overall width of machine	0,81 m	0 ft 32 in
Platform length	2,30 m	7 ft 7 in
Number of extensions	1	
Machine height	1,99 m	6 ft 6 in
Maximum overall height of the machine in folded/stowed position guard-rail dismounted	1,14 m	3 ft 9 in
Maximum ground clearance	0,125 m	0 ft 5 in
Transport height	1,99 m	6 ft 6 in
Maximum working height	8,18 m	26 ft 10 in
Maximum platform height	6,18 m	20 ft 3 in
Platform width	0,92 m	3 ft 0 in
Outside turning radius	2,38 m	7 ft 9 in
Inside turning radius	0,34 m	1 ft 1 in
Distance between centres of the wheels	1,86 m	6 ft 1 in
Rated slope	2°	
Maximum wind speed	Indoor use : 0 km/h (0 mph) Outdoor use : 45 km/h (28 mph)	
Total weight	1875 kg	4134 lb
Maximum platform load	Indoor use : 300 kg(662 lb) Outdoor use : 300 kg(662 lb)	
Recommended load capacity when extended	150 kg	331 lb
Manual lateral force at platform	Indoor use : 40 daN(90 lbf) Outdoor use : 20 daN(45 lbf)	
Maximum number of occupants allowed	Indoor use : 2 Outdoor use : 1  Section B 5 - Decals and markings locations	
Power source	24 V	
Hydraulic oil tank capacity	25 l	7 gal US
Operating batteries	24 V-180 Ah	
Maximum climbable slope	25 %	
Tire type and/ or size	380 x 127 x 30	
Platform elevation time (when empty)	37 s	
Platform lowering time (when empty)	41 s	
Micro drive speed	1 km/h	0,6 mph
Low drive speed	1,5 km/h	0,9 mph
High drive speed	3,5 km/h	2,2 mph
Hand vibration	< 2,5 m/s <sup>2</sup>	< 98 in/s <sup>2</sup>
Feet vibration	< 0,5 m/s <sup>2</sup>	< 19 in/s <sup>2</sup>
Noise emission level	< 70 dB (A)	

# B- Familiarization

## AS standard

Machine	C10N-1	
Characteristics	Metric	Imperial
Length of machine in stowed position	2,48 m	8 ft 2 in
Overall width of machine	0,81 m	2 ft 7 in
Platform length	2,30 m	7 ft 7 in
Number of extensions	1	
Machine height	2,17 m	7 ft 1 in
Maximum overall height of the machine in folded/stowed position guard-rail dismounted	1,33 m	4 ft 4 in
Maximum ground clearance	0,125 m	0 ft 5 in
Minimum ground clearance	0,030 m	0 ft 2 in
Transport height	1,33 m	4 ft 4 in
Maximum working height	10,08 m	33 ft 1 in
Maximum platform height	8,08 m	26 ft 6 in
Platform width	0,80 m	2 ft 7 in
Outside turning radius	2,38 m	7 ft 9 in
Inside turning radius	0,34 m	1 ft 1 in
Distance between centres of the wheels	1,86 m	6 ft 1 in
Tilt sensor For AS only	2°	
Maximum wind speed	Indoor use : 0 km/h (0 mph) Outdoor use : 45 km/h (28 mph)	
Total weight	2448 kg	5398 lb
Maximum platform load	Indoor use : 230 kg(507 lb) Outdoor use : 120 kg(265 lb)	
Recommended load capacity when extended	120 kg	265 lb
Manual lateral force at platform	Indoor use : 40 daN(90 lbf) Outdoor use : Prohibited	
Maximum number of occupants allowed	 Section B 5 - Decals and markings locations	
Power source	24 V	
Hydraulic oil tank capacity	25 l(7 gal US)	
Battery	24 V-180 Ah	
Maximum climbable slope	23 %	
Tire type and/ or size	380 x 127 x 30 - No Marking	
Platform elevation time (when empty)	46 s	
Platform lowering time (when empty)	51 s	
Micro drive speed	1 km/h	0,6 mph
Low drive speed	1,5 km/h	0,9 mph
High drive speed	3,5 km/h	2,2 mph
Hand vibration	< 2,5 m/s <sup>2</sup>	< 98 in/s <sup>2</sup>
Feet vibration	< 0,5 m/s <sup>2</sup>	< 19 in/s <sup>2</sup>
Noise emission level	< 70 dB (A)	

# B- Familiarization

## 4.2 - WORKING AREA / RANGE OF MOTION

### COMPACT 8 - COMPACT 2032E

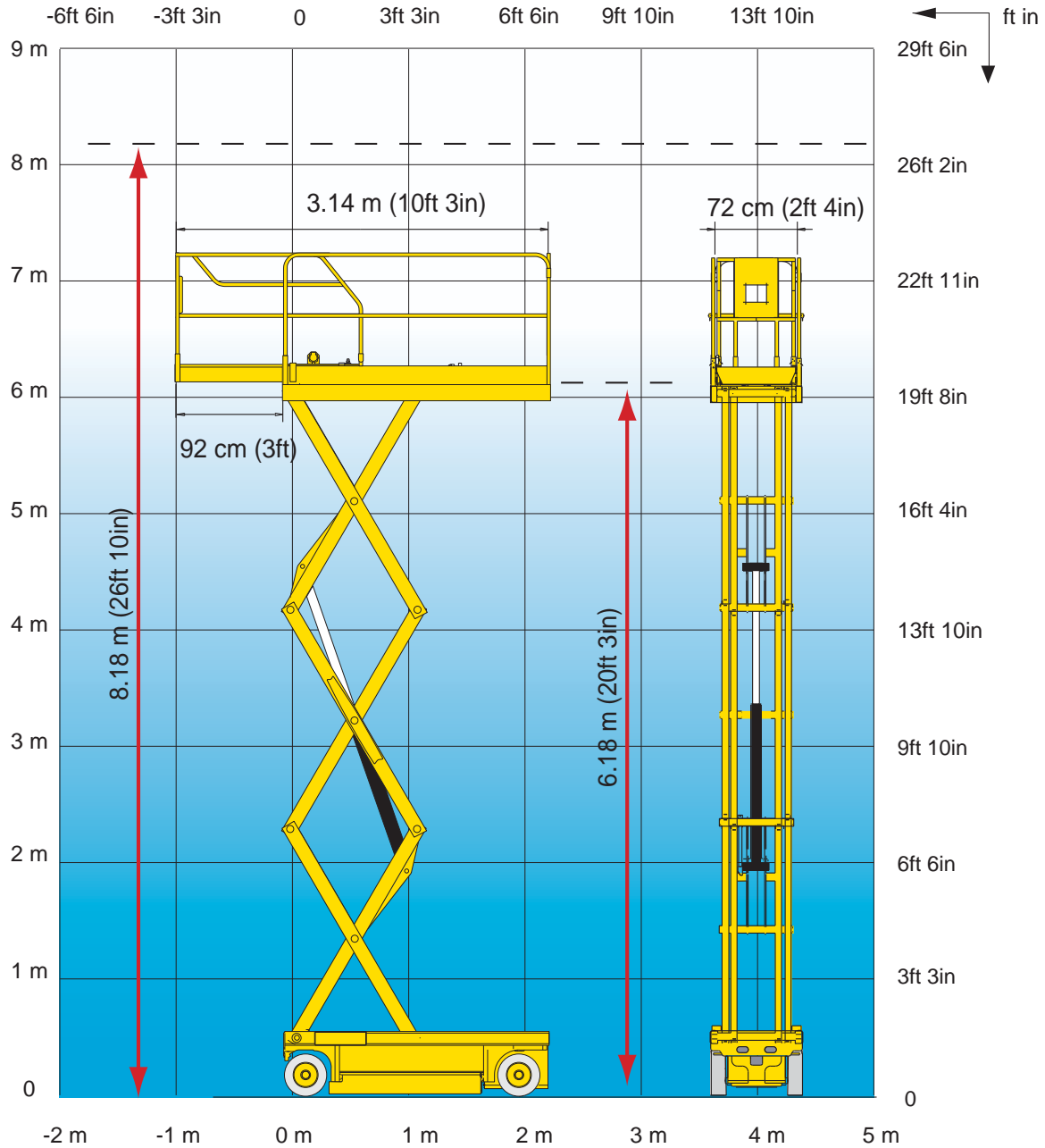

# B- Familiarization

## COMPACT 8W - COMPACT 2047E

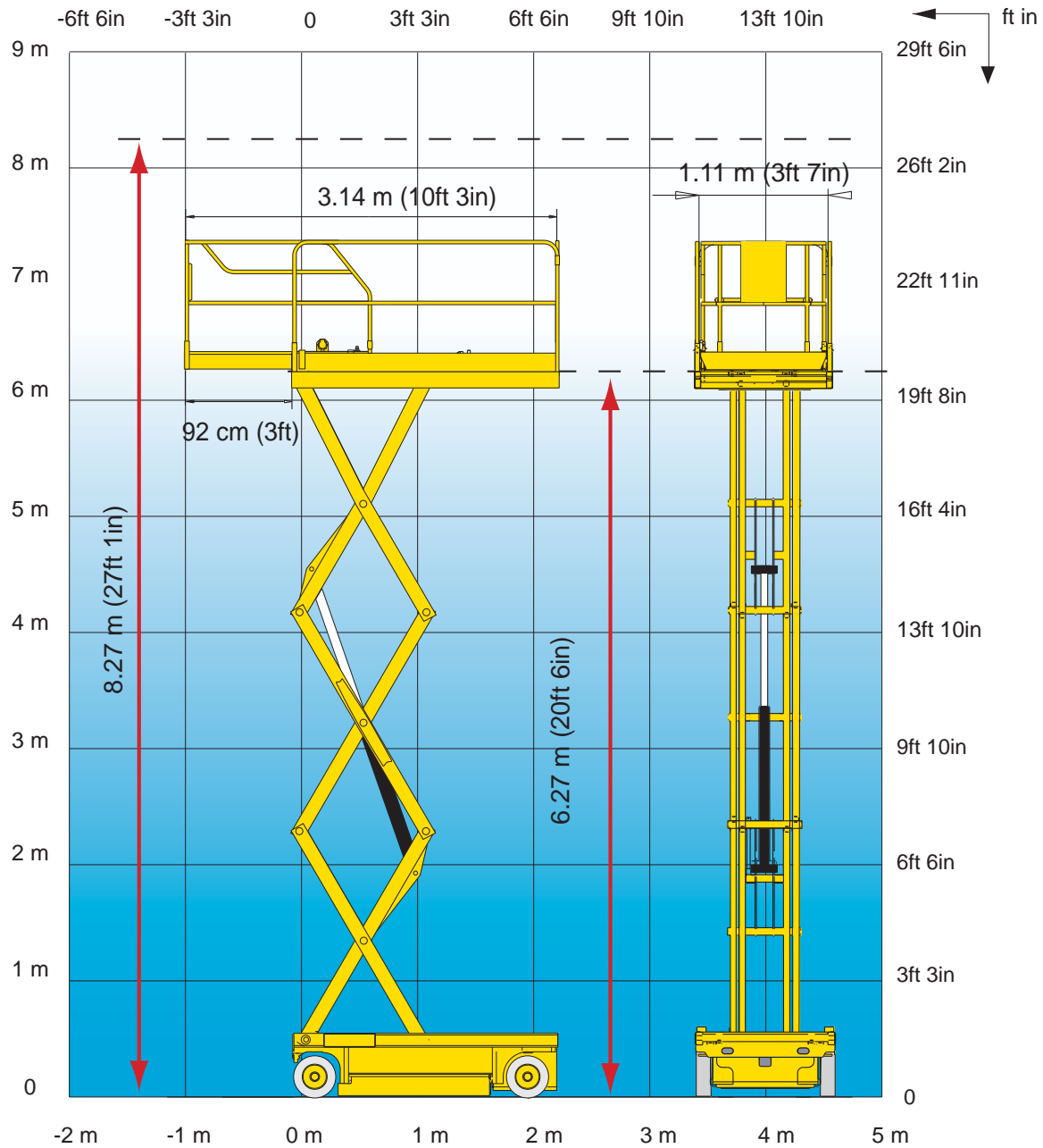

# B- Familiarization

## COMPACT 10N-COMPACT 2632E

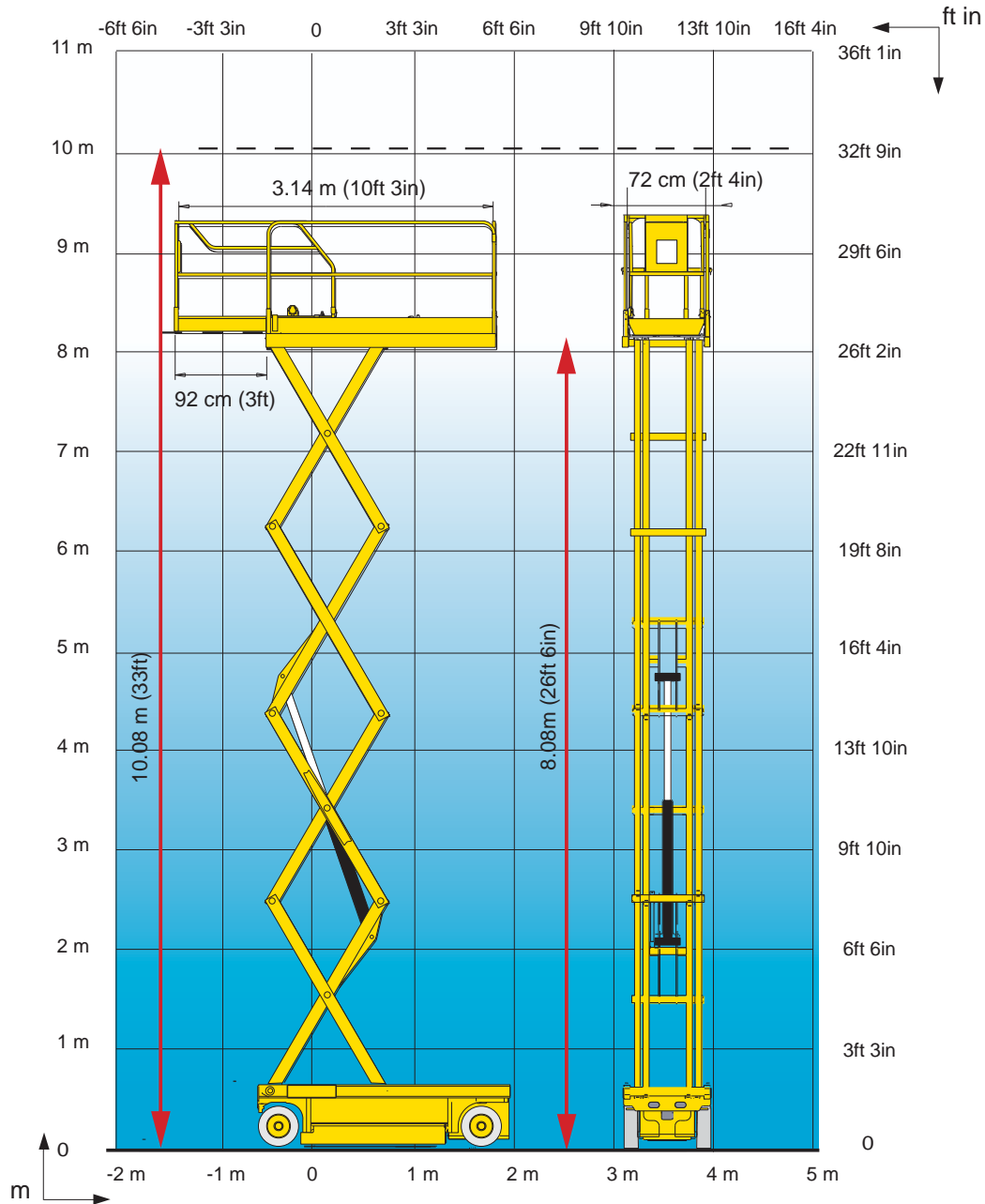

# B- Familiarization

## COMPACT 10 - COMPACT 2747E

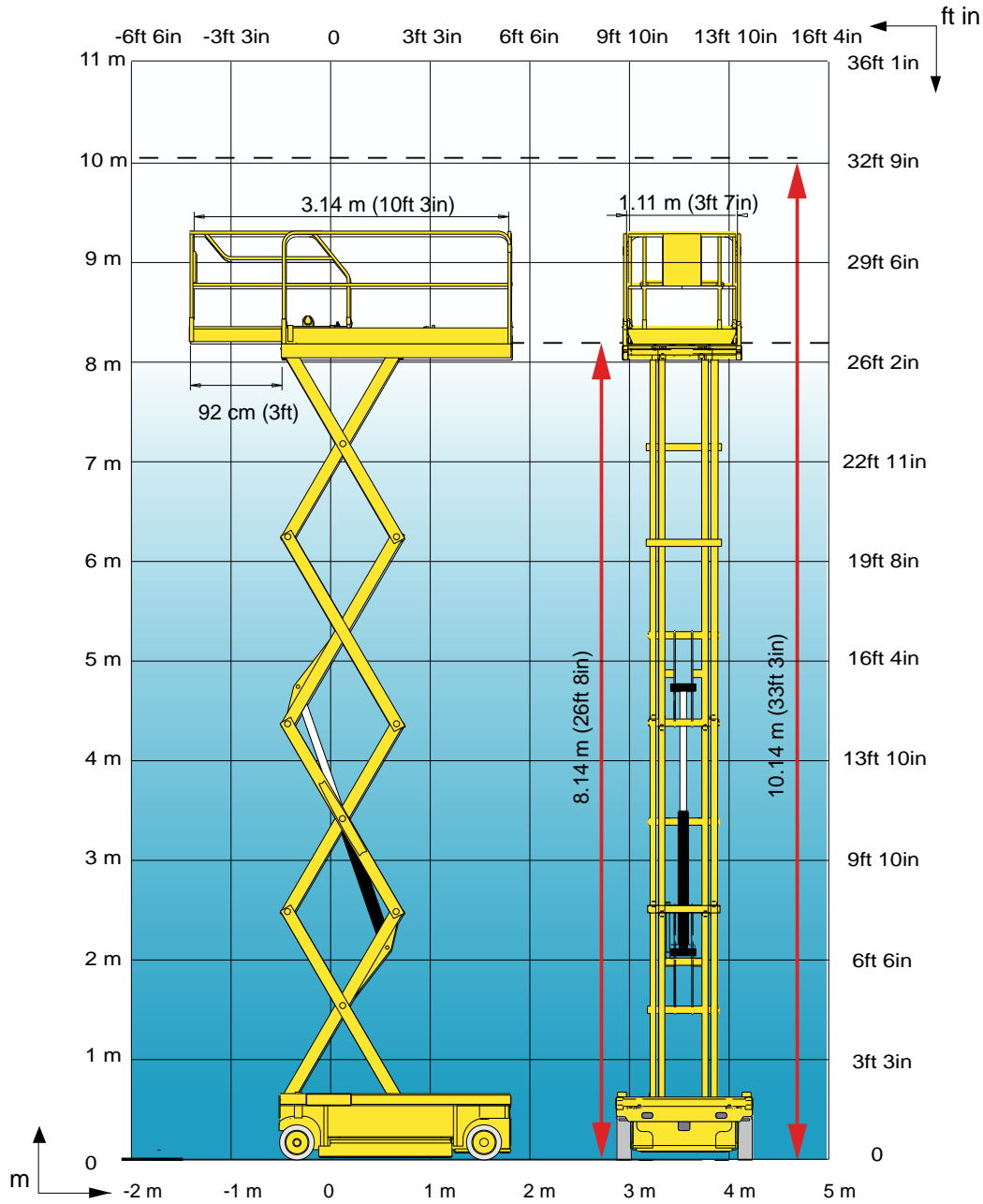

# B- Familiarization

## COMPACT 12 - COMPACT 3347E

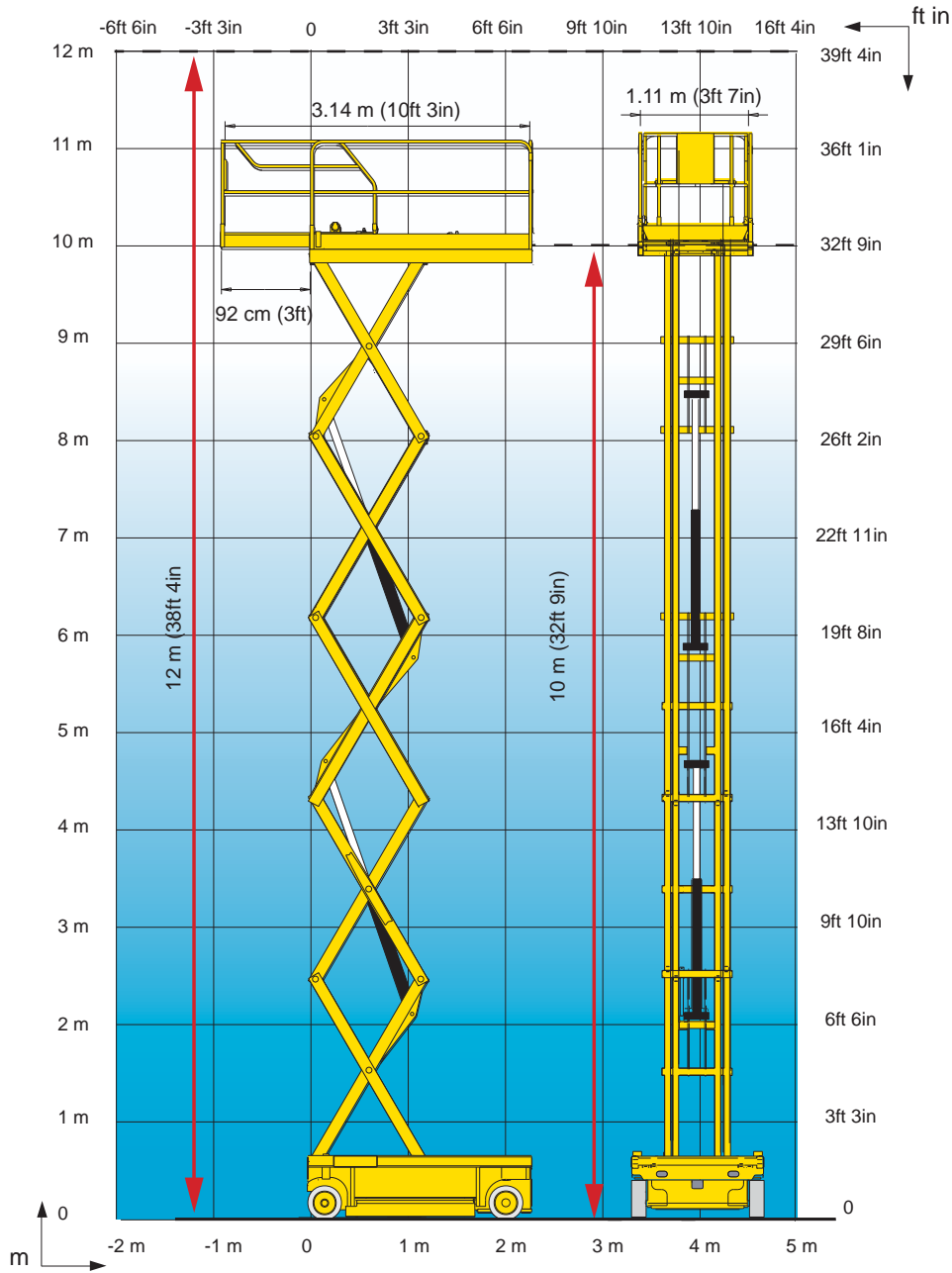



# B - Familiarization

## COMPACT 12 - COMPACT 3347E(Japan)

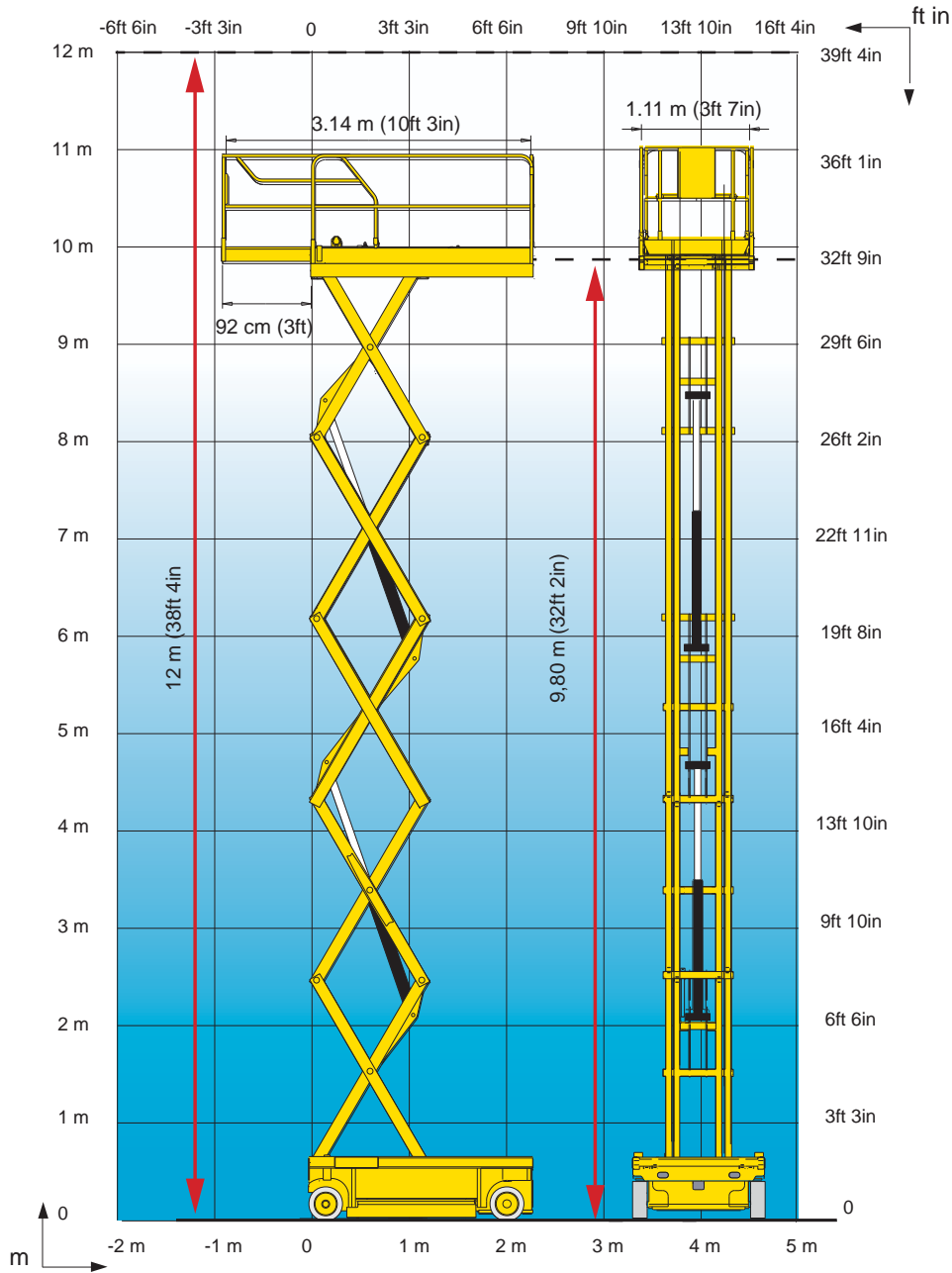

# B- Familiarization

## COMPACT 14 - COMPACT 3947E

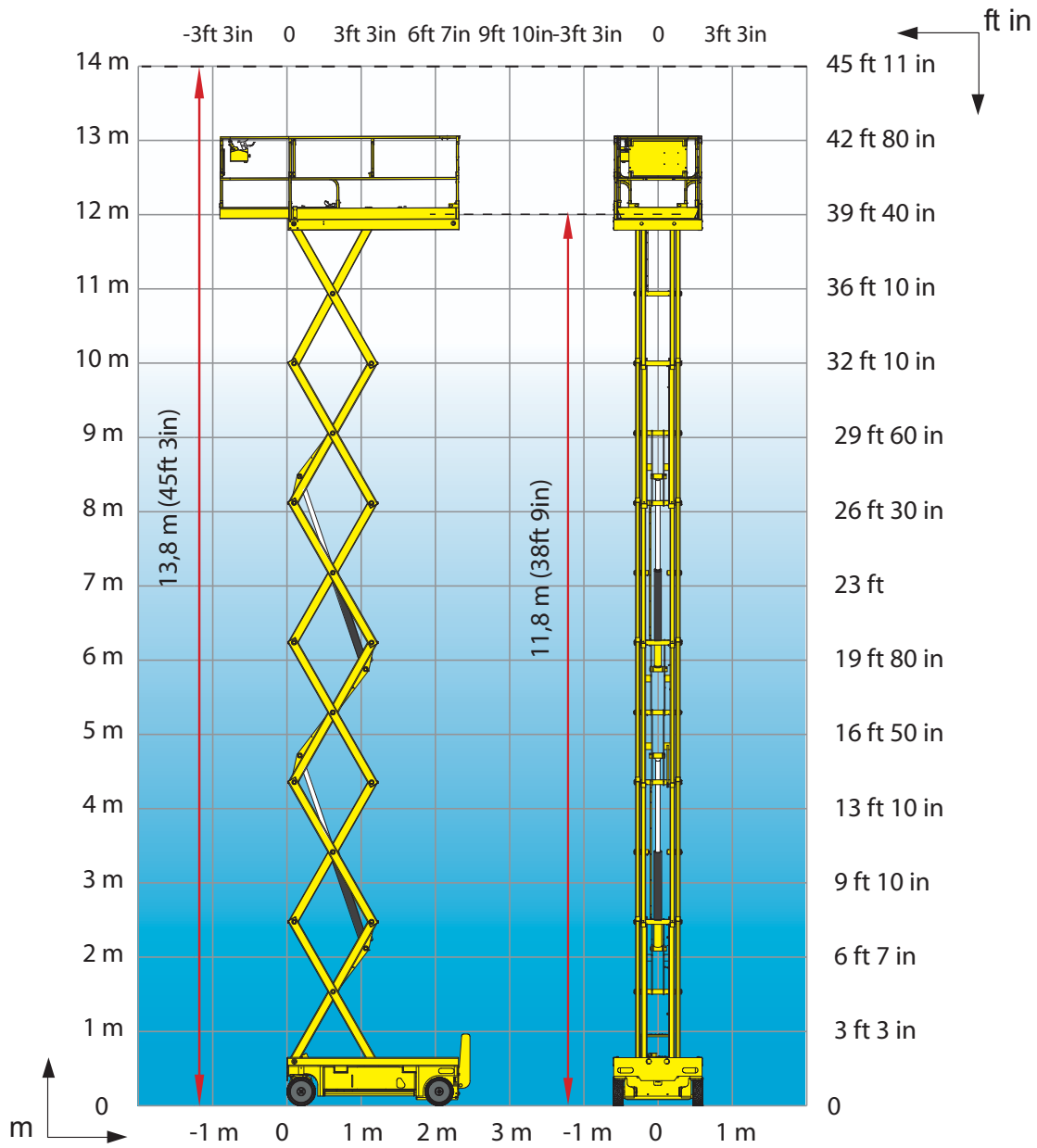



# B - Familiarization

## 5 - Decals and markings locations

CE and AS standards - 4000312830 F - COMPACT 8W - COMPACT 10 - COMPACT 12 - COMPACT 14

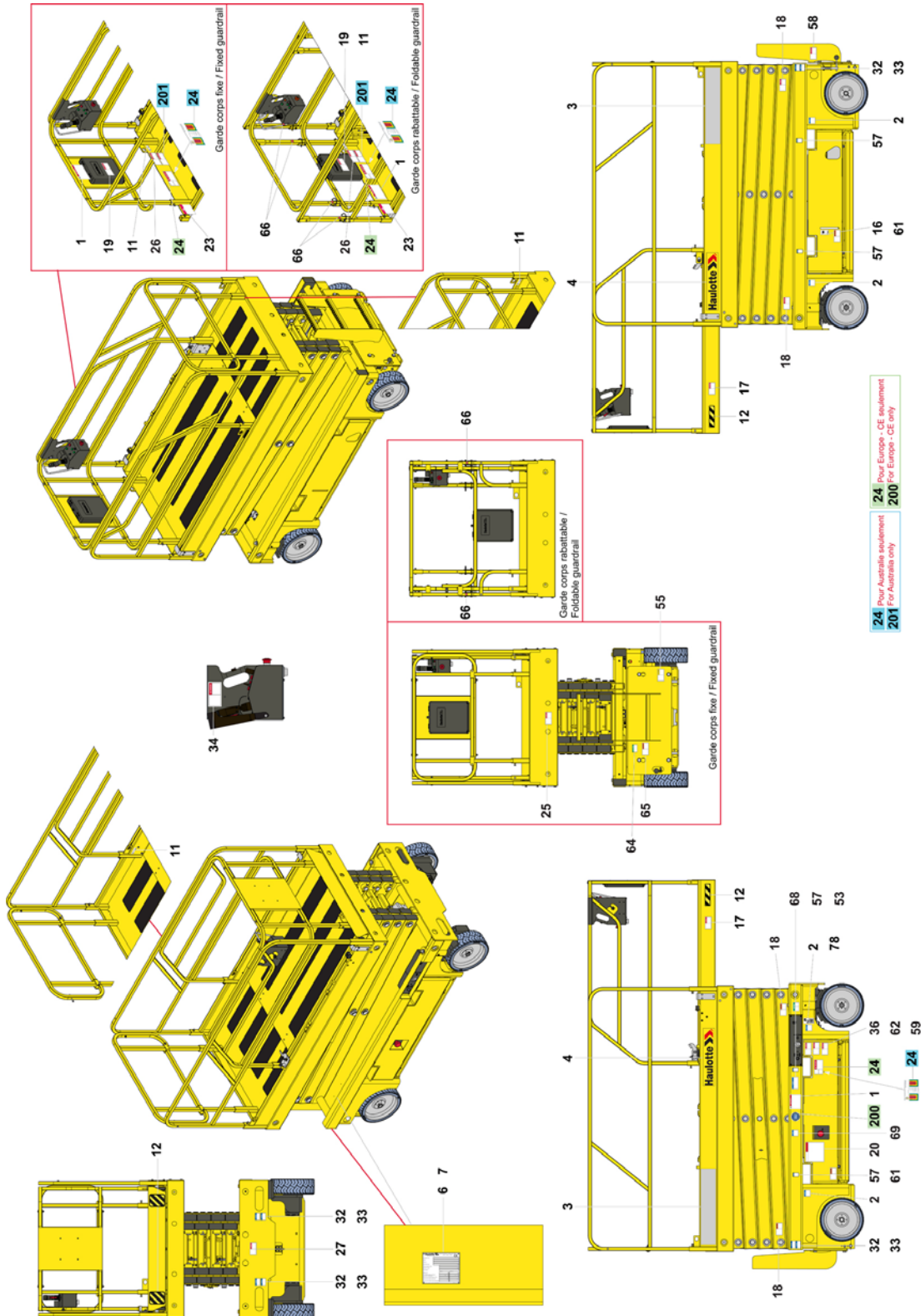

# B - Familiarization

## CE and AS standards - 4000326440 F - COMPACT 8 - COMPACT 10N

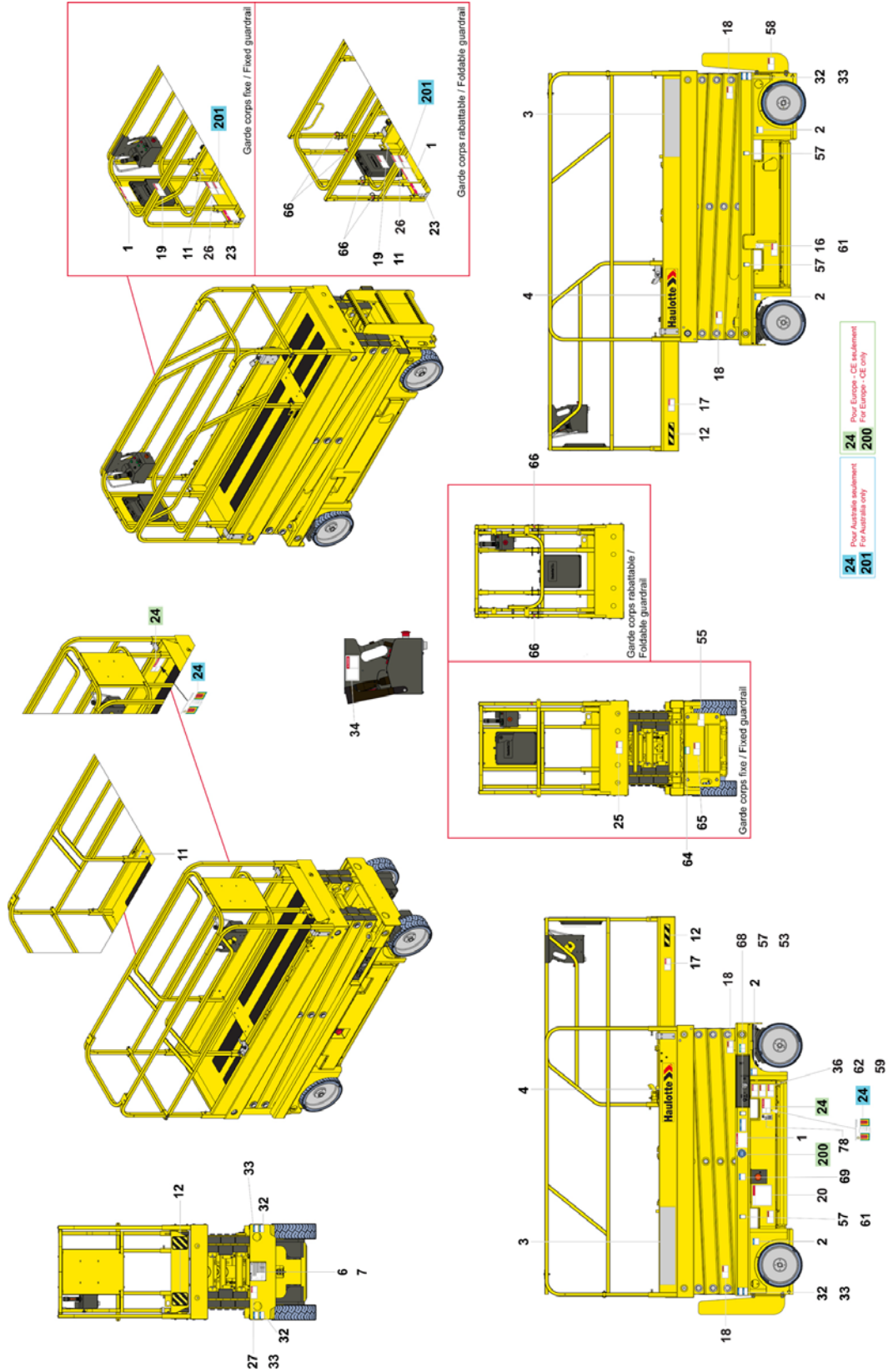

# B- Familiarization

## CE standard - COMPACT 8 - COMPACT 8W - COMPACT 10 - COMPACT 10N - COMPACT 12 - COMPACT 14

Marking	Color	Description	Quantity	
1	Red	Height of the floor and load	2	For COMPACT 8 : 4000701020 For COMPACT 8 Single load : 4000326090 For COMPACT 8W : 4000701040 For COMPACT 10 : 4000701050 For COMPACT 10N : 4000701030 For COMPACT 12 : 4000701060 For COMPACT 12 (Japan) : 4000502150 For COMPACT 14 : 4000701070
2	Blue	Maximum Pressure per Tire - Floor Loading	4	For COMPACT 8 : 4000814770 For COMPACT 8 Single load : 4000814820 For COMPACT 8W : 4000814830 For COMPACT 10 : 4000814840 For COMPACT 10N : 4000814850 For COMPACT 12 : 4000814860 For COMPACT 14 : 4000814870
3	Other	Commercial name - Bright machine	2	For COMPACT 8 and COMPACT 8 Single load : 3078145120 For COMPACT 8W : 3078145130 For COMPACT 10 : 3078145140 For COMPACT 10N : 3078150900 For COMPACT 12 : 3078145150 For COMPACT 14 : 307P227250
3	Other	Commercial name - Dark machine	2	For COMPACT 8 and COMPACT 8 Single load : 307P222270 For COMPACT 8W : 307P222840 For COMPACT 10 : 307P222240 For COMPACT 10N : 307P222280 For COMPACT 12 : 307P222250 For COMPACT 14 : 307P227240
4	Other	Decal HAULOTTE® - Bright machine	2	307P217080
4	Other	Decal HAULOTTE® - Dark machine	2	307P224740
4	Other	Decal HAULOTTE® - Red machine	2	307P220360
6	Other	Identification plate	1	4000700140
11	Other	Lanyard attachment points	C8 : 2 C8CU : 2 C8W : 3 C10 : 3 C10N : 2 C12 : 3 C14 : 3	307P216290
12	Other	Material risk - Yellow and black adhesive tape	2	4000424630
12	Other	Material risk - Yellow and black adhesive tape	2	4000421700
16	Other	Max and min oil level	1	307P221060
17	Red	Risk of crushing	2	4000244370
18	Red	Risk of crushing	4	4000024890
19	Red	Operation instructions	1	4000025140

# B- Familiarization

Marking	Color	Description	Quantity	
20	Red	Operation instructions	1	In english : 307P222740 In german : 307P222730 In chinese : 4000696620 In korean : 4000618590 In croatian : 4000360810 In danish : 307P222760 In Spanish : 307P222770 In estonian : 4000360870 In finnish : 307P222780 In french : 3078149030 In greek : 4000561810 In dutch : 307P222790 In hungarian : 4000360890 In italian : 307P222800 In japanese : 4000359830 In latvian : 4000359840 In lithuanian : 4000359850 In norwegian : 4000359900 In polish : 4000359860 In Portuguese : 307P222810 In romanian : 4000359870 In slovakian : 4000359880 In slovenian : 4000359890 In swedish : 307P222820
23	Red	Risk of crushing - Driving direction	1	3078145100
24	Red	Danger of electrocution	2	4000244350
25	Red	Risk of crushing - Closing drop rail	1	4000025080
26	Red	Danger of electrocution - Ground for welding	1	4000027100
27	Red	Verification of tilt operation	1	4000244380
32	Blue	Anchorage point - Traction	4	4000027310
33	Blue	Anchorage point - Lifting	4	4000027330
34	Red	Risk of electrocution - Water projection	1	4000025130
36	Red	Emergency lowering-Platform	1	4000244340
53	Green	Emergency lowering-T-handle	1	4000227200
55	Yellow	Risk of electrocution - Charger - 240 V	1	4000273940
57	Blue	Position of the lift truck forks	4	3078143830
58	Red	Battery compartment locking	1	4000310170
59	Orange	Scissors safety	1	4000027550
61	Orange	Risk of crushed feet	2	4000025060
62	Orange	Stop time during descent	1	4000271010
64	Green	Battery verification	1	4000274040
65	Orange	Hand crushing hazard - Battery	1	4000027440
66	Other	Danger	C10N / C10N.1 / C14 : 6	307P230010
68	Blue	Information-Transport height	1	For COMPACT 8 and Single load : 4000417380 For COMPACT 8W : 4000417400 For COMPACT 10 : 4000417410 For COMPACT 10N : 4000417390 For COMPACT 12 : 4000417420 For COMPACT 14 : 4000417430
69	Blue	Information-Battery isolation switch	1	4000420660
78	Other	QR Code (  <a href="https://www.e.technical-information.com">https://www.e.technical-information.com</a> )	1	4001089310
200	Other	Information - Explanation-"Made in Europe"	1	4000137690



# B- Familiarization

## AS standard - COMPACT 8 - COMPACT 8W - COMPACT 10 - COMPACT 10N - COMPACT 10N-1 - COMPACT 12 - COMPACT 14

Marking	Color	Description	Quantity	
1	Red	Height of the floor and load	2	For COMPACT 8 : 4000701020 For COMPACT 8W : 4000701040 For COMPACT 10 : 4000701050 For COMPACT 10N : 4000701030 For COMPACT 10N-1 : 4000467340 For COMPACT 12 : 4000701060 For COMPACT 14 : 4000701070
2	Blue	Maximum Pressure per Tire - Floor Loading	4	For COMPACT 8 : 4000814770 For COMPACT 8W : 4000814830 For COMPACT 10 : 4000814840 For COMPACT 10N : 4000814850 For COMPACT 10N-1 : 4000815270 For COMPACT 12 : 4000814860 For COMPACT 14 : 4000814870
3	Other	Commercial name - Bright machine	2	For COMPACT 8 : 3078145120 For COMPACT 8W : 3078145130 For COMPACT 10 : 3078145140 For COMPACT 10N and COMPACT 10N-1 : 3078150900 For COMPACT 12 : 3078145150 For COMPACT 14 : 307P227250
3	Other	Commercial name - Dark machine	2	For COMPACT 8 : 307P222270 For COMPACT 8W : 307P222840 For COMPACT 10 : 307P222240 For COMPACT 10N and COMPACT 10N-1 : 307P222280 For COMPACT 12 : 307P222250 For COMPACT 14 : 307P227240
4	Other	Decal HAULOTTE® - Bright machine	2	307P217080
4	Other	Decal HAULOTTE® - Dark machine	2	307P224740
4	Other	Decal HAULOTTE® - Red machine	2	307P220360
6	Other	Identification plate	1	4000700140
11	Other	Lanyard attachment points	C8 : 2 C8CU : 2 C8W : 3 C10 : 3 C10N : 2 C10N-1 : 2 C12 : 3 C14 : 3	307P216290
12	Other	Material risk - Yellow and black adhesive tape	2	4000424630
12	Other	Material risk - Yellow and black adhesive tape	2	4000421700
16	Other	Max and min oil level	1	307P221060
17	Red	Risk of crushing	2	4000244370
18	Red	Risk of crushed hands	4	4000024890
19	Red	Operation instructions	1	4000025140
20	Red	Operation instructions	1	307P222740
23	Red	Risk of crushing - Driving direction	1	3078145100
24	Red	Danger of electrocution	2	4000227500



# B- Familiarization

Marking	Color	Description	Quantity	
25	Red	Risk of crushing - Closing drop rail	1	4000025080
26	Red	Danger of electrocution - Ground for welding	1	4000027100
27	Red	Verification of tilt operation	1	4000244380
32	Blue	Anchorage point - Traction	4	4000027310
33	Blue	Anchorage point - Lifting	4	4000027330
34	Red	Risk of electrocution - Water projection	1	4000025130
36	Red	Emergency lowering-Platform	1	4000244340
53	Green	Emergency lowering-T-handle	1	4000227200
55	Yellow	Risk of electrocution - Charger - 240 V	1	4000307410
57	Blue	Position of the lift truck forks	4	3078143830
58	Red	Battery compartment locking	1	4000310170
59	Orange	Scissors safety	1	4000027550
61	Orange	Risk of crushed feet	2	4000025060
62	Orange	Stop time during descent	1	4000271010
64	Green	Battery verification	1	4000274040
65	Orange	Hand crushing hazard - Battery	1	4000027440
66	Other	Danger	C10N / C10N.1 / C14 : 6	307P230010
68	Blue	Information-Transport height	1	For COMPACT 8 : 4000417380 For COMPACT 8W : 4000417400 For COMPACT 10 : 4000417410 For COMPACT 10N and COMPACT 10N-1 : 4000417390 For COMPACT 12 : 4000417420 For COMPACT 14 : 4000417430
69	Blue	Information-Battery isolation switch	1	4000420660
78	Other	QR Code (  <a href="https://www.e.technical-information.com">https://www.e.technical-information.com</a> )	1	4001089310
201	Red	Information - Explanation-Wearing of a safety harness is essential	1	4000275670

**N.B.-:-COMPACT 10N-1 : ONLY FOR AUSTRALIA.**

# B - Familiarization

## EAC standard - 4000321810 G - COMPACT 8W - COMPACT 10 - COMPACT 12 - COMPACT 14

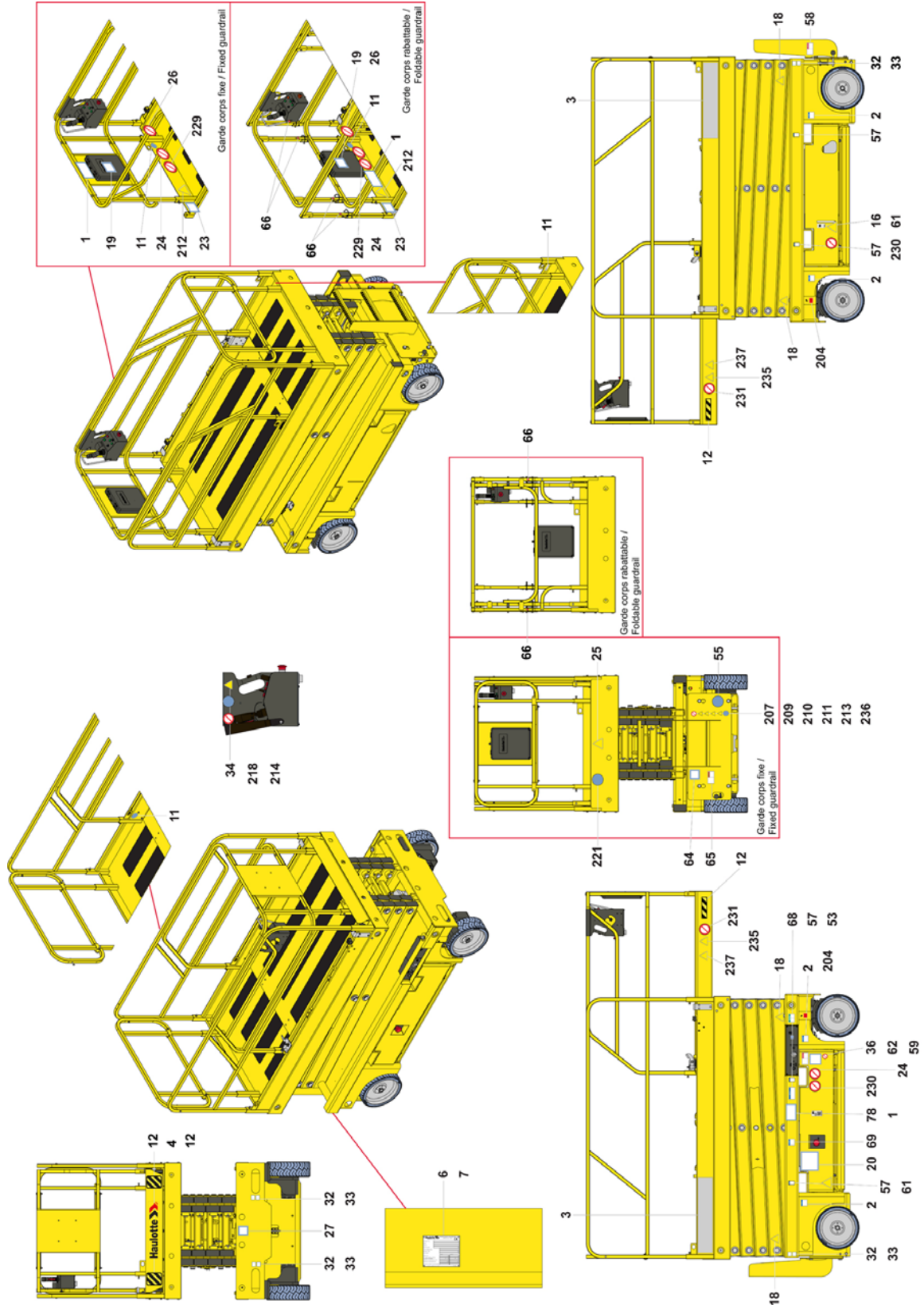



# B- Familiarization

## EAC standard - COMPACT 8 - COMPACT 8W - COMPACT 10 - COMPACT 10N - COMPACT 12 - COMPACT 14

Marking	Color	Description	Quantity	
1	Red	Height of the floor and load	2	For COMPACT 8 : 307P228400 For COMPACT 8 Single load : 307P223960 For COMPACT 8W : 4000044220 For COMPACT 10 : 4000043960 For COMPACT 10N : 307P227230 For COMPACT 12 : 4000043940 For COMPACT 14 : 4000015650
2	Blue	Maximum Pressure per Tire - Floor Loading	4	For COMPACT 8 : 4000814770 For COMPACT 8 Single load : 4000814820 For COMPACT 8W : 4000814830 For COMPACT 10 : 4000814840 For COMPACT 10N : 4000814850 For COMPACT 12 : 4000814860 For COMPACT 14 : 4000814870
3	Other	Commercial name - Bright machine	2	For COMPACT 8 : 3078145120 For COMPACT 8W : 3078145130 For COMPACT 10 : 3078145140 For COMPACT 10N : 3078150900 For COMPACT 12 : 3078145150 For COMPACT 14 : 307P227250
3	Other	Commercial name - Dark machine	2	For COMPACT 8 : 307P222270 For COMPACT 8W : 307P222840 For COMPACT 10 : 307P222240 For COMPACT 10N : 307P222280 For COMPACT 12 : 307P222250 For COMPACT 14 : 307P227240
4	Other	Decal HAULOTTE® - Bright machine	2	For Russia : 307P217080
4	Other	Decal HAULOTTE® - Dark machine	2	For Russia : 307P224740
4	Other	Decal HAULOTTE® - Red machine	2	For Russia : 307P220360
6	Other	Identification plate	1	For Russia : 4000388680 For Ukraine : 4000054150
11	Other	Lanyard attachment points	C8 : 2 C8W : 3 C10 : 3 C10N : 2 C12 : 3 C14 : 3	307P226710
12	Other	Material risk - Yellow and black adhesive tape	2	4000424630
12	Other	Material risk - Yellow and black adhesive tape	2	4000421700
16	Other	Max and min oil level	1	307P221060
18	Yellow	Risk of crushed hands	4	307P227660
19	Red	Operation instructions	1	For Russia : 307P227190 For Ukraine : 307P227840
20	Red	Operation instructions	1	For Russia : 4000359920 For Ukraine : 4000359910
23	Red	Risk of crushing - Driving direction	1	For Russia : 4000010890 For Ukraine : 4000011390
24	Red	Danger of electrocution	2	4000010920
25	Red	Risk of crushing - Closing drop rail	1	307P226950
26	Red	Danger of electrocution - Ground for welding	1	307P226970

# B- Familiarization

Marking	Color	Description	Quantity	
27	Red	Verification of tilt operation	1	For Russia : 307P227060 For Ukraine : 307P227870
32	Blue	Anchorage point - Traction	4	4000135970
33	Blue	Anchorage point - Lifting	4	4000135960
34	Red	Risk of electrocution - Water projection	1	307P226780
36	Red	Emergency lowering-Platform	1	4000244340
53	Green	Emergency lowering-T-handle	1	4000227200
55	Yellow	Risk of electrocution - Charger - 240 V	1	307P227520
57	Blue	Position of the lift truck forks	4	4000013830
58	Red	Battery compartment locking	1	4000310170
59	Orange	Scissors safety	1	4000270960
61	Orange	Risk of crushed feet	2	4000270970
62	Orange	Stop time during descent	1	For Russia : 4000011400 For Ukraine : 4000011430
64	Green	Battery verification	1	For Russia : 307P227180 For Ukraine : 307P227860
65	Orange	Hand crushing hazard - Battery	1	4000027440
66	Other	Danger	C10N / C14 : 6	307P230010
68	Blue	Information-Transport height	1	For COMPACT 8 : 4000417380 For COMPACT 8W : 4000417400 For COMPACT 10 : 4000417410 For COMPACT 10N : 4000417390 For COMPACT 12 : 4000417420 For COMPACT 14 : 4000417430
69	Blue	Information-Battery isolation switch	1	4000420660
78	Other	QR Code (  <a href="https://www.e.technical-information.com">https://www.e.technical-information.com</a> )	1	4001089310
204	Red	Lubrication point	2	307P219370
207	Red	Smoking forbidden	1	307P226760
209	Yellow	Battery danger	1	307P226790
210	Yellow	Fire Hazard	1	307P226800
211	Yellow	Electrical danger	1	307P226810
213	Yellow	Corrosion hazard	1	307P226830
214	Yellow	Danger unstable side	1	307P226930
218	Blue	Helmet compulsory	1	307P226680
221	Blue	Obligatory routing	1	307P227510
229	Red	Do not travel down slopes in high speed	1	307P226990
230	Red	No admittance to unauthorized persons	2	307P227560
231	Red	Do not park	2	4000010910
235	Yellow	Vertical crushing of the body	2	4000014270
236	Blue	Information - Explanation-Caution glasses	1	307P226670
237	Yellow	Lateral crushing of the body	2	307P227670



# B- Familiarization

ANSI and CSA standards - 4000312800 G - COMPACT 2047E - COMPACT 2747E -  
 COMPACT 3347E - COMPACT 3947E

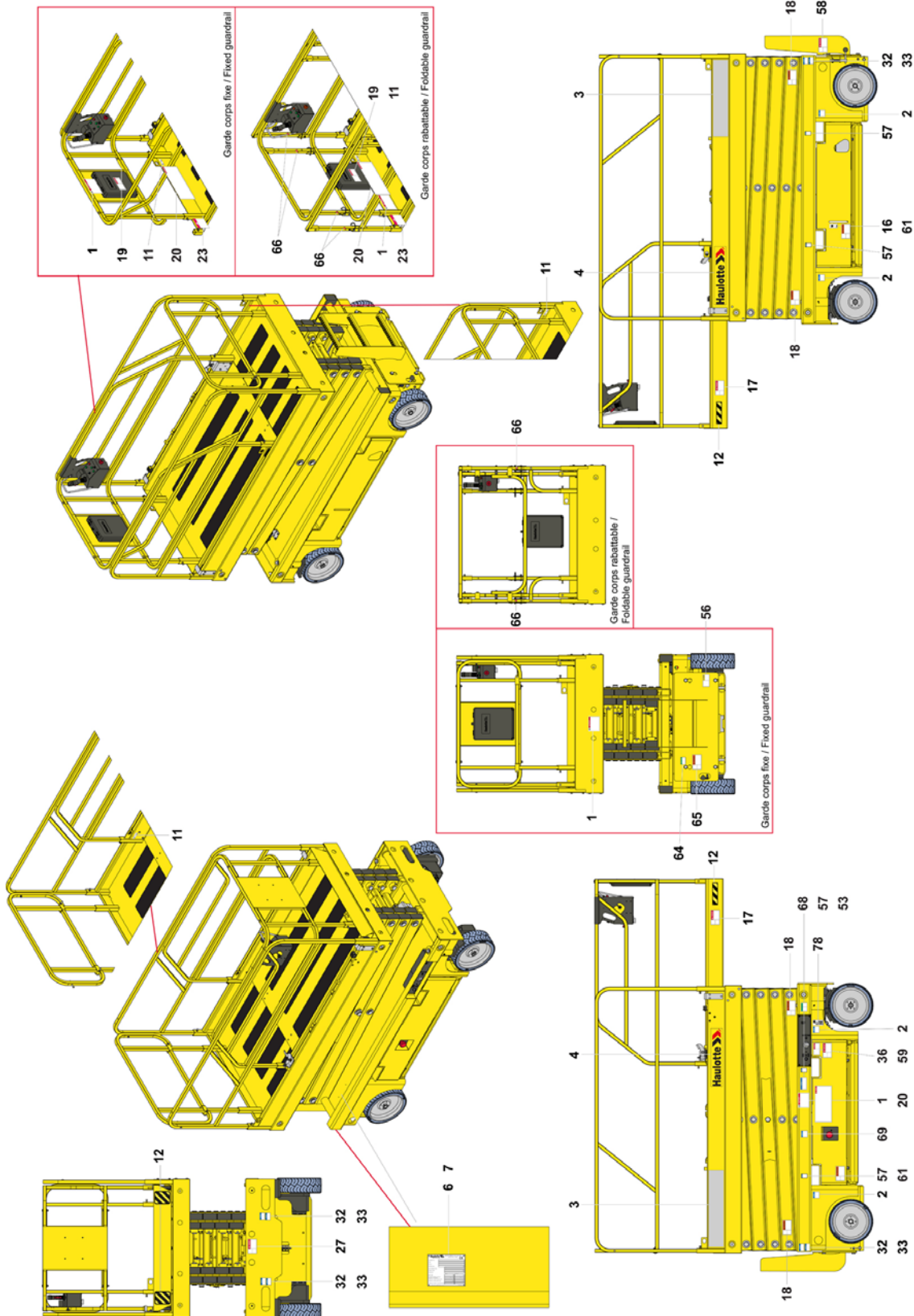

# B - Familiarization

## ANSI and CSA standards - 4000326460 G - COMPACT 2032E - COMPACT 2632E

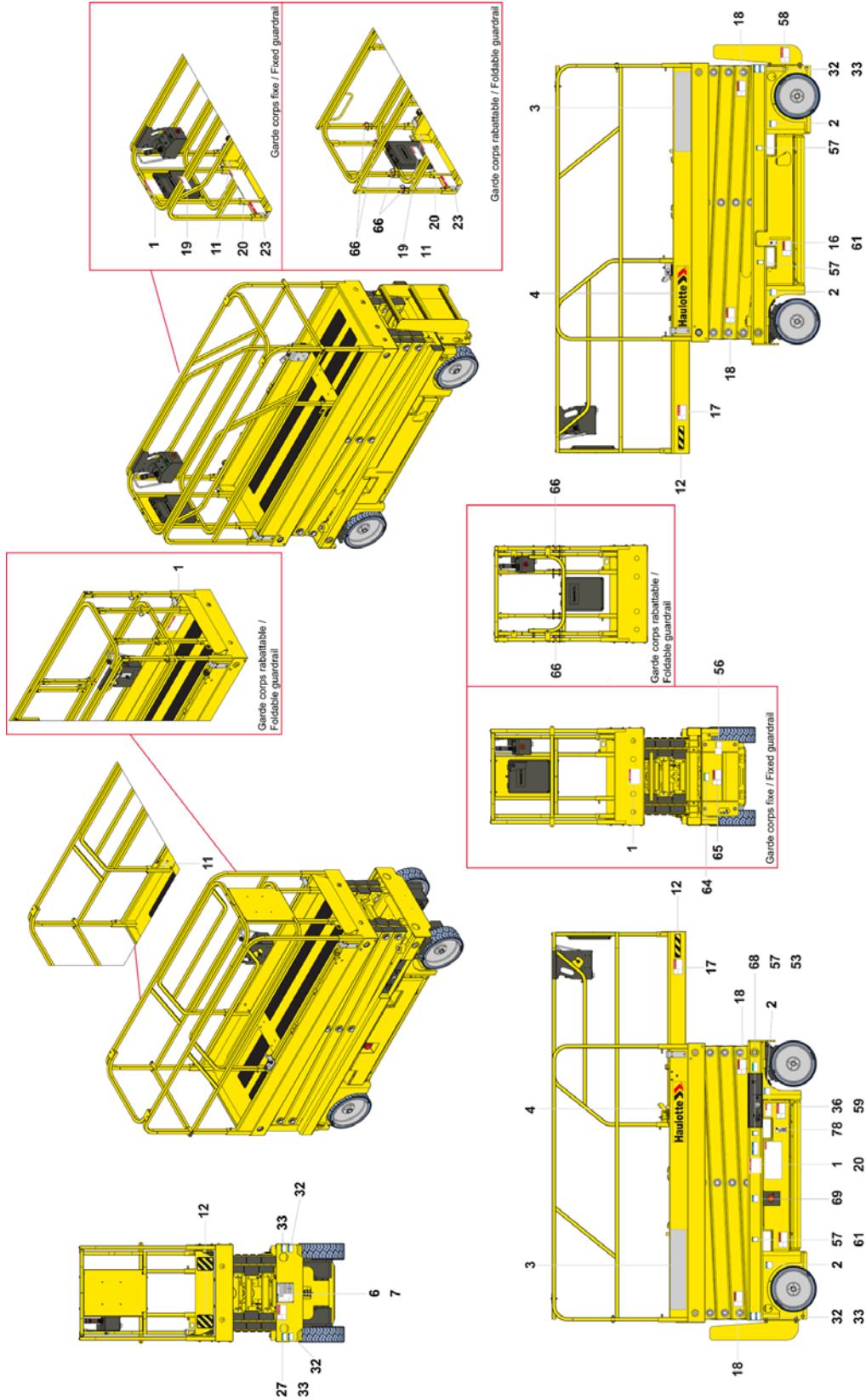

# B- Familiarization

## ANSI and CSA standards - COMPACT 2032E - COMPACT 2047E - COMPACT 2747E - COMPACT 2632E - COMPACT 3347E - COMPACT 3947E

Marking	Color	Description	Quantity	
1	Red	Height of the floor and load	3	For COMPACT 2032E : 4000701020 For COMPACT 2047E : 4000701040 For COMPACT 2747E : 4000701050 For COMPACT 2632E : 4000701030 For COMPACT 3347E : 4000701060 For COMPACT 3947E : 4000701070
2	Blue	Maximum Pressure per Tire - Floor Loading	4	For COMPACT 2032E : 4000814770 For COMPACT 2047E : 4000814830 For COMPACT 2747E : 4000814840 For COMPACT 2632E : 4000814850 For COMPACT 3347E : 4000814860 For COMPACT 3947E : 4000814870
3	Other	Commercial name - Bright machine	2	For COMPACT 2032E : 3078147040 For COMPACT 2047E : 3078147060 For COMPACT 2747E : 3078147070 For COMPACT 2632E : 3078151050 For COMPACT 3347E : 3078147080 For COMPACT 3947E : 307P229190
3	Other	Commercial name - Dark machine	2	For COMPACT 2032E : 307P224260 For COMPACT 2747E : 4000418270 For COMPACT 2632E : 4000418260 For COMPACT 3347E : 4000418250 For COMPACT 3947E : 4000206820
4	Other	Decal HAULOTTE® - Bright machine	2	307P217080
4	Other	Decal HAULOTTE® - Dark machine	2	307P224740
4	Other	Decal HAULOTTE® - Red machine	2	307P220360
6	Other	Identification plate	1	4000700150
11	Other	Lanyard attachment points	C2032E : 2 C2047E : 3 C2747E : 3 C2632E : 2 C3347E : 3 C3947E : 3	307P216290
12	Other	Material risk - Yellow and black adhesive tape	2	4000424630
12	Other	Material risk - Yellow and black adhesive tape	2	4000421700
16	Other	Max and min oil level	1	307P221060
17	Red	Risk of crushing	2	In english : 4000130190 In french : 4000130200 In spanish : 4000130210
18	Yellow	Risk of crushed hands	4	In english : 4000024770 In french : 4000067710 In spanish : 4000086490
19	Red	Operation instructions	1	4000025140
20	Red	Operation instructions	2	In english : 4000243670 In french : 4000243680 In spanish : 4000243690
27	Red	Verification of tilt operation	1	In english : 4000130300 In french : 4000130310 In spanish : 4000130320
32	Blue	Anchorage point - Traction	4	4000027310



# B- Familiarization

Marking	Color	Description	Quantity	
33	Blue	Anchorage point - Lifting	4	4000027330
36	Red	Emergency lowering-Platform	1	4000244340
53	Green	Emergency lowering-T-handle	1	4000227200
56	Yellow	Risk of electrocution - Charger - 110 V	1	4000419150
57	Blue	Position of the lift truck forks	4	3078143830
58	Red	Battery compartment locking	1	4000310170
59	Orange	Scissors safety	1	In english : 4000024850 In french : 4000068070 In spanish : 4000086500
61	Orange	Risk of crushed feet	2	In english : 4000024780 In french : 4000067700 In spanish : 4000086480
64	Green	Battery verification	1	4000274040
65	Orange	Hand crushing hazard - Battery	1	In english : 4000025030 In french : 4000068120 In spanish : 4000086550
66	Other	Danger	C2632E / C3947E : 6	307P230010
68	Blue	Information-Transport height	1	For COMPACT 2032E : 4000417380 For COMPACT 2047E : 4000417400 For COMPACT 2747E : 4000417410 For COMPACT 2632E : 4000417390 For COMPACT 3347E : 4000417420 For COMPACT 3947E : 4000417430
69	Blue	Information-Battery isolation switch	1	4000420660
78	Other	QR Code (  <a href="https://www.e.technical-information.com">https://www.e.technical-information.com</a> )	1	4001089310



# C - Pre-operation inspection

## 1 - Recommendations

The owner, the site manager, the supervisor and the operator are all responsible to ensure the machine is fit for the work it is to perform; i.e. that the machine is suitable to carry out the work in complete safety and in compliance with this Operator's Manual. All managers who are responsible for persons operating the machine must be familiar with the local regulations currently applicable in the country of use and ensure that they are adhered to.

Before using the machine, read the previous chapters in this manual. Ensure that you have understood the following points :

- Safety precautions.
- Operator's responsibilities.
- Conditions and the operating principles of the machine.

## 2 - Working area assessment

Before carrying out any operations, ensure that the machine corresponds to the work to be done and the working environment :

- Carry out a thorough inspection of the site to identify any potential risks within the work zone.
- Take the necessary precautions to avoid collisions with other machinery within the work zone.

Ensure that :

- The weather conditions (wind, rain, etc.) allowing the machine to be used.
- The ground withstands the weight of the machine and has not been affected by the poor weather conditions.
- Check that the authorisations to work with the machine on the site in question have been obtained (.g. chemical product factories).
- Define a rescue plan for all the risks, including the risk of falls and crushing.

# C - Pre-operation inspection

## 3 - Inspection and Functional test

### 3.1 - DAILY INSPECTION

Each day before the beginning of a new work session and with each change of operator, the machine must be subjected to a visual inspection and a complete functional test.



- **Never use a defective or a malfunctioning aerial work platform.**
- **If any item on the check list is marked "No" during the inspection; machine must be tagged and placed out of service.**
- **Do not operate the machine until all identified items are corrected and it has been declared safe for operation.**

In case of loose fasteners, refer to torque table value in maintenance book.

In case of leaks, replace the damaged part before use.

In case of structural part deformation (cracks, broken weld, paint chips) replace the part before use.



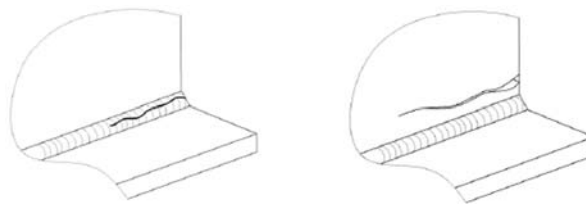





#### Sample of broken welds



We recommend these forms to be completed daily and stored to assist with your maintenance schedule.

Each action is depicted in the daily inspection sheet using the following symbols.













Use the detailed program below.

	Oil change		Lubrication-Lubrication		Tightening
	Levelling		Systematic replacement		Functional adjustments / Checks / Cleaning
	Visual inspection		To check by test		

Serial number :	Model :
Hours of operation :	
HAULOTTE Services® contract reference :	
Intervention record number :	Signature :
Date :	
Name :	

# C - Pre-operation inspection

## Electric scissor lifts

	Page or associated procedure	Daily	OK	NOK	Corrected	Comments
<b>Chassis assembly : Wheel, reducer, steering, wheel pivot</b>						
Check state of tires/tyres and inflations						
Clean the pads slide						
<b>Batteries</b>						
Check the battery level						
Check the condition of the battery						
Check the operation of the lock on the engine casing						
<b>Hydraulic : oils, filters and hoses</b>						
Check the hydraulic oil level (Top up the oil if necessary ; Machine stowed)						
Check the clogging indicator on the hydraulic pressure filter (change if clogged)						
Check the hoses, blocks and pumps, fittings, cylinders and the tank for the absence of leaks, deformations and damage						
<b>Platform</b>						
Test the automatic closure and locking of access basket						
Check that the harness anchor points are not cracked or damaged						
Clean the platform extension						
Check the quick ties and the good location of the guardrail						

A

B

C

D

E

F

















G

H

I

# C - Pre-operation inspection

## Electric scissor lifts

	Page or associated procedure	Daily	OK	NOK	Corrected	Comments
<b>General</b>						
Check for the presence, cleanliness and readability of the manufacturer's plates, security labels, user manual and maintenance manual						
Check the cleanliness and readability of the control box						
Test the opening and closure of covers (chassis, turntable, upper control box)						
Check the condition of electrical harnesses, cables and connectors						
Check for the absence of abnormal noise and jerky movements						
Check for the absence of visible deterioration and damage						
Check for the absence of cracks, broken welds and chipped paintwork on the structure						
Check for the absence of missing or loose screws and bolts						
Check for the absence of deformation, cracking and breakage of axis stops, bushing and axes						
Check for the absence of foreign bodies in joints and sliding parts						
<b>Safety devices</b>						
Test the operation of the upper and lower control boxes: manipulators, switches, buttons, horn, emergency stops, screens and lights						
Check the absence of visual and audible alarms						
Test the operation of the tilt system						
Test the operation of the emergency lowering system						
Test the operation of the load control system - Calibrate if necessary						

# C - Pre-operation inspection

## 4 - Safety functional checks

To protect the user and the machine, safety systems prevent the movement of the machine beyond its operating limits. These safety systems when activated immobilize the machine and prevent further movement.

The operator must be familiar with this technology and understand that is not a malfunction but an indication that the machine has reached an operation limit.

Aerial Work platforms are equipped with two control boxes which allow operators to safely use the machine. An auxiliary device (T-handle) is available on the chassis to assist with the emergency lowering of the machine. Each control box is equipped with an E-Stop button, which cuts all movements when pushed in.

The following checks describe the operation of the machine and the specific controls required.

The speed selector buttons at the ground control box and the platform control box act as the enable switch.

For the location and description of these controls :  refer to section B 3.2 and D 2 - Ground control box and B 3.3 and D 3 - Platform control box.

### 4.1 - E-STOP BUTTON CHECK

#### Ground control box E-stop button

Step	Action
1	Pull the E-stop switch- buttons (cut-off) 144, 46
2	Switch the machine on 92.
3	Turn the key of the control box activation switch ( 92 ) to the right to energize the ground control box. The indicators light up.
4	Push the E-stop switch- push button (cut-off) 144. The indicators go out.

#### Platform control box E-stop button

Step	Action
1	Pull the E-stop switch- buttons (cut-off) 144, 46
2	Switch the machine on 92.
3	Turn the key on the control box activation selector switch ( 92 ) to the left to energize the platform control box. The indicators light up.
4	Push the E-stop switch- push button (cut-off) 46. The indicators go out.

# C - Pre-operation inspection

## 4.2 - ACTIVATION OF CONTROLS

The enable switch must be activated to allow any movement.

The "Enable Switch" system depends on the machine configuration and will consist of one of the following :

- Enable trigger on platform control joystick.
- Foot pedal (enable switch) in the platform.
- Enable switch at ground and platform boxes.

## 4.3 - FAULT DETECTOR

***N.B.-:THE PRESENCE OF THIS DEVICE DEPENDS ON THE MACHINE CONFIGURATION.***

The fault indicator LED flashes to indicate a malfunction.

The machine switches to downgraded mode.

Certain movements can be limited or forbidden to preserve the operator's safety.

### 4.3.1 - Buzzers test

#### From the ground control box

Step	Action
1	Pull the E-Stop buttons ( 144 ) at ground control box and ( 46 ) on the platform control box
2	Turn the control box activation selector key ( 92 ) to the left or right to activate a control box. An audible signal (beep) sounds.

## 4.4 - OVERLOAD SENSING SYSTEM

The overload limitation system activates if the heights defined in the "Transport position maximum height" table are exceeded (  Section C 4.6 - Travel speed limitation).

If the platform load exceeds the maximum allowed load, no movement is possible from the 2 control boxes.

At ground and platform control boxes a buzzer sounds and an indicator light warns the operator.

To return the machine to normal operation remove weight from the platform until the load is below the maximum allowed load.

Daily check that the LED's illuminate when the machine is switched on :

- Verify that the Overload system is active : Refer to Indicators ( 6 ) at ground and ( 30 ) at platform.
- Verify that the buzzers are functioning : Refer to Buzzers test

A periodic inspection of this device must be performed according to the recommendation in Maintenance Schedule.



# C - Pre-operation inspection

## 4.5 - SLOPE WARNING DEVICE

The tilt sensor alerts the operator when it reaches the maximum permissible tilt. The tilt limitation system activates if the heights defined in the "Transport position maximum height" table are exceeded (  Section C 4.6 - Travel speed limitation).

Drive and elevation controls are cut if this situation lasts longer than 1 or 2 s.

To restore the drive function, only movements allowing the machine to be stowed are permitted :

- Platform lowered.

From each control box, a buzzer alerts the operator that the machine is not folded/stowed and is positioned on a slope exceeding the slope allowed. 

***N.B.-:-THE SLOPE SENSOR IS ONLY ACTIVE WHEN THE PLATFORM IS NOT IN THE STOWED POSITION.***



When the unfolded machine is on a slope greater than the rated slope, out of the stowed position, DRIVE and LIFT functions are disabled.

All functions speeds are reduced.

In this case, fully lower the platform and reposition the machine on level ground before raising the platform again.

***N.B.-:-DEPENDING ON YOUR MACHINE CONFIGURATION, OUTSIDE ASSISTANCE MAY BE NECESSARY IN ORDER TO CARRY OUT THIS OPERATION.***

### To check the tilt sensor at ground control box

Step	Action
1	Pull the E-stop push-buttons on the platform and ground control boxes (144, 46).
2	Switch on the machine from the ground control box (92).
3	For COMPACT 8W - COMPACT 2047E - COMPACT 14 - COMPACT 3947E only : Place the machine in maintenance configuration (  Section B 3.2 - Maintenance support).
4	Locate the tilt sensor next to the ground control box.
5	Manually tilt and maintain the tilt sensor towards the front for a few seconds (  Section B 3.1 - Layout).
6	The audible beep sounds.
7	For machines fitted with : The slope sensor prevents lifting and driving movements.

# C - Pre-operation inspection

## 4.6 - TRAVEL SPEED LIMITATION

The machine has a selector of 2 driving speeds - low and high.

All driving speeds are authorised when the machine is folded, (machine in transport position).

The maximum travelling speeds are reduced when the following lifting height is reached :

Machine	Transport configuration limit height	
	Mètre	Feet
COMPACT 8-COMPACT 2032E	1,60	5 ft 3 in
COMPACT 8W-COMPACT 2047E	1,75	5 ft 9 in
COMPACT 10N-COMPACT 2632E	1,55	5 ft 1 in
COMPACT 10-COMPACT 2747E	1,80	5 ft 11 in
COMPACT 12-COMPACT 3747E	1,85	6 ft 1 in
COMPACT 14-COMPACT 3947E	2,45	8 ft 0 in

When not in the above-described transport position, the low speed is engaged automatically.

The electronic variable speed unit controls movement and driving speed.

It receives information from the control joystick concerning the movements to be performed.

It also manages the safety systems status.

Poor knowledge of the characteristics and operation of the machine can lead the operator to think that a normal safety operation is a malfunction.

## 4.7 - ELECTRONIC VARIABLE SPEED DRIVE



The machines are equipped with 2 electronic variable speed regulators configured for each function and manages the required power needed for each motor.



**Do not interchange the speed controllers/regulators between machines even if they are the same model.**

# C - Pre-operation inspection

## 4.8 - POTHOLE PROTECTION SYSTEM

A system of protection against the holes on road is spread automatically when the platform is raised above values quoted in the table  Section C 4.2 - Drive speed. Only micro-speed is possible in this position. If the pothole protection are not extended, micro-speed and platform elevation are automatically cut. As soon as the platform is below values quoted in the table  Section C 4.2 - Drive speed and that control into large and low speed are engaged, the anti-tipping over devices return automatically.



The lifting height depends on the model of the machine. Refer to  Section C 4.2 - Drive speed.

## 4.9 - ON-BOARD CHARGER

The on-board charger is used to charge the semi-drive batteries.

Battery charging starts as soon as it is connected via the mains supply.

The ( 93 ) indicator indicates charge status :

- Green LED : Battery charged 100 %.
- Yellow LED : Battery charged 80 %.
- Red LED : Battery in initial charging phase.

If a fault occurs, the indicator flashes in different colours, depending on the type of fault (See machine maintenance book). The audible beep sounds.

A

B

C

D

E

F

G

H

I

# C - Pre-operation inspection

## 4.10 - BATTERY DISCHARGE INDICATOR-HOUR METER

The battery charger-hour recorder combines 3 functions :

- Battery charger status
- Hour meter
- Alarm codes



Battery charged : The green diodes are on.

The battery discharges : The diodes go out one after the other.

Battery discharged : The red LED lights up. Elevation is cut and driving is still possible.

### 4.10.1 - Hour meter

It totals up :

- The machine operating hours.

### 4.10.2 - Alarm codes

The red LED flashes, an alarm code is displayed.

The machine has a fault (refer to the error code indicated).

# D - Operation instructions

## 1 - Operation

### 1.1 - INTRODUCTION

Only trained and authorized personnel shall be permitted to operate this aerial work platform.

*Prior to operation :*

- Read, understand and obey all instructions and safety precautions in this manual and attached to the aerial work platform.
- Read, understand and obey all local regulations.
- Become familiar with the proper use of all controls and emergency systems.

A

B

C

**D**

E

F

G

H

I

# D - Operation instructions

## 1.2 - OPERATION FROM THE GROUND CONTROL BOX

- Turning "ON" and "OFF" of the machine is performed with selector key switch (92).
- Activation of a desired control box is achieved by turning the control box energizing selector switch ( 92 ) to the desired position.
- The ground control box is energized and is active ONLY when :
  - The emergency stop on the ground control box is not pushed in.
  - The machine is switched on.
  - Ground control box is selected.
- An E-stop button at each control box stops all movements when pressed in (deactivated).

***N.B.-:-AN E-STOP BUTTON PRESSED IN DOES NOT TURN OFF THE MAIN POWER SUPPLY TO THE MACHINE.***

- An Enable Switch ( 9 ) provided must be activated and maintained to authorize one or more function movements. If Enable Switch ( 9 ) is kept engaged without selecting a function movement for more than 8 s; Enable Switch is automatically de-activated.
- The release of "Enable switch" ( 9 ) while performing a movement stops all the movements. The stop of movements is progressive. If the Enable Switch system is re-pressed, the movement doesn't restart. It could restart only when the selected function switch/joystick is released to neutral position.
- All switches and joystick operating a movement, return automatically to neutral when released.
- The ground control box is designed for maintenance and emergency rescue operations only. Refer to  Section D 4.2 To rescue operator in platform.
- The status of the switches is tested automatically when the machine is switched on, and checked at every starting. A switch will be active only after it has been detected to be in neutral position. The following switches are not controlled :
  - Beacon light (if fitted)

A buzzer beeps in the following conditions :

- Overload (if fitted).
- Machine out of stowed position and on a slope greater than allowable slope.
- Movements option.
- Indicators : All indicators are checked after powering on the machine

# D - Operation instructions

## 1.3 - OPERATION FROM THE PLATFORM CONTROL BOX

- The platform control box can only be used if :
  - The E-stop buttons on both ground and platform control boxes are not pressed in.
  - Machine switched on at ground control box.
  - Platform control box selected from ground control box.
- A faulty joystick is not taken into account to control a movement. If this fault disappears, the movement is authorised again.
- An E-Stop button is present at each control box. When pushed in, it stops all functions movements.
- An Enable switch ( 123 ) or Foot Switch in the basket ( 245 ) is present and should be activated to authorize one or more function movements. If the Enable Switch is kept active for more than 8 seconds without selecting a function movement, then movement is disallowed. The enable switch must be released (reset) before movement can occur.
- The release of "Enable switch" ( 123 ) or Foot pedal switch in the basket ( 245 ) while performing a movement stops all the movements. The stop of movements is progressive. It could restart only when the selected function switch/joystick is released to neutral position.
- All switches and joystick operating a movement, return automatically to neutral when released.
- The status of the switches and joysticks is tested automatically when the machine is switched on. A switch or joystick will be active only after it has been detected in neutral position.

A buzzer beeps in the following conditions :

- Overload.
- Machine elevated on a slope greater than the rated slope.
- Indicators - All the indicators are tested
  - When the machine is switched on.



**While driving on a slope :**

- Always orientate the machine in the direction of the slope.
- Stow the machine completely.
- Do not travel down slopes in high speed.
- Do not drive fast in narrow or cluttered areas. Keep speed under control while making turns or sharp bends.

# D- Operation instructions

## 2 - Ground control box

### 2.1 - TO START AND STOP THE MACHINE

- Pull the E-stop button 144.
- Switch the machine on 92.
- Turn the key of the control box activation switch ( 92 ) to the right to energize the ground control box.

To shut-down the machine from the ground control box :

- Turn the control box activation selector ( 92 ) key to the center.
- Push in the E-stop switch- push button (cut-off)( 144 ).



### 2.2 - MOVEMENT CONTROL



Even at low movement speeds, use the controls with caution.

***N.B.-:-RELEASING THE ENABLE SWITCH WILL STOP ALL MOVEMENTS.***

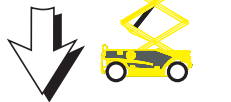
#### Ground box controls (emergency station)

Command	Action
Platform raising / lowering	 <p>Push the platform raising / lowering selector ( 106 ) upwards to raise the platform.</p>
	 <p>Press the platform raising / lowering selector ( 106 ) downwards to lower the platform.</p>
Emergency lowering / Emergency platform lowering halted	 <p>Pull the T-handle ( 107 ) to lower the platform.</p>
	<p>Release the T-handle ( 107 ) to stop platform lowering.</p>



Once rescue operations are complete, write an incident report.

***N.B.-:-RELEASING THE ( 92 ) KEY OR ( 106 ) SELECTOR STOPS MOVEMENT.***



# D - Operation instructions

***N.B.:-PULLING ON TO THE T-HANDLE, IMMEDIATELY ACTIVATES THE EMERGENCY LOWERING OF THE PLATFORM.***



**ALWAYS** keep personnel and obstructions clear of the aerial work platform that might block the lowering.

## 2.3 - ADDITIONAL CONTROLS FROM THE GROUND CONTROL BOX

For the machines equipped with beacon light :

- Push the flashing light switch ( 105 ) upwards to switch on the flashing light.
- Push the flashing light switch ( 105 ) downwards to switch off the flashing light.

A

B

C

**D**

E

F

G

H

I

# D - Operation instructions

## 3 - Platform control box

### 3.1 - TO START AND STOP THE MACHINE

To start the machine :

At the ground control box :

- The E-stop button on the ground control box must be in ON position (pulled out / activated).
- Turn the key on the control box activation selector switch ( 92 ) to the left to energize the platform control box.

At the platform control box :

- Pull the E-stop button (46).

To stop the machine :

- Push in the E-stop button (46).





### 3.2 - DRIVE AND STEER CONTROL

#### 3.2.1 - Control box - Standard



Activate the controls and the Enable Switch simultaneously to perform the various movements.

#### Drive and steer control

Command	Action
Driving <sup>1</sup> .	 Push the movement joystick ( 108 ) forwards to move the machine forwards.
	 Push the movement joystick ( 108 ) forwards to reverse the machine.
Front-axle steering	 Push the front-axle steering selector thumb switch ( 108 ) to the right to steer to the right.
	 Push the front-axle steering selector thumb switch ( 108 ) to the left to steer to the left.

1. When the platform is raised above 1,50 m(4 ft11 in), only micro-speed is possible

**N.B.:-THE RELEASE OF THE SELECTORS AND (OR) JOYSTICKS CAUSES ALL MOVEMENT TO STOP.**

# D - Operation instructions

## 3.3 - MOVEMENT CONTROL

### 3.3.1 - Control box - Standard

To operate raising/lowering function, move 3 position selector switch ( 112 ) to the left. The elevation / lowering selection indicator ( 110 ) lights up. Simultaneously operate joystick ( 108 ) with joystick trigger (Enable switch ( 123 )) pressed in and maintained.

**N.B.:-FOR JAPAN ONLY - BOTH THE ENABLE SWITCH ( 123 ) AND FOOT PEDAL ( C42 ) MUST BE PRESSED TO ACTIVATE A FUNCTION.**

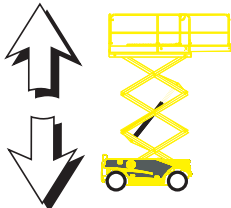
Command	Action
Platform raising / lowering 	Push the movement joystick ( 108 ) forwards to raise the platform. Push the movement joystick ( 108 ) backwards to lower the platform *.

\* When the platform is lowered to a height of 1,50 m(4 ft11 in) from the ground; a time delay is automatically activated for a few seconds, before any further lowering of the platform can commence. This is to avoid any risk of crushing. The alarm sounds.

## 3.4 - ADDITIONAL CONTROLS

- Horn : Push the horn selector ( 43 ) to the right to sound the horn. The horn stops when the selector switch is released.

A

B

C

D

E

F

G

H

I

# D - Operation instructions

## 4 - Rescue and emergency procedures

### 4.1 - IN CASE OF POWER LOSS

In case of loss of the main power source, lower the basket (or platform) using the T-handle on the chassis.

In an emergency, if the operator has to exit the platform while it is elevated, the transfer of the operator must respect the following recommendations. :

- Exit onto a sturdy and safe structure.
- The occupant(s) must ensure that 2 lanyards are used for security/safety. One must be attached to the designated anchorage point on platform the occupant(s) is in and the other attached to the structure intended to get on.
- Occupant(s) must exit the current platform through the normal access.

***N.B.-:-DO NOT DETACH THE LANYARD FROM THE CURRENT PLATFORM IF THE TRANSFER TO THE NEW STRUCTURE POSES ANY DANGER OR UNTIL THE TRANSFER IS SAFELY COMPLETED. DO NOT ATTEMPT TO CLIMB DOWN FROM THE PLATFORM. WAIT FOR ASSISTANCE TO LEAVE THE CRADLE SAFELY.***

### 4.2 - TO RESCUE OPERATOR IN PLATFORM

In a situation where an operator located in the platform needs to be rescued (for example in case of illness, injury or trapped against a structure making the control box inaccessible), the rescue personnel at ground level needs to obtain rapid and direct access to operating functions.

HAULOTTE® has implemented a control system for safely lowering the operator to the ground in the event of an emergency to enable him to receive the necessary treatment.

1. Turn the key of the control box activation switch ( 92 ) to the right to energize the ground control box. The platform box controls are de-energized.
2. Lower the platform from the ground control box.
3. Lower the platform using the selector ( 106 ) while holding the key ( 92 ).
4. Release it to halt lowering.

If a safety systems do not allow normal movement from the ground control box, lower the basket (or platform) using the T-handle (Overriding System) ( 107 ) on the ground control box.



**Once rescue operations are complete, write an incident report.**

# D - Operation instructions

## 5 - Transportation

### 5.1 - PUTTING IN TRANSPORT POSITION

During loading, ensure that :

- The loading ramp can support the machine weight.
- The loading ramp is correctly attached to transport vehicle.
- The loading ramp has sufficient grip surface.
- The transport vehicle must be parked on a level surface and must be secured to prevent rolling away while machine is being loaded or unloaded.

To climb the slope, move progressively the drive joystick ( 108 ).

If the slope is too steep, use a winch in addition to traction.

Do not place yourself below or too close to the machine during loading.

The machine must be completely in the stowed configuration :

- Check the platform is completely empty.
- Platform extension must be retracted in the locked position.
- Drive the machine onto the truck bed.
- Secure the machine to the tie down points provided (See picture).



**The manual extension (if fitted) must be retracted and locked during transport or towing.**

A

B

C

**D**

E

F

G

H

I

# D - Operation instructions

## 5.2 - MACHINE LAYOUT — COMPACT 8/ 8W / 10N / 10 / COMPACT 12 / COMPACT 14

**COMPACT 8 - COMPACT 2032E - COMPACT 8W - COMPACT 2047E -  
 COMPACT 10N - COMPACT 2632E - COMPACT 10 - COMPACT 2747E -  
 COMPACT 12 - COMPACT 3347E - COMPACT 14 - COMPACT 3947E**

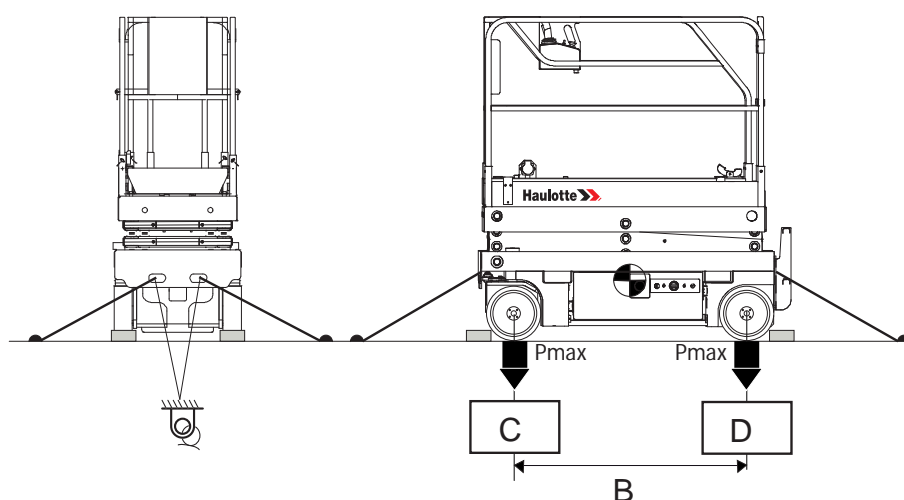

**Loading characteristics**

Marking	Description	COMPACT 8 - COMPACT 2032E	COMPACT 8W - COMPACT 2047E)
B	Lateral distance between the wheels <sup>1.</sup>	1,86 m(6 ft1 in)	1,86 m(6 ft1 in)
C	Front wheel ground pressure <sup>(1.)</sup>	19,2 kg/cm <sup>2</sup> (39400 lb/ft <sup>2</sup> )	20 kg/cm <sup>2</sup> (41030 lb/ft <sup>2</sup> )
D	Rear wheel ground pressure <sup>(1.)</sup>	19,2 kg/cm <sup>2</sup> (39400 lb/ft <sup>2</sup> )	20 kg/cm <sup>2</sup> (41030 lb/ft <sup>2</sup> )
	Anchorage point		

1. Check the technical data in the technical characteristics

**Loading characteristics**

Marking	Description	COMPACT 8 - COMPACT 2032E) Single load (Option)
B	Lateral distance between the wheels <sup>1.</sup>	1,86 m(6 ft1 in)
C	Front wheel ground pressure <sup>(1.)</sup>	19,4 kg/cm <sup>2</sup> (39750 lb/ft <sup>2</sup> )
D	Rear wheel ground pressure <sup>(1.)</sup>	19,4 kg/cm <sup>2</sup> (39750 lb/ft <sup>2</sup> )
	Anchorage point	

1. Check the technical data in the technical characteristics

# D - Operation instructions

## Loading characteristics

Marking	Description	COMPACT 10N - COMPACT 2632E	COMPACT 10 - COMPACT 2747E
B	Lateral distance between the wheels <sup>1.</sup>	1,86 m(6 ft1 in)	1,86 m(6 ft1 in)
C	Front wheel ground pressure <sup>(1.)</sup>	20,2 kg/cm <sup>2</sup> (41340 lb/ft <sup>2</sup> )	21,2 kg/cm <sup>2</sup> (43320 lb/ft <sup>2</sup> )
D	Rear wheel ground pressure <sup>(1.)</sup>	20,2 kg/cm <sup>2</sup> (41340 lb/ft <sup>2</sup> )	21,2 kg/cm <sup>2</sup> (43320 lb/ft <sup>2</sup> )
	Anchorage point		

1. Check the technical data in the technical characteristics

## Loading characteristics

Marking	Description	COMPACT 12 - COMPACT 3347E	COMPACT 14 - COMPACT 3947E
B	Lateral distance between the wheels <sup>1.</sup>	1,86 m(6 ft1 in)	1,86 m(6 ft1 in)
C	Front wheel ground pressure <sup>(1.)</sup>	21,8 kg/cm <sup>2</sup> (44660 lb/ft <sup>2</sup> )	22,6 kg/cm <sup>2</sup> (46330 lb/ft <sup>2</sup> )
D	Rear wheel ground pressure <sup>(1.)</sup>	21,8 kg/cm <sup>2</sup> (44660 lb/ft <sup>2</sup> )	22,6 kg/cm <sup>2</sup> (46330 lb/ft <sup>2</sup> )
	Anchorage point		

1. Check the technical data in the technical characteristics

### 5.3 - UNLOADING

Before unloading, check that the machine is in good condition.

- Remove the tie downs.
- At ground control box turn control box activation switch ( 92 ) to the left to energize platform box.
- On the platform control box, press and hold the activation switch ( 123 ) while gently and progressively moving the drive joystick ( 108 ).



**Warning :** Upon starting a machine that has been secured and transported, the safety system may detect a false overload preventing all movement from the platform control box.

To reinstate the system, lift the platform a few centimetres (inches) from the ground control box.

# D - Operation instructions

## 5.4 - TOWING



In the event of a machine breakdown, the machine can be towed a short distance to load it onto a transport vehicle :

- Ensure that no one is in the platform during towing.
- Before towing, ensure that the platform is fully lowered.
- The platform must be empty.
- **ALWAYS** keep personnel and obstructions clear of the aerial work platform when brakes are released.

To tow a broken-down machine, release brake (Refer to  Section D 5.4.1 - Free wheel mode).

Perform this operation on flat ground with wheels chocked.

In the towing configuration, the machine braking system is inactive. Use of a drawbar is recommended :

- Do not exceed the maximum freewheel speed (Refer to  Section B 4.1 - Technical specifications).
- Do not exceed a grade of 25%.

### 5.4.1 - Free wheel mode

To tow a broken-down machine, perform manual brake release.



Perform these operations on flat, horizontal ground. Failing that, block the wheels to immobilize the machine. When drive hubs are disengaged, the machine is in free wheel mode and the brake system no longer functions.

COMPACT 8 - COMPACT 2032E - COMPACT 8W - COMPACT 2047E - COMPACT 10N -  
 COMPACT 2632E - COMPACT 10 - COMPACT 2747E - COMPACT 12 - COMPACT 3347E  
 - COMPACT 14 - COMPACT 3947E

1. Close the tap ( NV1 ).
2. Open the tap ( NV2 ).
3. Push the pump by hand ( HP1 ) until the brake is fully released.
4. Slow towing.

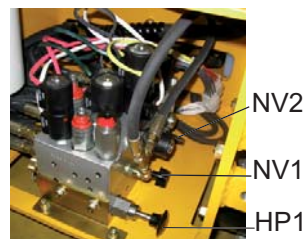

After towing the machine :

5. Close the tap ( NV2 )
6. Open the tap ( NV1 ).



In the towing configuration, the machine is no longer slowed down. Use a drawbar to avoid any risk of accident.



Do not exceed 5 km/h (3,10 mph) .



# D - Operation instructions

## 5.4.2 - Automatic brake release (Option)

To tow a broken-down machine, the brakes on the drive wheels can be released using a remote control allowing brake release to be activated remotely.



**Perform these operations on flat, horizontal ground. Failing that, block the wheels to immobilize the machine. When drive hubs are disengaged, the machine is in free wheel mode and the brake system no longer functions.**

1. Activate brake release using the push button control (ground control box). The motor pump unit is powered for a brief moment. Brake release is effective after approximately 1 s.
2. As long as the button is activated, the brakes on the machine are released (solenoid valves YV10 and YV11 are powered).
3. Tow the machine in low speed.
4. The brakes are reactivated 0,5 s after the push button is released.



**In the towing configuration, the machine is no longer slowed down. Use a drawbar to avoid any risk of accident.**



**Do not exceed 5 km/h (3,10 mph) .**

# D - Operation instructions

## 5.5 - STORAGE



The machine can be stored in a designated area when not in use. If it has been stored for longer than 3 months without use then a periodic inspection must be conducted.



For engine storage condition follow engine supplier operator and maintenance manuals.

It is recommended that the machine is not stored or immobilized unfolded.

Ensure all access panels, doors and side compartment covers are shut and secured.

Turn the energizing key selector switch ( 92 ) at the ground control box to the "center" position to shut OFF the power.

Remove the energizing key to prevent unauthorized operation of the machine.



When machine is stored and not used for more than 1 week, check the battery's state of charge, recharge if necessary.



To avoid any risk of corrosion on rods of cylinders during a storage period of more than 1 month :

- In a normal atmospheric environment : perform a complete cycle for the cylinders every 2 months while they are in storage.
- In harsh environments (high levels of salinity in the atmosphere: close to the sea, industrial environment with chloride emissions and/or humidity >70%), we recommend applying the following protection process :
  - Wash and rinse the entire machine with plenty of clean water.
  - Dry all the cylinder rods using an air gun.
  - Apply a solvent-based oil leaving an oily film after evaporation of the solvent directly to all rods left exposed when the machine is in storage position.
  - Re-apply the product every month.



After washing the machine, make sure it is fully air-dry and does not contain moisture on corrosive parts (cylinders rods for example).

Do not wash any electrical components, particularly with high pressure washer. Wipe away dirt from around electrical components with a dry cloth.

# D - Operation instructions

## 5.6 - LOADING BY RAMP



Ensure that :

- The loading ramp can support the machine weight.
- The loading ramp is correctly attached to transport vehicle.
- The loading ramp has sufficient grip surface.
- The transport vehicle must be parked on a level surface and must be secured to prevent rolling away while machine is being loaded or unloaded.



To climb the slope, move progressively the drive joystick  (or ).

If the slope is too steep, use a winch in addition to traction.



Do not place yourself below or too close to the machine during loading.

- Check the platform is completely empty. Do not use excessive downward force when securing platform/ basket.
- Drive the machine onto the truck bed.
- Secure the machine to the tie down points provided (Refer to  Section D 5.2 - Machine layout).
- The covers /swing out trays must be closed and locked in position. A wrong move can lead to machine tipping over and may cause serious injuries and material damage.

The machine must be completely in the stowed configuration.

The extension deck must be retracted and locked during transport or towing.

## 5.7 - UNLOADING BY RAMP



Before operating, check that the machine is in good condition.

If the machine has been damaged during transportation, contact the transporter in writing

1. Remove the tie downs.
2. Switch the machine on.
3. The ramp is in good condition and of sufficient capacity. The lifting equipment ie. slings, shackles, hooks, lifting beam etc. are in good condition and of sufficient capacity.
4. Move progressively the drive joystick .



Upon starting a machine that has been secured and transported, the safety system may detect a false overload preventing all movement from the platform control box.

To reinstate the system, lift the platform a few centimetres (inches) from the ground control box.

A

B

C

D

E

F

G

H

I

# D - Operation instructions

## 5.8 - LIFTING OPERATION

Before any lifting operation, it is necessary to take into account the following points :



**ONLY trained and authorized personnel should attempt to lift the machine.**

Do not operate machine unless you have :

- been fully trained and are qualified in proper operation.
- read and understood the information in the Operator's manual of the machine.

### 5.8.1 - Safety precautions

It is the responsibility of the Operator to ensure there are no personnel or obstructions to safely perform the operation.

### 5.8.2 - Preliminary procedures

- Inspect the surrounding area and position the machine at a safe distance from electrically charged conductors to ensure that no part of the machine is within an unsafe area. Always stay clear of overhead obstructions.
- Respect the local rules and the minimum safe distance from power lines.
- Stop the machine.
- Remove the ignition key.
- Ensure that the main power is disconnected.
- Place a "DO NOT USE" decal near the start/stop switches to inform personnel that machine is not operational during the lifting process.
- Cordon off the area surrounding the machine to keep personnel, vehicles and moving equipment away from the machine.
- Remove all loose items from the machine.
- Ensure that vehicle capacity of the forklift and lifting equipment - hoists, slings, straps, etc. are of sufficient strength to withstand maximum machine weight.
- Attach the rigging **ONLY** to the designated lifting points on the machine.

# D - Operation instructions

## 5.8.3 - Loading and unloading with forklift

### Unloading

- While lifting, make sure that the load is evenly spread.
- Put down the machine.
- Platform must be fully lowered.
- Manual extension deck(s) must be fully retracted and locked in position. The machine must be in the fully stowed transport position.
- Ensure that the machine controls are in the OFF position.
- Use a forklift with sufficient strength to lift the machine.
- Move the forks apart.
- Place the forks in the positions indicated on the chassis.
- Slowly place the forks in position with forklift pockets to ensure optimum stability.

A

B

C

> D

E

F

G

H

I

# D - Operation instructions

## 5.8.4 - For: COMPACT 8 - COMPACT 2032E - COMPACT 10N - COMPACT 2632E

### Necessary equipment



- PPE (Personal Protective Equipment: glove, safety shoes, glasses, etc ...)
- Standard tool kit
- 4 shackles 2 T
- 4 slings 3 m (9 ft 10 in) 3 T

### Procedure for the use of slings

The machine must be fully folded, with platform extension(s) retracted and locked in position.

Attach 4 shackles 2 T with the straps 3 m (9 ft 10 in) 3 T to the four lifting points on the chassis.

#### Front view of the machine



#### Rear view of the machine



# D - Operation instructions

The slings must be positioned from inside of the railings as shown below.

## Slings and shackles installation

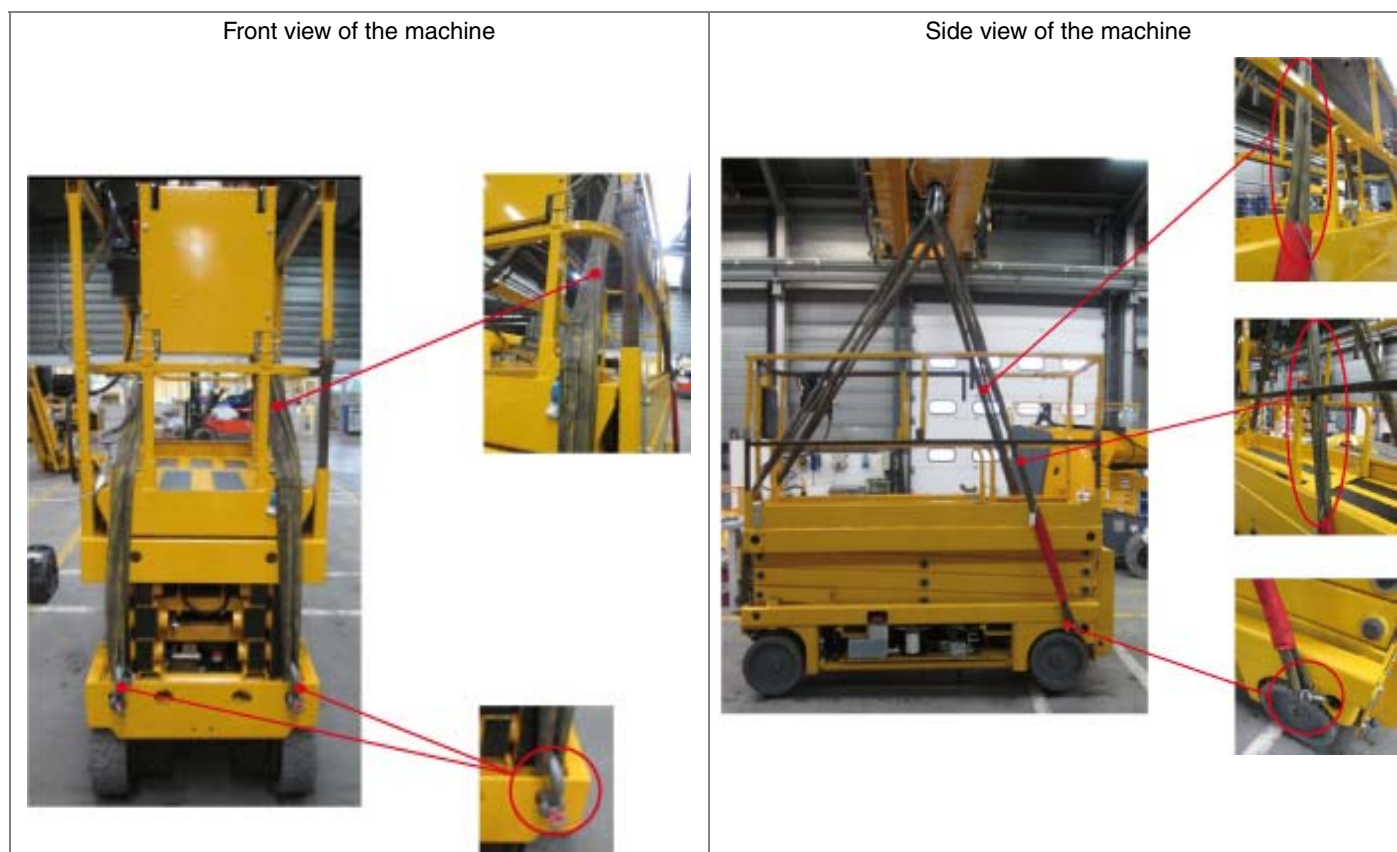

Remove and place the platform control box on the platform floor.

Make sure the slings do not contact critical components as shown below.





# D - Operation instructions

## 5.8.5 - For COMPACT 8W - COMPACT 2047E - COMPACT 10 - COMPACT 2747E - COMPACT 12 - COMPACT 3347E - COMPACT 14 - COMPACT 3947E

### Necessary equipment



- PPE (Personal Protective Equipment: glove, safety shoes, glasses, etc ...)
- Standard tool kit
- 6 shackles 2 T
- 4 slings 3 m (9 ft 10 in) 3 T

### Procedure for the use of slings

The machine must be fully folded, with platform extension(s) retracted and locked in position.  
Hook together 2 - 2 T shackles with a sling 3 m (9 ft 10 in) 3 T to each hole in front of the machine.

#### Front view of the machine



Hook 1 - 2 T shackle with a sling 3 m (9 ft 10 in) 3 T to each hole at the rear of the machine.

#### Rear view of the machine





# D - Operation instructions

## Slings and shackles installation



The deformation that might appear is not permanent, the guardrail will return to its initial shape once the lifting operation is over and the slings are removed.

# D - Operation instructions

## 6 - Cold Weather Recommendations

In extreme cold conditions, machines should be equipped with optional cold start kits.

### 6.1 - ENVIRONMENTAL CONDITIONS

#### 6.1.1 - Hydraulic oil

External environmental conditions can reduce performance of the machine if the hydraulic oil temperature does not reach its optimum range.

It is recommended to use the hydraulic oil according to weather condition. Refer to the table below.

Environmental conditions	SAE Viscosity grade
Ambient temperature between - 15°C (5°F) and + 40°C (+ 104°F)	HV 46
Ambient temperature between - 35°C (- 31°F) and + 35°C (+ 95°F)	HV 32
Ambient temperature between 0°C (+ 32°F) and + 45°C (+ 113°F)	HV 68

***N.B.:-IT IS RECOMMENDED TO REPLACE LOW TEMPERATURE OIL AS THE AMBIENT TEMPERATURE REACHES + 15°C (59°F). IT IS NOT ADVISABLE TO MIX OILS OF DIFFERENT BRANDS OR TYPES.***

# D - Operation instructions

## 7 - Battery care and maintenance

### 7.1 - BATTERY CHARGING

Recharge aerial work platform batteries after each 8 hour work shift or as needed. When the aerial work platform is not in use, batteries should be recharged at least once per week. Under normal circumstances, battery recharge should take approximately 8-10 hours. However, a full recharge may take up to 24 hours, if the battery charge is extremely low.

#### *Battery charger status*

Ground control box :

The indicator (93) indicates charge status.

- Batteries are charging : The green diodes are on( 1 ).
- Batteries being discharged : The diodes go out one after the other( 1 ).
- Batteries discharged : The red diode lights up, this cuts off ascent but driving laterally remains possible( 2 ).

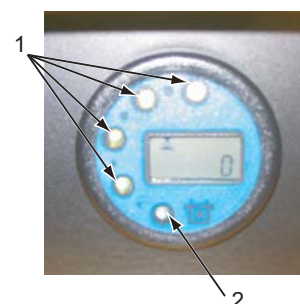

#### *When should the batteries be charged ? :*

- Do not let the battery discharge to below 20 %.
- When the batteries are discharged to between 35 % and 80 % of their nominal capacity.
- If installing new batteries, recharge them after 3 or 4 hours of use 3 to 5 times.
- After a long period of non-use.
- Never leave the batteries discharged.
- Do not put off recharging the batteries in cold weather as the electrolyte may freeze.



- Do not recharge the batteries if the temperature of the electrolyte exceeds 40 °C(104 °F) . Allow to cool down.
- Keep the top of the batteries clean and dry. Incorrect connection or corrosion may cause a high loss of power.
- The charger settings are adjusted in the factory using its own cable. If the cable needs changing, the HAULOTTE® factory must be contacted to obtain authorisation.

# D- Operation instructions

*How to charge the batteries ? :*



**Before charging the batteries, switch the machine off.**

- Use the machine's on-board charger. The charger has a charge rate compatible to the battery capacity.
- Ensure that the mains supply is compatible to the charger's consumption.
- Top up the batteries with distilled water to the minimum electrolyte level if any of the elements are below this minimum level.
- Work in a clean and well-ventilated area away from naked flames.
- Move the aerial work platform to a well-ventilated area with direct access to a AC electrical outlet.

Charger type	24 V -
Electric power supply	220 V single phase 50 Hz
Delivered voltage	24 V
Charging time	Approx. 11 h (hours) for batteries discharged by 70 % to 80 %
Mains connection	Standard plug

*How to maintain battery autonomy ? :*

- Do not charge the batteries in cold temperatures.
- The battery life is reduced when the machine is used in cold temperatures (< 0 °C (32 °F) ).
- If the machine is not going to be used for a length of time, shut-off the power with battery isolation switch(E-stop button ( 15 )).
- Do not let the battery discharge to below 20 %.
- If batteries are deeply discharged (<10%); standard battery charger may not be enough to recharge battery.

*To recharge the aerial work platform batteries :*

Attach a 12 AWG multi-strand, grounded extension cord with a maximum length of 15 m (50 ft) to the receptacle located on the charger.

Plug the extension cord into outlet.

Start-up is automatic as soon as the mains connection is established. The charger is fitted with a LED indicator placed near the special holding frame :

- Green indicator : Battery charged 100 %
- Yellow LED : Battery charged 80 %
- Red LED : Charger in the initial charge phase

The CHARGING indicator LED remains lit continuously during the first stage of the charge cycle. The charge current will be displayed on the BATTERY CHARGER FACEPLATE.

To display the Battery Voltage, press (push) in and hold the BATTERY VOLTAGE button.

# D - Operation instructions



Do not disconnect any output leads or connectors between the batteries and the charger when the charger is on. To stop a charge in progress, always unplug the extension cord from the AC power source.



Recharge batteries in a well-ventilated area only. Do not charge batteries near fire, spark or other potential ignition sources. Batteries may emit highly explosive hydrogen gas while charging. Failure to properly ventilate the charge gasses could result in death or serious injury. Always charge aerial work platform batteries away from flammable materials.



**ALWAYS** avoid contact with battery acid. Battery acid causes serious burns and should be kept away from skin or eyes. If contact occurs, flush with water and consult a physician immediately.

When there is a fault, the LED indicator flashes in various colours depending on the type of alarm :

State of flashing indicator	Type of alarm	Description (Action)
Red	Battery presence	Battery not connected or not compliant : Check connection or rated voltage.
Yellow	Temperature probe	Temperature probe disconnected while charging or outside the functional range : Check connection and measure battery temperature.
Green	Specified time	Phase 1 or 2 is longer than the maximum allowed time : Check battery capacity.
Red-Yellow	Battery current	Loss of output current control : Faulty control logic.
Red-Green	Battery voltage	Loss of output voltage control : Battery disconnected or faulty control logic.
Red-Yellow-Green	Temperature	Overheating of semiconductors : Check fan operation.

In case of an alarm, the charger stops supplying power.

When the battery charge reaches 80% of capacity, the yellow 80% CHARGED indicator LED will become lit and the green CHARGING indicator LED will begin to flash.

Unplug the extension cord from the outlet and the charger receptacle on the aerial work platform. Store the extension cord for next use.

***N.B.:-ALWAYS UNPLUG THE BATTERY CHARGER POWER CORD BEFORE MOVING THE AERIAL WORK PLATFORM. FAILURE TO DISCONNECT POWER CORD COULD CAUSE DAMAGE TO THE EQUIPMENT.***

*Maintenance load :*

When the charger is connected to the mains for more than 48 h (hours), a new charging cycle starts up at the end of the previous charging cycle in order to offset self-discharge.

*Charge interruption :*

To turn off the charger, disconnect it from the mains supply.

Should the machine need to be operated during a charging cycle, first disconnect the charger. This may reduce the life span of the batteries. Re-connect the charger once the operation is over.





# E - General Specifications

## 1 - Machine dimensions

**Stowed / Transport position : Configuration that takes the minimum floor space necessary for storage and / or delivery of the machine - Access position - COMPACT 8 - COMPACT 2032E - COMPACT 8W - COMPACT 2047E - COMPACT 10N - COMPACT 2632E - COMPACT 10 - COMPACT 2747E - COMPACT 12 - COMPACT 3347E - COMPACT 14 - COMPACT 3947E**

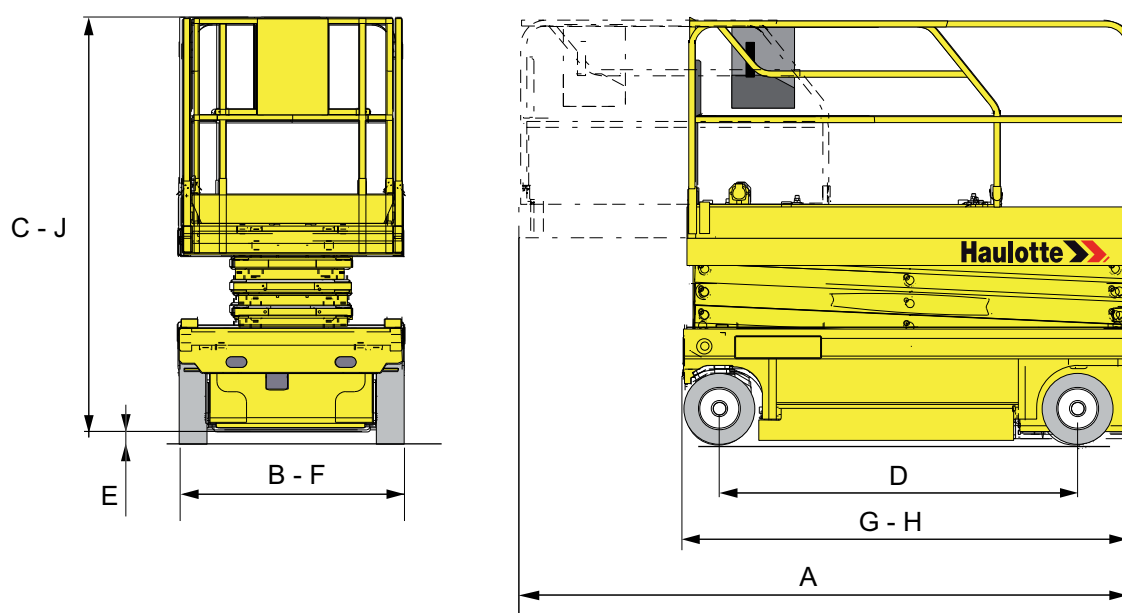



# E - General Specifications

## Overall dimension specifications

Marking	COMPACT 8 - COMPACT 2032E		COMPACT 8W - COMPACT 2047E	
	Mètre	Feet inch	Mètre	Feet inch
A	3,40	11 ft 1 in	3,40	11 ft 1 in
B	0,80	2 ft 7 in	1,20	3 ft 11 in
C	1,99	6 ft 6 in	2,14	7 ft
D	1,86	6 ft 1 in	1,86	6 ft 1 in
E	0,13	0 ft 5 in	0,13	0 ft 5 in
F x G	2,30 x 0,80	7 ft 6 in x 2 ft 7 in	2,30 x 1,20	7 ft 6 in x 3 ft 11 in
H	2,30	7 ft 6 in	2,30	7 ft 6 in
J	1,99	6 ft 6 in	2,14	7 ft

Marking	COMPACT 10N - COMPACT 2632E		COMPACT 10 - COMPACT 2747E	
	Mètre	Feet inch	Mètre	Feet inch
A	3,40	11 ft 1 in	3,40	11 ft 1 in
B	0,80	2 ft 7 in	1,20	3-11
C	2,18	7 ft 1 in	2,26	7 ft 5 in
D	1,86	6 ft 1 in	1,86	6 ft 1 in
E	0,13	0 ft 5 in	0,13	0 ft 5 in
F x G	2,30 x 0,80	7 ft 6 in x 2 ft 7 in	2,30 x 1,20	7 ft 6 in x 3 ft 11 in
H	2,30	7 ft 6 in	2,30	7 ft 6 in
J	2,18	7 ft 1 in	2,26	7 ft 5 in

Marking	COMPACT 12 - COMPACT 3347E		COMPACT 14 - COMPACT 3947E	
	Mètre	Feet inch	Mètre	Feet inch
A	3,40	11 ft 1 in	3,40	11 ft 1 in
B	1,20	3 ft 11 in	1,20	3 ft 11 in
C	2,38	7 ft 9 in	2,50	7 ft 9 in
D	1,86	6 ft 1 in	1,86	6 ft 1 in
E	0,13	0 ft 5 in	0,13	0 ft 5 in
F x G	2,30 x 1,20	7 ft 1 in x 3 ft 11 in	2,30 x 1,20	7 ft 1 in x 3 ft 11 in
H	2,30	7 ft 6 in	2,30	7 ft 6 in
J	2,38	7 ft 9 in	2,50	7 ft 9 in

A

B

C

D

E

F

G

H

I

# E - General Specifications

## 2 - Major component masses

Specifications	COMPACT 8	COMPACT 2032E
	SI	Imp.
Frame assembly mass	933 kg	2057 lbs
Scissors assembly mass	522 kg	950 lbs
Platform assembly mass	200 kg	275 lbs
Drive wheel mass	22,5 kg	50 lbs
Steer wheel mass	22,5 kg	50 lbs
Battery mass	112 kg	247 lbs

Specifications	COMPACT 8W	COMPACT 2047E
	SI	Imp.
Frame assembly mass	1173 kg	2586 lbs
Scissors assembly mass	607 kg	1338 lbs
Platform assembly mass	250 kg	551 lbs
Drive wheel mass	22,5 kg	50 lbs
Steer wheel mass	22,5 kg	50 lbs
Battery mass	160 kg	353 lbs

Specifications	COMPACT 10	COMPACT 2747E
	SI	Imp.
Frame assembly mass	1173 kg	2586 lbs
Scissors assembly mass	812 kg	1790 lbs
Platform assembly mass	250 kg	551 lbs
Drive wheel mass	22,5 kg	50 lbs
Steer wheel mass	22,5 kg	50 lbs
Battery mass	160 kg	353 lbs

Specifications	COMPACT 10N	COMPACT 2632E
	SI	Imp.
Frame assembly mass	1193 kg	2631 lbs
Scissors assembly mass	797 kg	1757 lbs
Platform assembly mass	200 kg	441 lbs
Drive wheel mass	22,5 kg	50 lbs
Steer wheel mass	22,5 kg	50 lbs
Battery mass	112 kg	247 lbs

# E - General Specifications

Specifications	COMPACT 12	COMPACT 3347E
	SI	Imp.
Frame assembly mass	1173 kg	2586 lbs
Scissors assembly mass	1047 kg	2309 lbs
Platform assembly mass	250 kg	551 lbs
Drive wheel mass	22,5 kg	50 lbs
Steer wheel mass	22,5 kg	50 lbs
Battery mass	160 kg	353 lbs

Specifications	COMPACT 14	COMPACT 3947E
	SI	Imp.
Frame assembly mass	1405 kg	3335 lbs
Scissors assembly mass	1519 kg	950 lbs
Platform assembly mass	250 kg	551 lbs
Drive wheel mass	22,5 kg	50 lbs
Steer wheel mass	22,5 kg	50 lbs
Battery mass	172 kg	379 lbs
Counterweight assembly mass	234 kg	754 lbs

## 3 - Acoustics and vibrations

The acoustics and vibrations specifications are based upon the following conditions :

- The airborne noise emissions at workstation are determined per European Directive 2006/42/CE.
- The guaranteed sound power level LWA (displayed on the product) is determined per European Directive 2000/14/CE.
- The vibrations transmitted by the machinery to the hand/arm system and to the whole body are determined per European Directive 2006/42/CE.

Specifications	
Sound pressure level at workstation	< 70 dBA
Vibrations hand/arm	Vibration transmitted by this MEWP to the hand-arm does not exceed 2,5 m/s <sup>2</sup> (98,4 in/s <sup>2</sup> )
Vibrations whole body	Vibration transmitted by this MEWP to the whole body does not exceed 0,5 m/s <sup>2</sup> (19,6 in/s <sup>2</sup> )

# E- General Specifications

## 4 - Wheel/Tire assembly

### 4.1 - TECHNICAL SPECIFICATIONS

**COMPACT 8 - COMPACT 2032E - COMPACT 8W - COMPACT 2047E -  
 COMPACT 10N - COMPACT 2632E - COMPACT 10 - COMPACT 2747E -  
 COMPACT 12 - COMPACT 3347E - COMPACT 14 - COMPACT 3947E**

Component	Standard wheel
Reference number	Solideal
Type	Solid tires/tyres
Size	378 mm / 125 mm (14,8 in/ 4,9 in)
Torque	250 daN

### 4.2 - INSPECTION AND MAINTENANCE

Replace the wheels and the tires if any of the following conditions exist :

- Presence of cracks, damage, deformation or other faults on the hub
- Damage to the tire :
  - Cut or hole > 3 cm (2 in) in the rubber side wall.
  - Blister or pronounced lump on the external and lateral wall.
  - Damaged wheel stud.
  - Damage or wear on the side wall to the extent that the reinforcing wire is visible.
  - Consistent wear of the ground contact surface greater than 25%

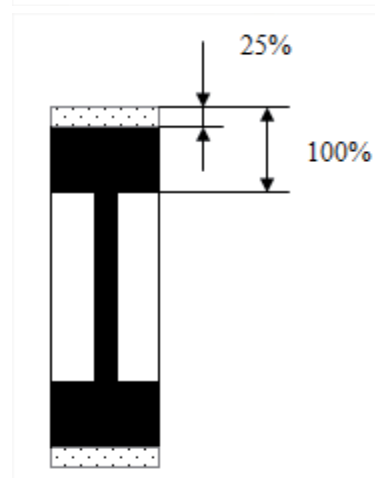
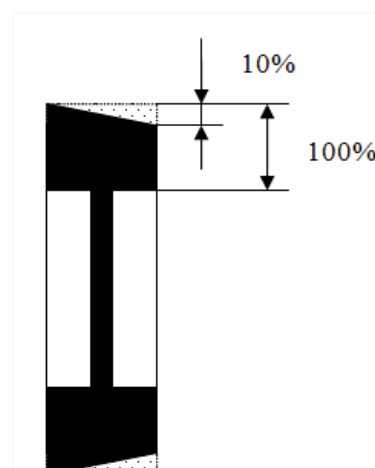

Tires and rims are critical components for the stability of the machine. For safety reasons :

- Use only HAULOTTE® spare parts according to the technical characteristics of the machine. Refer to the spare parts catalog.
- Do not replace factory-installed tires with tires of different specifications or ply rating.

# E- General Specifications

## 4.2.1 - Procedure of replacement

1. Loosen the wheel nuts on the wheel to be removed.
2. Raise the machine using a jack or a hoist.
3. Remove the wheel nuts.
4. Remove the wheel.
5. Install the new wheel.
6. Lower the machine to the ground.
7. Tighten the wheel nuts to the recommended torque



# E - General Specifications

## 5 - Options

### 5.1 - PIPE HOLDER OPTION

#### 5.1.1 - Description

This attachment is an assembly designed to transport pipes and tubes. The assembly comprises of 2 cradles securely attached to the platform. The tube should be placed in the cradles and securely fixed to them with a strap.

#### 5.1.2 - Characteristics

Specifications	COMPACT 8 / 10 N		COMPACT 2032E / 2632E	
	SI	Imp.	SI	Imp.
Weight of the carrier	9 kg	20 lbs		
Weight of the equipment on the carrier	50 kg	110 lbs		
Maximum load surface	0,6 m <sup>2</sup> (Ø 0,2 m x 3 m)	6.46 sq.ft (Ø 8 in x 9 ft 10 in)		
Maximum wind speed allowed	0 m/s - 0 km/h	0 mph		

Specifications	COMPACT 8W / 10 / 12 / 14		COMPACT 2247E / 2747E / 3347E / 3947E	
	SI	Imp.	SI	Imp.
Weight of the carrier	9 kg	20 lbs		
Weight of the equipment on the carrier	70 kg	154 lbs		
Maximum load surface	0,6 m <sup>2</sup> (Ø 0,2 m x 3 m)	6.46 sq.ft (Ø 8 in x 9 ft 10 in)		
Maximum wind speed allowed	0 m/s - 0 km/h	0 mph		

#### 5.1.3 - Safety precautions



- Please read and assimilate the instructions before using the attachment.
- This attachment is designed for transporting pipes and tubes. Do not use this attachment for transporting other types of load.
- Do not suspend loads.
- Do not overload the attachment and ensure that the material is correctly attached by straps.
- Do not exceed the maximum allowable platform capacity. The combined weight of the attachment, load, the occupants, the tools and any other equipment must not exceed the maximum allowable platform capacity.
- Do not load tubes whose surface area exceeds the maximum authorized surface area. Exposing an additional surface area to the wind reduces machine stability. Do not install any other attachments that increase the surface area exposed to the wind.
- Do not use the machine if the wind speed exceeds the authorized limit of the attachment.
- The cradles should always be positioned such that they are within the platform. Position the bottom end of the cradles such that they are resting on the platform floor.
- When maneuvering, ensure you maintain a safe distance between the load and the obstacles in the work environment.

# E- General Specifications

## 5.1.4 - Pre-operation inspection



- Check that the cradle has no cracks or other damage.
- Check that the cradle is correctly installed and secured to the platform(Ensure fastening screws are tightened and pins correctly positioned).
- Check that the information decal is present on the cradle and is legible.
- Check that the strap(s) is(are)not twisted or torn.
- Check that the position of the load and attachment is not obstructing access to the platform or the controls.
- Check that the position of the attachment and the load is not reducing visibility during maneuvers in the work environment.

## 5.1.5 - Operation

- Position and centre the load to rest on the 2 cradles.
- Securely attach the load to each cradle with supplied straps.

### Strapping example(s)

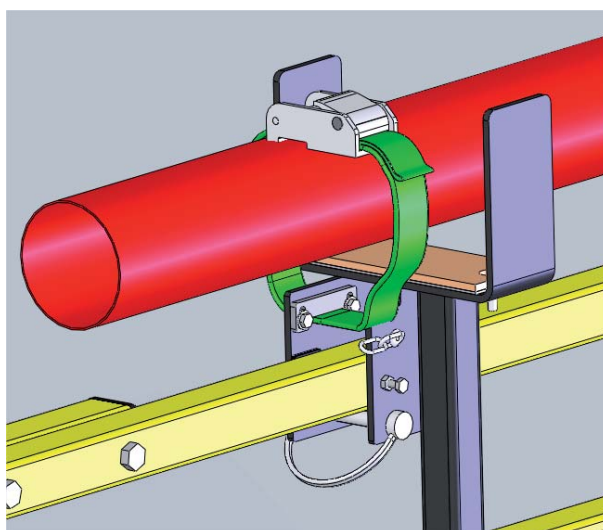



# E- General Specifications

## 5.1.6 - Disassembly - Assembly

### 5.1.6.1 - Without option

COMPACT 8 / 8W / 10 / 10N / 12 / 14 - COMPACT 2032E / 2247E / 2632E / 2747E / 3347E / 3947E

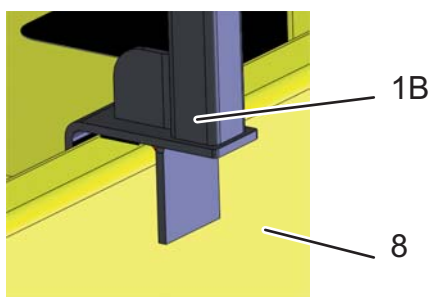
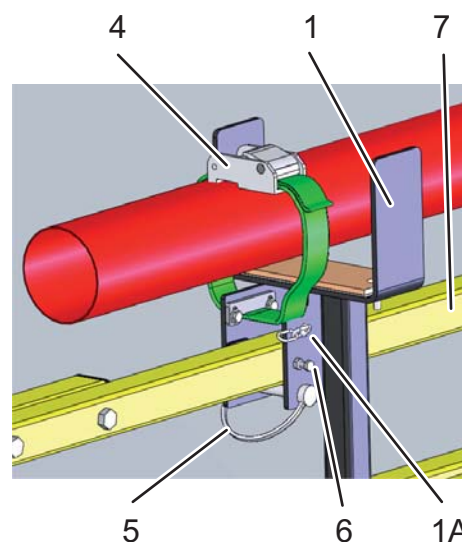
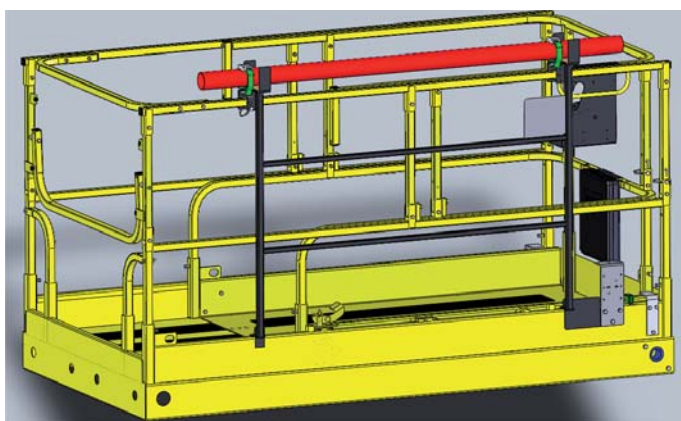

Marking	Description
1 - 1A - 1B - 1C	Carrier
2	Spring washer
3	Fastening screw
4	Strap
5	Dowel pin
6	Adjustment screw
7	Guardrail
8	Platform

- Straddle the support pipes (1, 1A, 1B) and (1C) on the structure of the fixed or folding guard rails (7).
- Lock in place with the pin (5).
- Tighten the 3 screws (3) and 3 washers (2) to the recommended torque

**N.B.-:TORQUE REQUIREMENTS : 22 NM (16 FT LBS)**



# E- General Specifications

- Pre-operation test : Place and secure the load of : Compact 8, 10N : 50 kg (110 lbs) - Compact 8W, 10, 12, 14 : 70 kg (154 lbs) max. on the cradle. Ensure that the cradle can support the load and that there is no visual structural damage.

## 5.1.6.2 - Work light or platform supply option

COMPACT 8 / 8W / 10 / 10N / 12 / 14 - COMPACT 2032E / 2247E / 2632E / 2747E / 3347E / 3947E

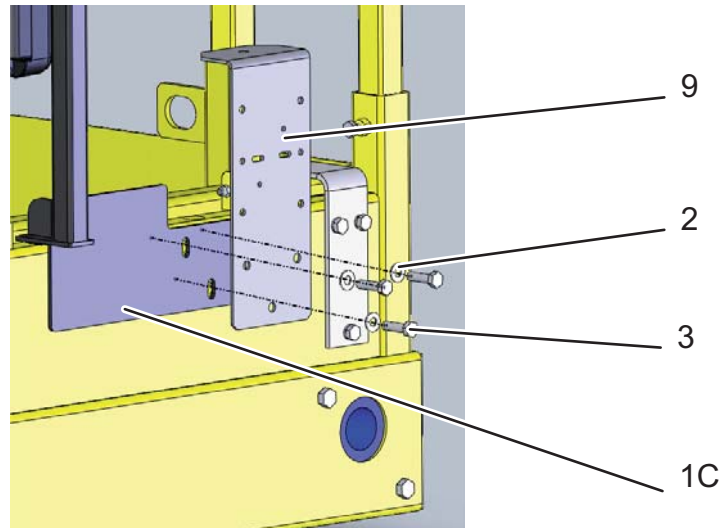
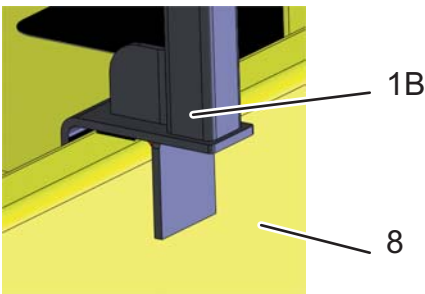
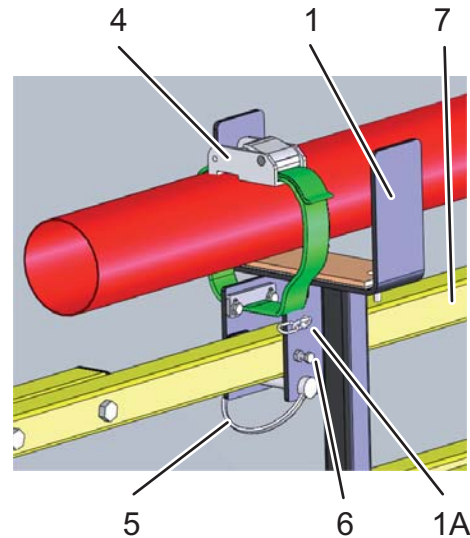
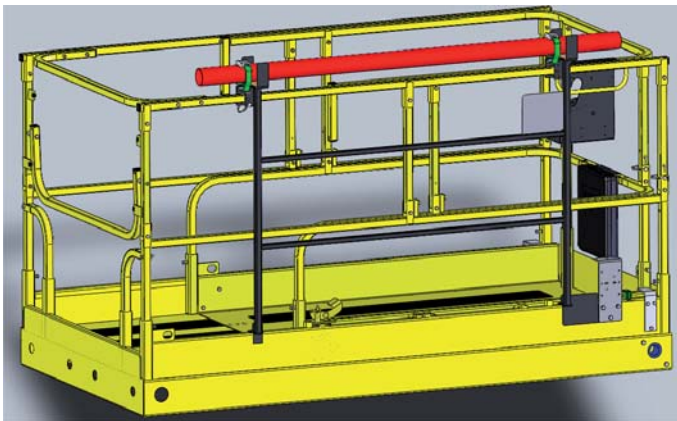

Marking	Description
1 - 1A - 1B - 1C	Carrier
2	Spring washer
3	Fastening screw
4	Strap
5	Dowel pin
6	Adjustment screw
7	Guardrail
8	Platform
9	Mounting plate option

# E- General Specifications

- Unscrew the 3 screws of the mounting plate option ( 9 ) and position the assembly in the extension.
- Straddle the support pipes ( 1, 1A, 1B ) and ( 1C ) on the structure of the fixed or folding guard rails ( 7 ).
- Lock in place with the pin ( 5 ).
- Position above the mounting plate option ( 9 )
- Tighten the 3 screws ( 3 ) and 3 washers ( 2 ) to the recommended torque.

**N.B.-:TORQUE REQUIREMENTS : 22 NM (16 FT LBS)**

- Pre-operation test : Place and secure the load of : Compact 8, 10N : 50 kg (110 lbs) - Compact 8W, 10, 12, 14 : 70 kg (154 lbs) max. on the cradle. Ensure that the cradle can support the load and that there is no visual structural damage.

### 5.1.7 - Specific decals

Location of the decals

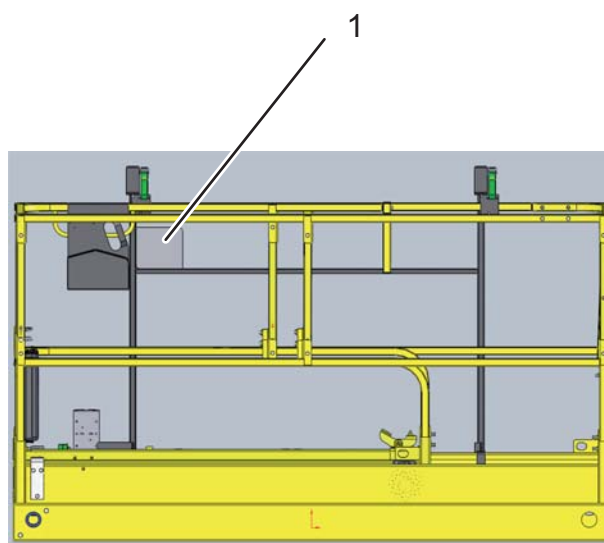

**COMPACT 8 / 8W / 10 / 10N / 12 / 14 - COMPACT 2032E / 2247E / 2632E / 2747E / 3347E / 3947E**

Marking	Description	Quantity	Part number
1	Risk of overturning	1	In english CE - ANSI : 4000676460 In french CE - ANSI : 4000676450 In spanish CE - ANSI: 4000676470 In german CE - ANSI: 4000673350

# E - General Specifications

## 5.2 - SWING GATE

### 5.2.1 - Description

"SWING GATE" consists of a laterally mounted pivoting  $\frac{1}{2}$  gate with closing latch, which enables a better access to platform. Spring loaded hinges and a latching mechanism allows the gate to swing inwards only.

### 5.2.2 - Characteristics

### 5.2.3 - Safety precautions



- The gate is part of the guardrail system and must be securely fastened after entering the platform.
- Pay attention to the toe board when entering or exiting the platform.

### 5.2.4 - Pre-operation instructions

- Inspect that the latching mechanism is securely fastened.
- Check the hinges and latch operate correctly and are not deformed.
- Ensure that the gate returns automatically to the closed and fastened position after entering or exiting the platform.

A

B

C

D

E

F

G

H

I



# F - Maintenance

## 1 - General

As an owner and/or operator of Haulotte equipment, your Safety is of utmost importance to HAULOTTE®, which is why HAULOTTE® places such a high priority on product safety.

INSPECTIONS are not only required by HAULOTTE®, but may also be required by industry standards and/or local regulations.

To ensure your equipment continues to achieve the level of performance set in the factory, it is important to maintain it regularly. We remind you that it is strictly forbidden to make any modifications. Regular and timely inspections will reduce equipment down time as well as prevent possible injury.

***N.B.-:DO NOT OPERATE UNLESS YOU ARE FAMILIAR AND TRAINED IN THE PRINCIPLES OF SAFE MACHINE OPERATION.***

*Overview :*

- Walk-around inspections take only a few minutes at the beginning and end of each shift – one of the best ways to prevent mechanical problems and safety hazards.

*What to Do :*

- Use your senses: sight, smell, hearing and touch.

*Frequency :*

- Check your machine periodically during your entire workday.
- Make sure to do your inspection the same way every time.
- Complete one of these inspections at the start and end of each shift.

***N.B.-:IF DAMAGE OR UNAUTHORIZED MODIFICATIONS ARE DISCOVERED, THE MACHINE MUST BE REMOVED FROM SERVICE UNTIL REPAIRS ARE MADE BY A QUALIFIED SERVICE TECHNICIAN.***

It is the owner's responsibility to ensure the required maintenance as recommended by Haulotte is completed prior to the operation of the machine.

If regular maintenance is not carried out, this may :

- Void the warranty.
- Cause machine malfunction.
- Reduce machine reliability and shorten its service life.
- Jeopardize operator safety.

HAULOTTE Services® technicians are specially trained to carry out extensive repairs, interventions or adjustments on the safety systems or elements of HAULOTTE® machines. They carry genuine HAULOTTE spare parts and tools as required, and also provide fully documented reports on all work completed.

The inspection and maintenance table, identifies the role and the responsibilities of each party in periodical machine maintenance.  Section C 3 - Inspection and Functional test.

# F - Maintenance

## 2 - Maintenance Schedule

This section provides the necessary information needed to place the machine in safe operation. In accordance with the regulations that are currently applicable, this machine is designed to have a 10 year life span in normal usage conditions. The life may be extended or reduced dependent on the severity of operating conditions, the machine condition itself and by conducting effective inspections and maintenance in addition to other external factors. There are a number of factors which can affect the design life including but not limited to, severity of operating conditions/routine maintenance which should be carried out in accordance with this manual.

Severity of operating conditions may require a reduction in time between maintenance periods. Machines that have been out of service or have not been in use for more than 3 months must undergo a periodic inspection before the machine is put back into service.

Maintenance must be carried out by a competent company or person familiar with mechanical procedures.

Maintenance operations performed must be recorded in a register / log book of the machine.

# F - Maintenance

## 3 - Inspection program

### 3.1 - GENERAL PROGRAM

The machine must be inspected on a regular basis at intervals of no less than once 1 per year. The purpose of the inspection is to detect any defect which could lead to an accident during routine use of the machine. Local standards and regulations may require more frequent inspections.

HAULOTTE® requires Reinforced and Major Inspections to be carried out on the product to extend its service life.

Inspections must be carried out by a competent company or person.

The inspection results must be recorded in the safety register or machine log book controlled and overseen by the company manager. This register or machine log book and the list of competent repair persons must be made available to the government work inspector and HAULOTTE Services®.

When	Responsible	Stakeholder	What
Before sale	Owner (or renter)	Competent technician or qualified technician HAULOTTE Services®	Periodic inspection
Before rent	Owner (or renter)	Competent technician or qualified technician HAULOTTE Services®	Daily inspection
Before use or every change of user	User	User	
Annually ( 1 year)	Owner (or renter)	Competent technician or qualified technician HAULOTTE Services®	Periodic inspection
5 years	Owner (or renter)	Qualified technician HAULOTTE Services®	Reinforced inspection
10 years	Owner (or renter)	Qualified technician HAULOTTE Services®	Major inspection

### 3.2 - DAILY INSPECTION

The Daily inspection includes a visual inspection, operational checks and testing of the safety systems. This must be conducted by the operator before using the machine.

This inspection is the responsibility of the user. Refer to  Section C 3.1 - Daily inspection.

# F - Maintenance

## 3.3 - PERIODIC INSPECTION

The Periodic inspection is a thorough evaluation of the operation and safety features of the machine.

It must be conducted before the sale / resale of the machine and/or at least once every year.

Local regulations may have specific requirements on frequency, and content of inspections.

The severity of operating conditions may require frequent inspections.

This inspection is the responsibility of the owner, and inspections must be carried out by a competent company or person.

This inspection is in addition to the daily inspection.

This inspection should also be conducted after :

- Extensive dismantling and reassembly of major components.
- Repairs involving the machine's essential components.
- Any accident causing stress to the machine.

## 3.4 - REINFORCED INSPECTION

The Reinforced inspection is a thorough evaluation of the machine's structural components, to ensure proper functionality of the machine.

This evaluation must occur at a frequency of 5000 hours or every 5 years.

This inspection is the responsibility of the owner, and it must be conducted by a HAULOTTE Services® technician or by a competent company or person.

This inspection includes :

- Daily inspection
- Periodic inspection

***N.B.-:REFER TO THE MAINTENANCE MANUAL FOR DETAILS.***



# F - Maintenance

## 3.5 - MAJOR INSPECTION

The Major inspection is a thorough evaluation of the machine's integrity and proper functioning; after a normal service life of 10 years.

This evaluation must take place after 10 years of operation and then repeated every 5 years thereafter.

The severity of operating conditions may require frequent inspections.

This inspection is the responsibility of the owner, and it must be conducted by a HAULOTTE Services® technician or by a competent company or person.

This inspection includes :

- Daily inspection
- Periodic inspection
- Reinforced inspection

***N.B.-:-REFER TO THE MAINTENANCE MANUAL FOR DETAILS.***

A

B

C

D

E

➤ F

G

H

I

# F - Maintenance

## 4 - Repairs and adjustments

Extensive repairs, interventions or adjustments on the safety systems or components must be performed by a HAULOTTE Services® technician. Use original spare parts and components only.

***N.B.-:HAULOTTE SERVICES® TECHNICIANS ARE TRAINED PROFESSIONALS TO PERFORM EXTENSIVE REPAIRS, INTERVENTIONS AND ADJUSTMENTS ON THE SAFETY SYSTEMS OR COMPONENTS OF HAULOTTE® MACHINES. THE TECHNICIAN CARRIES GENUINE HAULOTTE® SPARE PARTS AND TOOLS AS REQUIRED, AND ALSO PROVIDES FULLY DOCUMENTED REPORTS ON ALL WORK COMPLETED.***

HAULOTTE Services® will not take responsibility for any outcomes resulting from inferior services or repairs performed by other unauthorised personnel.

HAULOTTE® reminds that NO modifications SHALL be carried out without the written permission of HAULOTTE®.

Any unauthorised repairs/modifications will void HAULOTTE® warranty.

To check for safety campaigns, consult our website : [www.haulotte.com](http://www.haulotte.com)



***N.B.-:WHEN DISPOSING OR SCRAPPING THIS MACHINE, PLEASE CONSIDER APPROPRIATE METHODS OF RECYCLING. ANY ITEMS THAT REQUIRE SPECIFIC DISPOSAL ARE LISTED WITH INSTRUCTIONS IN THE MAINTENANCE MANUAL.***

# G - Other information

## 1 - Conditions of warranty



### + Cher client,

Les conditions de garanties mentionnées dans ce manuel ne sont plus valables.

Nous vous invitons à consulter nos conditions garantie actualisées depuis nos sites internet.

### Dear customer,

The warranty conditions stated in this manual are no longer valid. Please consult our updated warranty conditions on our websites.

4001088220

Our warranty conditions and extension contracts are now available on the websites of our sales network : [www.haulotte.com](http://www.haulotte.com)

A

B

C

D

E

F

➤ G

H

I

# G - Other information

## 2 - Subsidiary contact information

	<p>HAULOTTE FRANCE PARC DES LUMIERES 601 RUE NICEPHORE NIEPCE 69800 SAINT-PIERRE <b>TECHNICAL Department:</b> <b>+33 (0)820 200 089</b> <b>SPARE PARTS : +33 (0)820 205 344</b> FAX : +33 (0)4 72 88 01 43 E-mail : <a href="mailto:haulottefrance@haulotte.com">haulottefrance@haulotte.com</a> <a href="http://www.haulotte.fr">www.haulotte.fr</a></p>		<p>HAULOTTE ITALIA VIA LOMBARDIA 15 20098 SAN GIULIANO MILANESE (MI) <b>TEL: +39 02 98 97 01</b> FAX: +39 02 9897 01 25 E-mail : <a href="mailto:haulotteitalia@haulotte.com">haulotteitalia@haulotte.com</a> <a href="http://www.haulotte.it">www.haulotte.it</a></p>		<p>HAULOTTE INDIA Unit No. 1205, 12th floor, Bhumiraj Costarica, Plot No. 1&amp;2, Sector 18, Palm Beach Road, Sanpada, Navi Mumbai- 400 705 Maharashtra, INDIA <b>Tel. : +91 22 66739531 to 35</b> E-mail : <a href="mailto:hlindia@haulotte.com">hlindia@haulotte.com</a> <a href="http://www.haulotte.in">www.haulotte.in</a></p>
	<p>HAULOTTE HUBARBEITSBÜHNEN GmbH Ehrenkirchener Strasse 2 D-79427 ESCHBACH <b>TEL : +49 (0) 7634 50 67 - 0</b> FAX : +49 (0) 7634 50 67 - 119 E-mail : <a href="mailto:adv-gmbh@haulotte.com">adv-gmbh@haulotte.com</a> <a href="http://www.haulotte.de">www.haulotte.de</a></p>		<p>HAULOTTE VOSTOK 61A, bld.1, RYABINOVAYA STREET 121471 MOSCOW RUSSIA <b>TEL/FAX : +7 495 221 53 02 / 03</b> E-mail : <a href="mailto:salesrus@haulotte.com">salesrus@haulotte.com</a> <a href="http://www.haulottevostok.ru">www.haulottevostok.ru</a></p>		<p>HAULOTTE DO BRASIL Av. Alameda Caiapós, 589 CEP: 06460-110 – TAMBORÉ BARUERI – SÃO PAULO – BRASIL <b>TEL : +55 11 4196 4300</b> FAX : +55 11 4196 4316 E-mail : <a href="mailto:haulottebrasil@haulotte.com">haulottebrasil@haulotte.com</a> <a href="http://www.haulotte.com.br">www.haulotte.com.br</a></p>
	<p>HAULOTTE IBERICA C/ARGENTINA Nº 13 - P.I. LA GARENA 28806 ALCALA DE HENARES MADRID <b>TEL : +34 902 886 455</b> TEL SAT : +34 902 886 444 FAX : +34 911 341 844 E-mail : <a href="mailto:iberica@haulotte.com">iberica@haulotte.com</a> <a href="http://www.haulotte.es">www.haulotte.es</a></p>		<p>HAULOTTE POLSKA Sp. z o.o. UL. GRANICZNA 22 05-090 RASZYN - JANKI <b>TEL : +48 22 720 08 80</b> FAX : +48 22 720 35 06 E-mail : E-mail : <a href="mailto:haulottepolska@haulotte.com">haulottepolska@haulotte.com</a> <a href="http://www.haulotte.pl">www.haulotte.pl</a></p>		<p>HAULOTTE MÉXICO, S.A. de C.V. Calle 40 SUR ESQUINA 13 ESTE No. 5/N Colonia CIVAC, JIUTEPEC, MORELOS CP 62578 México <b>TEL : +52 77 7321 7923</b> FAX : +52 77 7516 8234 E-mail : <a href="mailto:haulotte.mexico@haulotte.com">haulotte.mexico@haulotte.com</a> <a href="http://www.haulotte.com.mx">www.haulotte.com.mx</a></p>
	<p>HAULOTTE in JAPAN SBJ ShinOsaka BLDG 3F 4-6-5 Nishinakajima Yodogawa-ku, Osaka, JAPAN, Post Code: 532-0011 <b>TEL : +81 6 6795 9008</b> FAX : +81 6 6795 9009 <a href="http://www.haulotte.com">www.haulotte.com</a></p>		<p>HAULOTTE SINGAPORE Pte Ltd. No.26 CHANGI NORTH WAY, SINGAPORE 498812 <b>Parts and service Hotline:</b> <b>+65 6546 6150</b> FAX : +65 6536 3969 E-mail : <a href="mailto:haulotteasia@haulotte.com">haulotteasia@haulotte.com</a> <a href="http://www.haulotte.sg">www.haulotte.sg</a></p>		<p>HAULOTTE MIDDLE EAST FZE PO BOX 293881 Dubai Airport Free Zone DUBAI United Arab Emirates <b>TEL : +971 (0)4 299 77 35</b> FAX : +971 (0) 4 299 60 28 E-mail : <a href="mailto:haulottemiddle-east@haulotte.com">haulottemiddle-east@haulotte.com</a> <a href="http://www.haulotte.ae">www.haulotte.ae</a></p>
	<p>HAULOTTE SCANDINAVIA AB Taljegårdsgatan 12 431 53 Mölndal SWEDEN <b>TEL : +46 31 744 32 90</b> <b>FAX : +46 31 744 32 99</b> E-mail : <a href="mailto:info@se.haulotte.com">info@se.haulotte.com</a> <a href="mailto:spares@se.haulotte.com">spares@se.haulotte.com</a> <a href="http://www.haulotte.se">www.haulotte.se</a></p>		<p>HAULOTTE TRADING (SHANGHAI) Co. Ltd. #7 WORKSHOP No 191 HUA JIN ROAD MIN HANG DISTRICT SHANGHAI 201108 CHINA <b>TEL : +86 21 6442 6610</b> FAX : +86 21 6442 6619 E-mail : <a href="mailto:haulotteshanghai@haulotte.com">haulotteshanghai@haulotte.com</a> <a href="http://www.haulotte.cn">www.haulotte.cn</a></p>		<p>HAULOTTE ARGENTINA Ruta Panamericana Km. 34,300 (Ramal A Escobar) 1615 Gran Bourg (Provincia de Buenos Aires) Argentina <b>TEL : +54 33 27 445991</b> FAX : +54 33 27 452191 E-mail : <a href="mailto:haulotteargentina@haulotte.com">haulotteargentina@haulotte.com</a> <a href="http://www.haulotte.com.ar">www.haulotte.com.ar</a></p>
	<p>HAULOTTE UK Ltd 1 Gravely Way Four Ashes Wolverhampton WV10 7GW ENGLAND <b>TEL : +44 (0)1216 199753</b> FAX : +44 (0)1952 292758 E-mail : <a href="mailto:salesuk@haulotte.com">salesuk@haulotte.com</a> <a href="http://www.haulotte.co.uk">www.haulotte.co.uk</a></p>		<p>HAULOTTE GROUP / BILJAX 125 TAYLOR PARKWAY ARCHBOLD, OH 43502 – USA <b>TEL : +1 419 445 8915</b> FAX : +1 419 445 0367 Toll free : +1 800 537 0540 E-mail : <a href="mailto:sales@us.haulotte.com">sales@us.haulotte.com</a> <a href="http://www.haulotte-usa.com">www.haulotte-usa.com</a></p>		<p>HAULOTTE NORTH AMERICA 3409 Chandler Creek Rd. VIRGINIA BEACH, VA 23453 – USA <b>TEL : +1 757 689 2146</b> FAX : +1 757 689 2175 Toll free : +1 800 537 0540 E-mail : <a href="mailto:sales@us.haulotte.com">sales@us.haulotte.com</a> <a href="http://www.haulotte-usa.com">www.haulotte-usa.com</a></p>
	<p>HAULOTTE NETHERLANDS BV Koopvaardijweg 26 4906 CV OOSTERHOUT - Nederland <b>TEL : +31 (0) 162 670 707</b> FAX : +31 (0) 162 670 710 E-mail <a href="mailto:info@haulotte.nl">info@haulotte.nl</a> <a href="http://www.haulotte.nl">www.haulotte.nl</a></p>		<p>HAULOTTE AUSTRALIA PTY Ltd 51 Port Link Drive DANDENONG – VIC – 3175 <b>TEL : 1 300 207 683</b> FAX : +61 (0)3 9792 1011 E-mail : <a href="mailto:sales@haulotte.com.au">sales@haulotte.com.au</a> <a href="http://www.haulotte.com.au">www.haulotte.com.au</a></p>		<p>HAULOTTE CHILE Panamerica Norte Altura Km 21,5 Colina (Cruce c/Lo Pinto) Santiago (RM) <b>TEL : + 562 2 3727630</b> E-mail : <a href="mailto:haulotte-chile@haulotte.com">haulotte-chile@haulotte.com</a> <a href="http://www.haulotte-chile.com">www.haulotte-chile.com</a></p>

# G - Other information

## 2.1 - CALIFORNIA WARNING

For electric (battery operated) machines

### CALIFORNIA



#### Proposition 65 Warning

Battery posts, terminals and related accessories contain lead and lead compounds, chemicals known to the State of California to cause cancer and reproductive harm. Batteries also contain other chemicals known to the State of California to cause cancer.

**WASH HANDS AFTER HANDLING.**

For more information go to  [www.P65Warnings.ca.gov](http://www.P65Warnings.ca.gov)

A

B

C

D

E

F

> G

H

I



# H - Intervention register

## 1 - Intervention register

The intervention register keeps a record of maintenance and repair work carried out inside or outside the maintenance programme.

***N.B.:-IN THE CASE OF A HAULOTTE SERVICES® INTERVENTION, THE QUALIFIED TECHNICIAN MUST INDICATE THE HAULOTTE SERVICES® INTERVENTION NUMBER.***

Date	Type of intervention	Number of hours	Intervenor	HAULOTTE Services® intervention number

A

B

C

D

E

F

G

**H**

I

