



A TEREX BRAND

Operator's Manual

GS™-2032

GS™-2632

CE

with
Maintenance
Information

Original Instructions
Fourth Edition
Fifth Printing
Part No. 1000034GT

Important

Read, understand and obey these safety rules and operating instructions before operating this machine. Only trained and authorized personnel shall be permitted to operate this machine. This manual should be considered a permanent part of your machine and should remain with the machine at all times. If you have any questions, contact us.

Contact Us:

Internet: www.genielift.com

E-mail: awp.techpub@terex.com

Contents

- Safety Rules..... 1
- Legend 9
- Controls..... 10
- Pre-operation Inspection..... 12
- Maintenance 14
- Function Tests 16
- Workplace Inspection..... 22
- Operating Instructions..... 23
- Transport and Lifting Instructions 29
- Decals 32
- Specifications..... 34

Copyright © 1997 Terex Corporation

First Edition: Seventeenth Printing, October 2002

Second Edition: First Printing, October 2003

Third Edition: Third Printing, July 2004

Fourth Edition: Fifth Printing, January 2018

Genie is a registered trademark of Terex South Dakota, Inc. in the U.S.A. and many other countries.

“GS” is a trademark of Terex South Dakota, Inc.

These machines comply with ANSI/SIA 92.6-1999.



Safety Rules



Danger

Failure to obey the instructions and safety rules in this manual will result in death or serious injury.

Do Not Operate Unless:

- You learn and practice the principles of safe machine operation contained in this operator's manual.
 - 1 Avoid hazardous situations.**

Know and understand the safety rules before going on to the next section.
 - 2 Always perform a pre-operation inspection.
 - 3 Always perform function tests prior to use.
 - 4 Inspect the workplace.
 - 5 Only use the machine as it was intended.
- You read, understand and obey the manufacturer's instructions and safety rules—safety and operator's manuals and machine decals.
- You read, understand and obey employer's safety rules and worksite regulations.
- You read, understand and obey all applicable governmental regulations.
- You are properly trained to safely operate the machine.

Safety Rules

⚠ Electrocutation Hazards

This machine is not electrically insulated and will not provide protection from contact with or proximity to electrical current.

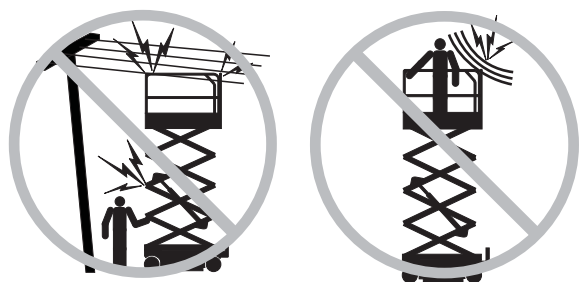

Maintain safe distances from electrical power lines and apparatus in accordance with applicable governmental regulations and the following chart.

Voltage Phase to Phase	Minimum Safe Approach Distance
0 to 300V	Avoid Contact
300V to 50KV	3.05 m
50KV to 200KV	4.60 m
200KV to 350KV	6.10 m
350KV to 500KV	7.62 m
500KV to 750KV	10.67 m
750KV to 1000KV	13.72 m

Allow for platform movement, electrical line sway or sag, and beware of strong or gusty winds.

Keep away from the machine if it contacts energized power lines. Personnel on the ground or in the platform must not touch or operate the machine until energized power lines are shut off.

Do not operate the machine during lightning or storms.

Do not use the machine as a ground for welding.

⚠ Tip-over Hazards

Occupants, equipment and materials shall not exceed the maximum platform capacity or the maximum platform capacity of the platform extension.

Models without capacity indicator:

Maximum capacity	
GS-2032	363 kg
GS-2632	227 kg

Models with capacity indicator:

The maximum capacity varies with the height of the platform.

Maximum capacity - GS-2032

Height of platform	Maximum capacity
6 m	363 kg
5.7 m	512 kg
3.5 m	693 kg
2.4 m	608 kg
1 m	454 kg

Maximum capacity - GS-2632

Height of platform	Maximum capacity
7.9 m	227 kg
6.4 m	442 kg
4.5 m	479 kg
2.8 m	409 kg
1 m	281 kg

Safety Rules



Do not raise the platform unless the machine is on a firm, level surface.



Do not depend on the tilt alarm as a level indicator. The tilt alarm sounds on the chassis only when the machine is on a severe slope.

If the tilt alarm sounds:

Lower the platform. Move the machine to a firm, level surface. If the tilt alarm sounds when the platform is raised, use extreme caution to lower the platform.

Do not alter or disable the limit switches.

Do not drive over 0.7 km/h with the platform raised.

Use extreme care and slow speeds while driving the machine in the stowed position across uneven terrain, debris, unstable or slippery surfaces and near holes and drop-offs.

Do not drive the machine on a slope that exceeds the slope and side slope rating of the machine. Slope rating applies to machines in the stowed position.

Maximum slope rating, stowed position	30% (17°)
--	-----------

Maximum side slope rating, stowed position	30% (17°)
---	-----------

Note: Slope rating is subject to ground conditions and adequate traction.

Do not use the platform controls to free a platform that is caught, snagged, or otherwise prevented from normal motion by an adjacent structure. All personnel must be removed from the platform before attempting to free the platform using the ground controls.



Do not push off or pull toward any object outside of the platform.

Maximum allowable manual force

GS-2032

CE - Indoor use only –2 person	400 N
CE - Outdoor use – 1 person	200 N

GS-2632

CE - Indoor use only –2 person	400 N
--------------------------------	-------

Do not alter or disable machine components that in any way affect safety and stability.

Do not replace items critical to machine stability with items of different weight or specification.

Safety Rules

Do not modify or alter an aerial work platform without prior written permission from the manufacturer. Mounting attachments for holding tools or other materials onto the platform, toeboards, or guard rail system can increase the weight in the platform and the surface area of the platform or the load.

Outdoor use: Do not raise the platform when wind speeds may exceed 12.5 m/s. If wind speeds exceed 12.5 m/s when the platform is raised, lower the platform and do not continue to operate the machine.

Indoor use: When raising the platform, follow ratings for allowable manual force and number of occupants on page 3.

Do not operate the machine in strong or gusty winds. Do not increase the surface area of the platform or the load. Increasing the area exposed to the wind will decrease machine stability.

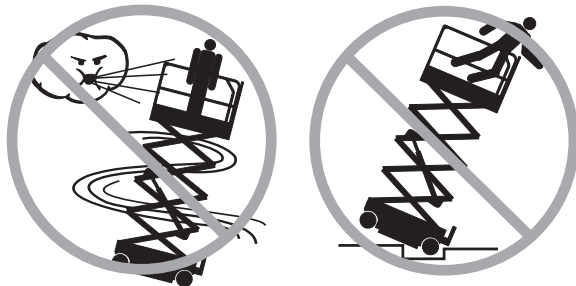

Do not drive the machine on or near uneven terrain, unstable surfaces or other hazardous conditions with the platform raised.



Do not place or attach fixed or overhanging loads to any part of this machine.



Do not place ladders or scaffolds in the platform or against any part of this machine.

Do not transport tools and materials unless they are evenly distributed and can be safely handled by person(s) in the platform.

Do not use the machine on a moving or mobile surface or vehicle.

Be sure all tires are in good condition, castle nuts are properly tightened and cotter pins are properly installed.

Do not use batteries that weigh less than the original equipment. Batteries are used as counterweight and are critical to machine stability. Each battery must weigh 30 kg.

Do not use the machine as a crane.

Do not push the machine or other objects with the platform.

Do not contact adjacent structures with the platform.

Do not tie the platform to adjacent structures.

Do not place loads outside the platform perimeter.

Do not operate the machine with the chassis trays open.

Safety Rules

▲ Fall Hazards

The guard rail system provides fall protection. If occupant(s) of the platform are required to wear personal fall protection equipment (PFPE) due to job site or employer rules, PFPE and its use shall be in accordance with the PFPE manufacturer's instructions and applicable governmental requirements. Use approved lanyard attachment point provided.



Do not sit, stand, or climb on the platform guard rails. Maintain a firm footing on the platform floor at all times.



Do not climb down from the platform when raised.

Keep the platform floor clear of debris.

Attach the platform entry chain or close the entry gate before operating.

Do not operate the machine unless the guard rails are properly installed and the entry is secured for operation.

▲ Collision Hazards

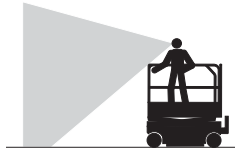

Be aware of limited sight distance and blind spots when driving or operating.

Be aware of extended platform position when moving the machine.

The machine must be on a level surface or secured before releasing the brakes.

Operators must comply with employer, job site, and governmental rules regarding use of personal protective equipment.



Check the work area for overhead obstructions or other possible hazards.



Be aware of crushing hazards when grasping the platform guard rail.

Observe and use color-coded direction arrows on the platform controls and the platform decal plate for drive and steer functions.

Safety Rules

No stunt driving or horseplay while operating a machine.



Do not lower the platform unless the area below is clear of personnel and obstructions.



Limit travel speed according to the condition of the ground surface, congestion, slope, location of personnel, and any other factors which may cause collision.

Do not operate a machine in the path of any crane or moving overhead machinery unless the controls of the crane have been locked out and/or precautions have been taken to prevent any potential collision.

▲ Crushing Hazard

Keep hands and limbs out of scissors.

Do not work under the platform or in the scissor links without the safety arm in place.

Use common sense and planning when operating the machine with the controller from the ground. Maintain safe distances between the operator, the machine and fixed objects.

▲ Component Damage Hazards

Do not use the machine as a ground for welding.

▲ Explosion and Fire Hazards

Do not operate the machine in hazardous locations or locations where potentially flammable or explosive gases or particles may be present.

Safety Rules

⚠ Damaged Machine Hazards

Do not use a damaged or malfunctioning machine.

Conduct a thorough pre-operation inspection of the machine and test all functions before each work shift. Immediately tag and remove from service a damaged or malfunctioning machine.

Be sure all maintenance has been performed as specified in this manual and the appropriate Genie service manual.

Be sure all decals are in place and legible.

Be sure the operator's, safety, and responsibilities manuals are complete, legible, and in the storage container located on the machine.

⚠ Bodily Injury Hazard

Do not operate the machine with a hydraulic oil or air leak. An air leak or hydraulic leak can penetrate and/or burn skin.

Improper contact with components under any cover will cause serious injury. Only trained maintenance personnel should access compartments. Access by the operator is only advised when performing a pre-operation inspection. All compartments must remain closed and secured during operation.

Decal Legend

Genie product decals use symbols, color coding and signal words to identify the following:



Safety alert symbol—used to alert personnel to potential personal injury hazards. Obey all safety messages that follow this symbol to avoid possible injury or death.



Red—used to indicate the presence of an imminently hazardous situation which, if not avoided, will result in death or serious injury.



Orange—used to indicate the presence of a potentially hazardous situation which, if not avoided, could result in death or serious injury.



Yellow with safety alert symbol—used to indicate the presence of a potentially hazardous situation which, if not avoided, may cause minor or moderate injury.



Yellow without safety alert symbol—used to indicate the presence of a potentially hazardous situation which, if not avoided, may result in property damage.



Green—used to indicate operation or maintenance information.

Safety Rules

▲ Battery Safety

Burn Hazards

Batteries contain acid. Always wear protective clothing and eye wear when working with batteries.

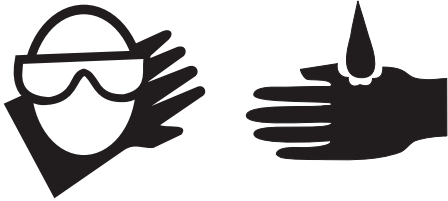

Avoid spilling or contacting battery acid. Neutralize battery acid spills with baking soda and water.

Do not expose the batteries or the charger to water or rain during charging.

Explosion Hazards



Keep sparks, flames, and lighted tobacco away from batteries. Batteries emit explosive gas.

The battery tray should remain open during the entire charging cycle.

Do not contact the battery terminals or the cable clamps with tools that may cause sparks.

Component Damage Hazard

Do not use any battery charger greater than 24V to charge the batteries.

Electrocution/Burn Hazards



Connect the battery charger to a grounded, AC 3-wire electrical outlet only.

Inspect daily for damaged cords, cables and wires. Replace damaged items before operating.

Avoid electrical shock from contact with battery terminals. Remove all rings, watches and other jewelry.

Tip-over Hazard

Do not use batteries that weigh less than the original equipment. Batteries are used as counterweight and are critical to machine stability. Each battery must weigh 30 kg.

Lifting Hazard

Use the appropriate number of people and proper lifting techniques when lifting batteries.

Legend

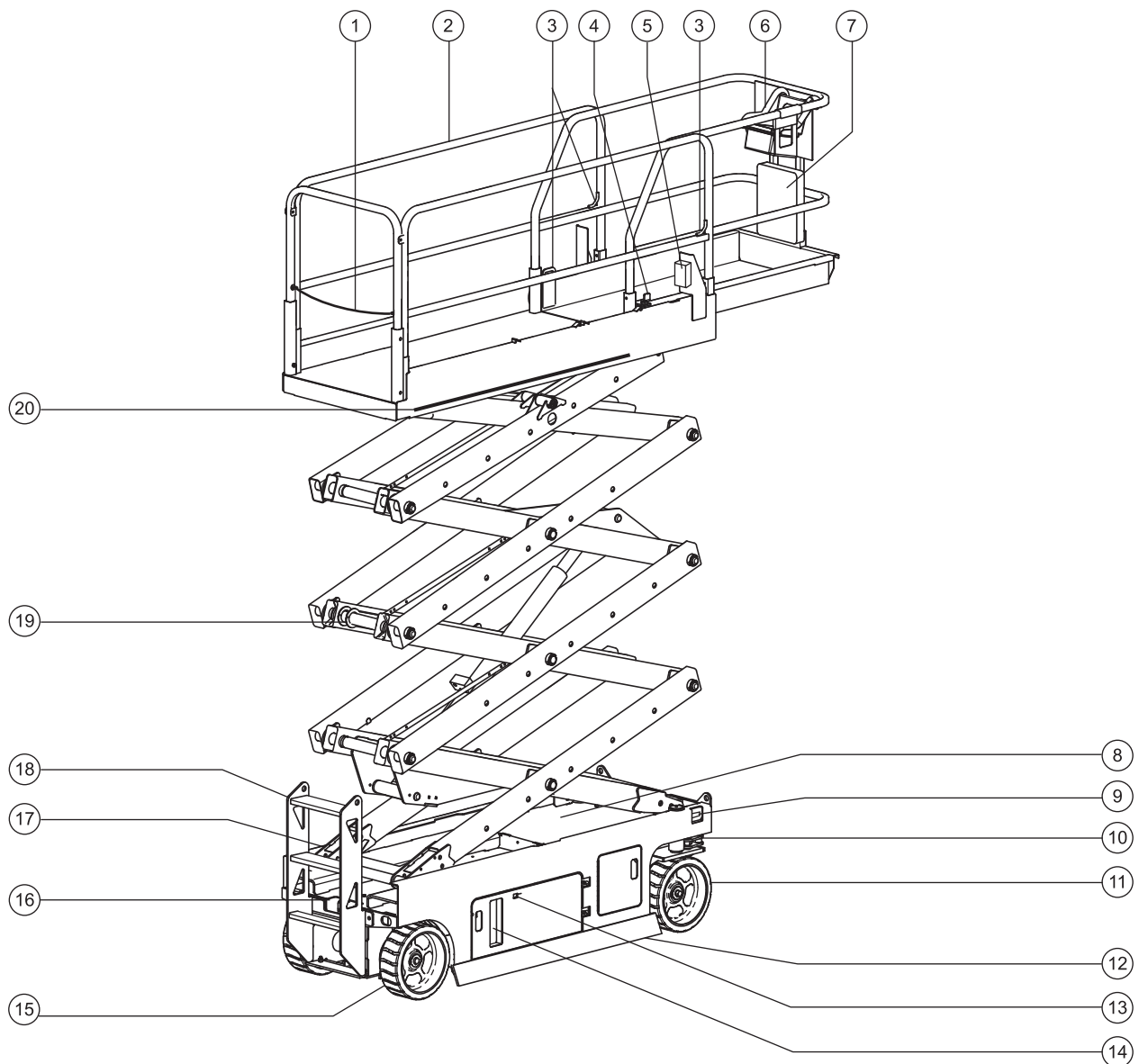

- | | | |
|------------------------------------|----------------------------|---|
| 1 Platform entry chain or gate | 8 Tilt alarm (under cover) | 16 Brake release pump knob and brake release knob |
| 2 Platform guard rails | 9 Auxiliary lowering lever | 17 Battery charger (on opposite side of machine) |
| 3 Lanyard anchorage points | 10 Transport tie-down | 18 Entry ladder / transport tie-down |
| 4 Platform extension release pedal | 11 Steer tire | 19 Safety arm |
| 5 GFCI outlet | 12 Pothole guard | 20 Capacity indicator (if equipped) |
| 6 Platform controls | 13 LCD readout | |
| 7 Manual storage container | 14 Ground controls | |
| | 15 Non-steer tire | |

Controls

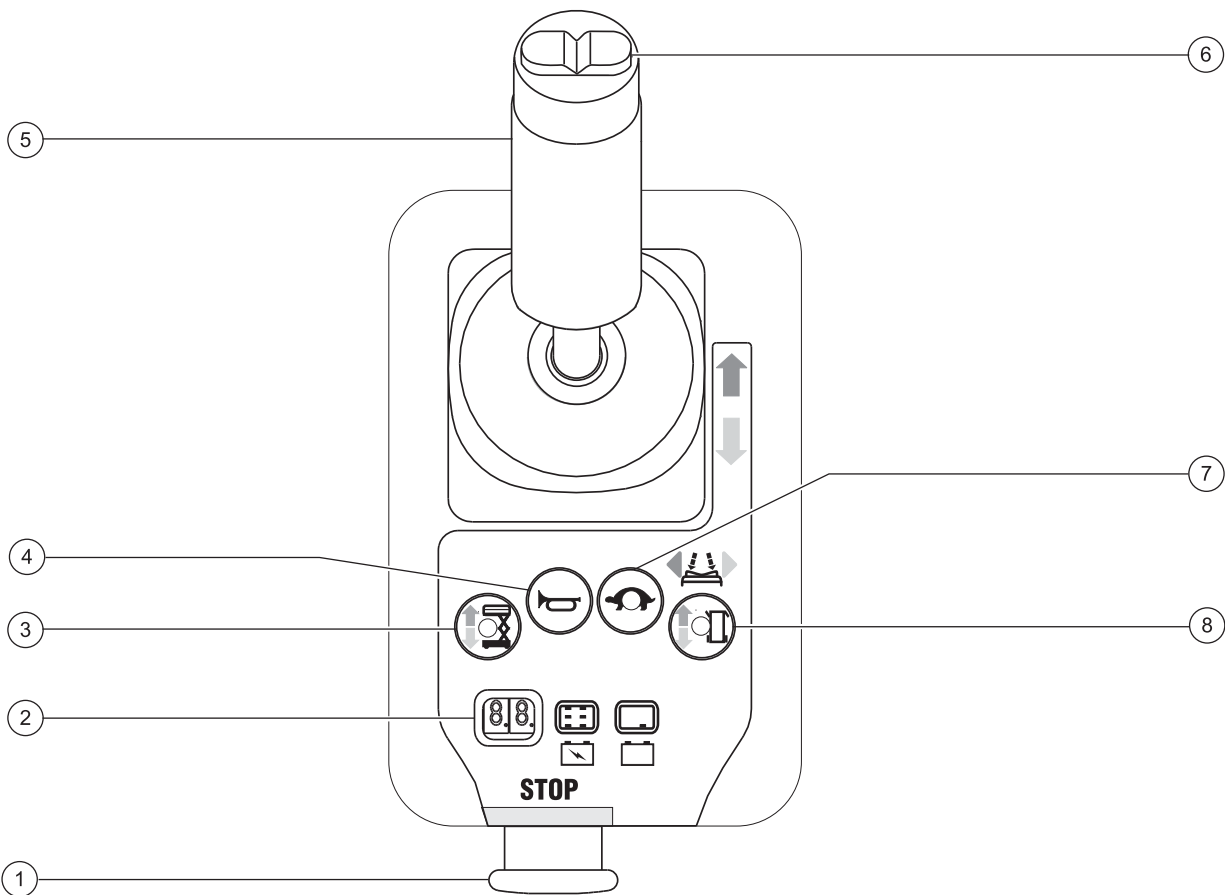

Platform Control Panel

- | | |
|---|---|
| 1 Red Emergency Stop button | 5 Proportional control handle and function enable switch for lift and drive functions |
| 2 LED diagnostic readout / battery charge indicator | 6 Thumb rocker switch for steer function |
| 3 Lift function select button | 7 Drive speed button |
| 4 Horn button | 8 Drive function select button |

Controls

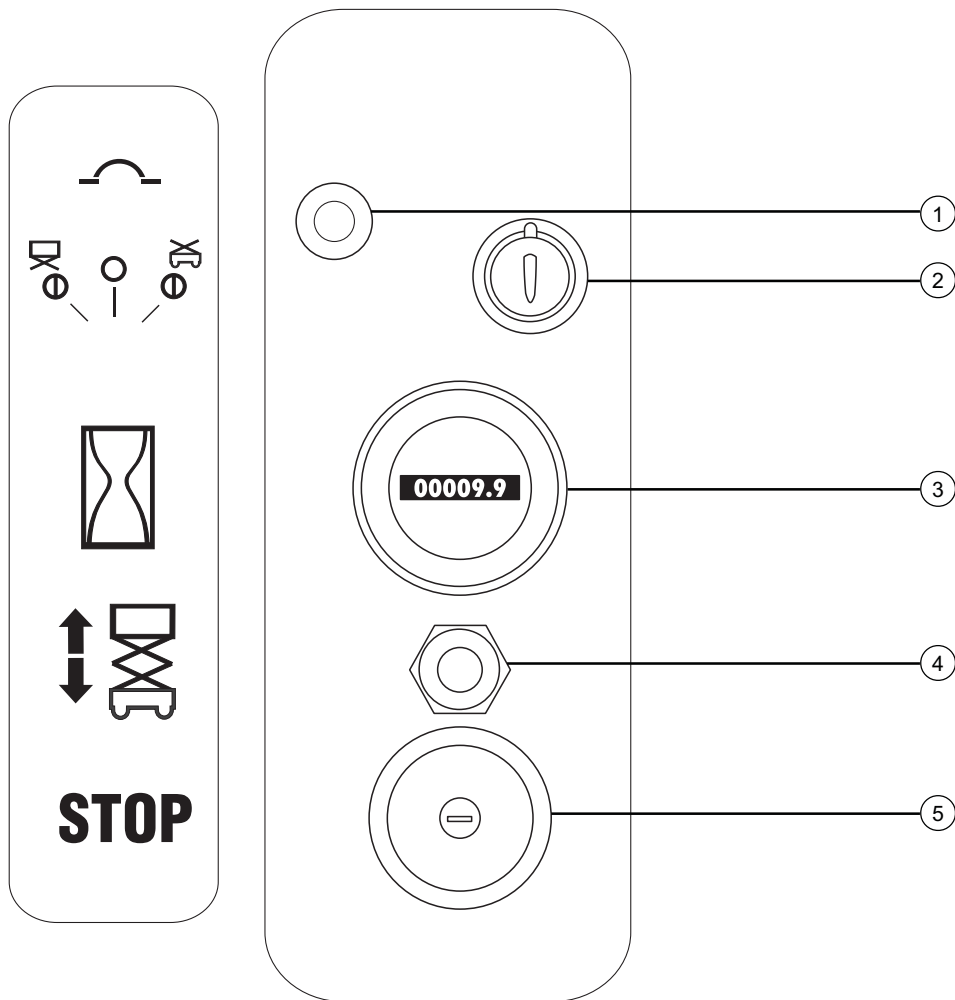

Ground Control Panel

- 1 7A breaker for electrical circuits
- 2 Key switch for platform/off/ground selection
- 3 Hour meter
- 4 Platform up/down toggle switch
- 5 Red Emergency Stop button

Pre-operation Inspection



Do Not Operate Unless:

- You learn and practice the principles of safe machine operation contained in this operator's manual.
 - 1 Avoid hazardous situations.
 - 2 **Always perform a pre-operation inspection.**
- Know and understand the pre-operation inspection before going on to the next section.**
 - 3 Always perform function tests prior to use.
 - 4 Inspect the workplace.
 - 5 Only use the machine as it was intended.

Pre-operation Inspection Fundamentals

It is the responsibility of the operator to perform a pre-operation inspection and routine maintenance.

The pre-operation inspection is a visual inspection performed by the operator prior to each work shift. The inspection is designed to discover if anything is apparently wrong with a machine before the operator performs the function tests.

The pre-operation inspection also serves to determine if routine maintenance procedures are required. Only routine maintenance items specified in this manual may be performed by the operator.

Refer to the list on the next page and check each of the items.

If damage or any unauthorized variation from factory delivered condition is discovered, the machine must be tagged and removed from service.

Repairs to the machine may only be made by a qualified service technician, according to the manufacturer's specifications. After repairs are completed, the operator must perform a pre-operation inspection again before going on to the function tests.

Scheduled maintenance inspections shall be performed by qualified service technicians, according to the manufacturer's specifications and the requirements listed in the responsibilities manual.

Pre-operation Inspection

Pre-operation Inspection

- Be sure that the operator's, safety, and responsibilities manuals are complete, legible and in the storage container located in the platform.
- Be sure that all decals are legible and in place. See Inspections section.
- Check for hydraulic oil leaks and proper oil level. Add oil if needed. See Maintenance section.
- Check for battery fluid leaks and proper fluid level. Add distilled water if needed. See Maintenance section.

Check the following components or areas for damage, improperly installed, or missing parts and unauthorized modifications:

- Electrical components, wiring, and electrical cables
- Hydraulic power unit, reservoir, hoses, fittings, cylinders and manifolds
- Hydraulic tank
- Battery pack and connections
- Drive motors
- Wear pads
- Tires and wheels
- Limit switches, alarms and horn
- Nuts, bolts and other fasteners
- Platform entry chain or gate
- Alarms and beacons (if equipped)
- Brake release components
- Platform overload components
- Safety arm

- Pothole guards
- Platform extension
- Scissor pins and retaining fasteners
- Platform control joystick
- Generator (if equipped)

Check entire machine for:

- Cracks in welds or structural components
- Dents or damage to machine
- Excessive rust, corrosion or oxidation
- Be sure that all structural and other critical components are present and all associated fasteners and pins are in place and properly tightened.
- Be sure side rails are installed and bolts are fastened.
- Be sure that the chassis trays are closed and latched and the batteries are properly connected.

Note: If the platform must be raised to inspect the machine, make sure the safety arm is in place. See Operating Instructions section.

Maintenance



Observe and Obey:

- ☑ Only routine maintenance items specified in this manual shall be performed by the operator.
- ☑ Scheduled maintenance inspections shall be completed by qualified service technicians, according to the manufacturer's specifications and the requirements specified in the responsibilities manual.

Maintenance Symbols Legend

NOTICE

The following symbols have been used in this manual to help communicate the intent of the instructions. When one or more of the symbols appear at the beginning of a maintenance procedure, it conveys the meaning below.



Indicates that tools will be required to perform this procedure.



Indicates that new parts will be required to perform this procedure.

Check the Hydraulic Oil Level



Maintaining the hydraulic oil at the proper level is essential to machine operation. Improper hydraulic oil levels can damage hydraulic components. Daily checks allow the inspector to identify changes in oil level that might indicate the presence of hydraulic system problems.

- 1 Be sure that the machine is on a firm, level surface, free of obstructions, with the platform in the stowed position.
- 2 Visually inspect the oil level in the hydraulic oil tank.
- ⊙ Result: The hydraulic oil level should be between the ADD and FULL marks on the tank.
- 3 Add oil as needed. Do not overfill.

Hydraulic oil specifications

Hydraulic oil type	Chevron Rando HD equivalent
--------------------	-----------------------------

Maintenance

Check the Batteries



Proper battery condition is essential to good machine performance and operational safety. Improper fluid levels or damaged cables and connections can result in component damage and hazardous conditions.

NOTICE This procedure does not need to be performed on machines with sealed or maintenance-free batteries.

⚠ WARNING Electrocutation hazard. Contact with hot or live circuits may result in death or serious injury. Remove all rings, watches and other jewelry.

⚠ WARNING Bodily injury hazard. Batteries contain acid. Avoid spilling or contacting battery acid. Neutralize battery acid spills with baking soda and water.

NOTICE Perform this test after fully charging the battery.

- 1 Put on protective clothing and eye wear.
- 2 Be sure that the battery cable connections are tight and free of corrosion.
- 3 Be sure that the battery hold-down brackets are in place and secure.
- 4 Remove the battery vent caps.
- 5 Check the battery acid level of each battery. If needed, replenish with distilled water to the bottom of the battery fill tube. Do not overfill.
- 6 Install the vent caps.

Scheduled Maintenance

Maintenance performed quarterly, annually and every two years must be completed by a person trained and qualified to perform maintenance on this machine according to the procedures found in the service manual for this machine.

Machines that have been out of service for more than three months must receive the quarterly inspection before they are put back into service.

Function Tests



Do Not Operate Unless:

- You learn and practice the principles of safe machine operation contained in this operator's manual.
 - 1 Avoid hazardous situations.
 - 2 Always perform a pre-operation inspection.
 - 3 Always perform function tests prior to use.**

Know and understand the function tests before going on to the next section.

- 4 Inspect the workplace.
- 5 Only use the machine as it was intended.

Function Test Fundamentals

The function tests are designed to discover any malfunctions before the machine is put into service. The operator must follow the step-by-step instructions to test all machine functions.

A malfunctioning machine must never be used. If malfunctions are discovered, the machine must be tagged and removed from service. Repairs to the machine may only be made by a qualified service technician, according to the manufacturer's specifications.

After repairs are completed, the operator must perform a pre-operation inspection and function tests again before putting the machine into service.

Function Tests

At the Ground Controls

- 1 Select a test area that is firm, level and free of obstruction.
 - 2 Be sure the batteries are connected.
 - 3 Pull out the platform and ground red Emergency Stop button to the on position.
 - 4 Turn the key switch to ground control.
 - 5 Observe the diagnostic LED readout.
- ⊙ Result: The LED should look like the picture at right.



Test Emergency Stop

- 6 Push in the ground red Emergency Stop button to the off position.
- ⊙ Result: No functions should operate.
- 7 Pull out the red Emergency Stop button to the on position.

Test the Up/Down Functions

The audible warnings on this machine and the standard horn all come from the same central alarm. The horn is a constant tone. The descent alarm sounds at 60 beeps per minute. The alarm that goes off when the pothole guards have not deployed sounds at 300 beeps per minute. The alarm that goes off when the machine is not level sounds at 600 beeps per minute. An optional automotive-style horn is also available.

- 8 Activate the up function.
- ⊙ Result: The platform should raise.
- 9 Activate the down function.
- ⊙ Result: The platform should lower. The descent alarm should sound while the platform is lowering.

Test Auxiliary Lowering

- 10 Activate the up function and raise the platform approximately 60 cm.
 - 11 Pull the auxiliary lowering knob.
- ⊙ Result: The platform should lower. The descent alarm will not sound.
- 12 Turn the key switch to platform control.

Function Tests

At the Platform Controls

Test Emergency Stop

- 13 Push in the platform red Emergency Stop button to the off position.

⊙ Result: No functions should operate.

Test the Horn

- 14 Pull out the red Emergency Stop button to the on position.

- 15 Press the horn button.

⊙ Result: The horn should sound.

Test the Function Enable Switch

- 16 Do not hold the function enable switch on the control handle.

- 17 Slowly move the control handle in the direction indicated by the blue arrow, then in the direction indicated by the yellow arrow.

⊙ Result: No functions should operate.

Test the Up/Down Functions

- 18 Press the lift function select button.

- 19 Press and hold the function enable switch on the control handle.



- 20 Slowly move the control handle in the direction indicated by the blue arrow.

⊙ Result: The platform should raise. The pothole guards should deploy.

- 21 Release the control handle.

⊙ Result: The platform should stop raising.

- 22 Press and hold the function enable switch. Slowly move the control handle in the direction indicated by the yellow arrow.

⊙ Result: The platform should lower. The descent alarm should sound while the platform is lowering.

Function Tests

Test the Steering

Note: When performing the steer and drive function tests, stand in the platform facing the steer end of the machine.

23 Press the drive function select button.

24 Press and hold the function enable switch on the control handle.



25 Press the thumb rocker switch on top of the control handle in the direction indicated by the blue triangle on the control panel.

⊙ Result: The steer wheels should turn in the direction indicated by the blue triangle.

26 Press the thumb rocker switch on top of the control handle in the direction indicated by the yellow triangle, on the control panel.

⊙ Result: The steer wheels should turn in the direction indicated by the yellow triangle.

Test Drive and Braking

27 Press and hold the function enable switch on the control handle.

28 Slowly move the control handle in the direction indicated by the blue arrow on the control panel until the machine begins to move, then return the control handle to the center position.

⊙ Result: The machine should move in the direction that the blue arrow points on the control panel, then come to an abrupt stop.

29 Slowly move the control handle in the direction indicated by the yellow arrow on the control panel until the machine begins to move, then return the control handle to the center position.

⊙ Result: The machine should move in the direction that the yellow arrow points on the control panel, then come to an abrupt stop.

Note: The brakes must be able to hold the machine on any slope it is able to climb.

Function Tests

Test the Tilt Sensor Operation

Note: Perform this test from the ground with the platform controller. Do not stand in the platform.

- 30 Fully lower the platform.
- 31 Place a 2x4 or similar piece of wood under both wheels on one side and drive the machine up onto them.
- 32 Raise the platform approximately 2.1 m from the ground.
 - ⦿ Result: The platform should stop and the tilt alarm will sound at 600 beeps per minute.
- 33 Move the drive control handle in the direction indicated by the blue arrow, then move the drive control handle in the direction indicated by the yellow arrow.
 - ⦿ Result: The drive function should not work in either direction.
- 34 Lower the platform and remove both pieces of wood.

Test Limited Drive Speed

- 35 Press the lift function select button.
- 36 Press and hold the function enable switch on the control handle. Raise the platform approximately 1.2 m from the ground.
 - ⦿ Result: The pothole guards should deploy.
- 37 Press the drive function select button.
- 38 Press and hold the function enable switch on the control handle. Slowly move the control handle to full drive position.
 - ⦿ Result: The maximum achievable drive speed with the platform raised should not exceed 23 cm per second.
- 39 If the drive speed with the platform raised exceeds 23 cm per second, immediately tag and remove the machine from service.

Function Tests

Test the Pothole Guards

Note: The pothole guards should automatically deploy when the platform is raised. The pothole guards activate two limit switches which control the machine drive speed. If the pothole guards do not deploy and the platform is raised above 1.8 m, an alarm sounds and the machine will not drive.

40 Raise the platform.

⊙ Result: When the platform is raised 1.2 m from the ground, the pothole guards should deploy.

41 Press on the pothole guards on one side, and then the other.

⊙ Result: The pothole guards should not move.

42 Lower the platform.

⊙ Result: The pothole guards should return to the stowed position.

43 Place a 2x4 or similar piece of wood under a pothole guard.

44 Raise the platform.

⊙ Result: Before the platform is raised 2.1 m from the ground, an alarm should sound and the drive function should not work.

45 Lower the platform.

46 Remove the 2x4 or similar piece of wood.

Workplace Inspection



Do Not Operate Unless:

- You learn and practice the principles of safe machine operation contained in this operator's manual.
 - 1 Avoid hazardous situations.
 - 2 Always perform a pre-operation inspection.
 - 3 Always perform function tests prior to use.
 - 4 **Inspect the workplace.**
Know and understand the workplace inspection before going on to the next section.
 - 5 Only use the machine as it was intended.

Workplace Inspection Fundamentals

The workplace inspection helps the operator determine if the workplace is suitable for safe machine operation. It should be performed by the operator prior to moving the machine to the workplace.

It is the operator's responsibility to read and remember the workplace hazards, then watch for and avoid them while moving, setting up, and operating the machine.

Workplace Inspection Checklist

Be aware of and avoid the following hazardous situations:

- drop-offs or holes
- bumps, floor obstructions, or debris
- sloped surfaces
- unstable or slippery surfaces
- overhead obstructions and high voltage conductors
- hazardous locations
- inadequate surface support to withstand all load forces imposed by the machine
- wind and weather conditions
- the presence of unauthorized personnel
- other possible unsafe conditions

Operating Instructions



Do Not Operate Unless:

- You learn and practice the principles of safe machine operation contained in this operator's manual.
 - 1 Avoid hazardous situations.
 - 2 Always perform a pre-operation inspection.
 - 3 Always perform function tests prior to use.
 - 4 Inspect the workplace.
 - 5 **Only use the machine as it was intended.**

Fundamentals

The Operating Instructions section provides instructions for each aspect of machine operation. It is the operator's responsibility to follow all the safety rules and instructions in the operator's, safety, and responsibilities manuals.

Using the machine for anything other than lifting personnel, along with their tools and materials, to an aerial work site is unsafe and dangerous.

Only trained and authorized personnel should be permitted to operate a machine. If more than one operator is expected to use a machine at different times in the same work shift, they must all be qualified operators and are all expected to follow all safety rules and instructions in the operator's, safety, and responsibilities manuals. That means every new operator should perform a pre-operation inspection, function tests, and a workplace inspection before using the machine.

Operating Instructions

Emergency Stop

Push in the red Emergency Stop button to the off position at the ground controls or the platform controls to stop all functions.

Repair any function that operates when either red Emergency Stop button is pushed in.

Auxiliary Lowering

- 1 Pull the auxiliary lowering knob.

Operation from Ground

- 1 Turn the key switch to ground control.
- 2 Pull out both ground and platform red Emergency Stop buttons to the on position.
- 3 Be sure the battery pack is connected before operating the machine.

To Position Platform

- 1 Move the up/down toggle switch according to the markings on the control panel.

Drive and steer functions are not available from the ground controls.

Operation from Platform

- 1 Turn the key switch to platform control.
- 2 Pull out both ground and platform red Emergency Stop buttons to the on position.
- 3 Be sure the battery pack is connected before operating the machine.

To Position Platform

- 1 Press the lift function select button.
- 2 Press and hold the function enable switch on the control handle.
- 3 Move the control handle in the direction indicated by the markings on the control panel.



To Steer

- 1 Press the drive function select button.
- 2 Press and hold the function enable switch on the control handle.
- 3 Turn the steer wheels with the thumb rocker switch located on the top of the control handle.

To Drive

- 1 Press the drive function select button.
- 2 Press and hold the function enable switch on the control handle.
- 3 Increase speed: Slowly move the control handle off center.
Decrease speed: Slowly move the control handle toward center.



Stop: Return the control handle to center or release the function enable switch.

Use the color-coded direction arrows on the platform controls and on the platform to identify the direction the machine will travel.

Machine travel speed is restricted when the platform is raised.

Battery condition will affect machine performance. Machine drive speed and function speed will drop when the battery level indicator is flashing.

Operating Instructions

To reduce drive speed

The drive controls can operate in two different drive speed modes. When the drive speed button light is on, slow drive speed mode is active. When the button light is off, fast drive speed mode is active.



Press the drive speed button to select the desired drive speed.

▲ Driving on a slope

Determine the slope and side slope ratings for the machine and determine the slope grade.



Maximum slope rating, stowed position:	30% (17°)
---	-----------

Maximum side slope rating, stowed position:	30% (17°)
--	-----------

Note: Slope rating is subject to ground conditions and adequate traction.

Press the drive speed button to the fast drive speed mode.

To determine the slope grade:

Measure the slope with a digital inclinometer OR use the following procedure.

You will need:

- carpenter's level
- straight piece of wood, at least 1 m long
- tape measure

Lay the piece of wood on the slope.

At the downhill end, lay the level on the top edge of the piece of wood and lift the end until the piece of wood is level.

While holding the piece of wood level, measure the vertical distance from the bottom of the piece of wood to the ground.

Divide the tape measure distance (rise) by the length of the piece of wood (run) and multiply by 100.

Example:

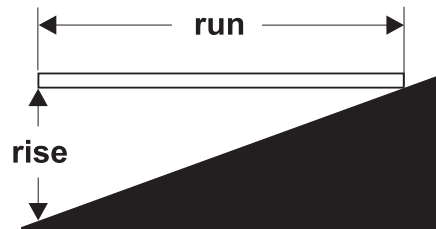

Piece of wood = 3.6 m

Run = 3.6 m

Rise = 0.3 m

$0.3 \text{ m} \div 3.6 \text{ m} = 0.083 \times 100 = 8.3\% \text{ grade}$

If the slope exceeds the maximum uphill, downhill or side slope rating, then the machine must be winched or transported up or down the slope. See Transport and Lifting section.

Operating Instructions

Error indicator readout



If the LED diagnostic readout displays an error code, such as LL, push in and pull out the red Emergency Stop button to reset the system.

To Extend and Retract Platform

- 1 Step on the platform extension release pedal on the platform toeboard.
- 2 Grasp the platform guard rails and carefully push to extend the platform to the mid-position stop.
- 3 Step on the release pedal again and push to fully extend the platform.

Do not stand on the platform extension while trying to extend it.

- 4 Step on the platform extension release pedal and pull to retract the platform to the midposition stop. Step again to fully retract the platform.

Operation from Ground with Controller

Maintain safe distances between the operator, machine and fixed objects.

Be aware of the direction the machine will travel when using the controller.

Platform Overload

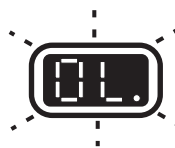

Flashing OL in the LED diagnostic readout indicates the platform is overloaded and no functions will operate. An alarm will sound.

- 1 Push in the red Emergency Stop button to the off position.
- 2 Remove weight from the platform.
- 3 Pull out the red Emergency Stop button to the on position.

Battery Level Indicator

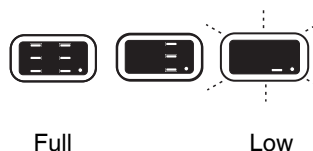

Full

Low

Use the LED diagnostic readout to determine the battery level.

Personal Fall Protection

Personal fall protection equipment (PFPE) is not required when operating this machine. If PFPE is required by job site or employer rules, the following shall apply:

All PFPE must comply with applicable governmental regulations and must be inspected and used in accordance with the manufacturer's instructions.

Operating Instructions

After Each Use

- 1 Select a safe parking location—firm level surface, clear of obstruction and traffic.
- 2 Lower the platform.
- 3 Turn the key switch to the off position and remove the key to secure from unauthorized use.
- 4 Chock the wheels.
- 5 Charge the batteries.

How to Use the Safety Arm

- 1 Raise the platform approximately 2.4 m from the ground.
- 2 Rotate the safety arm away from the machine and let it hang down.
- 3 Lower the platform until the safety arm rests securely on the link. Keep clear of the safety arm when lowering the platform.

Operating Instructions



Battery and Charger Instructions

Observe and Obey:

- Do not use an external charger or booster battery.
- Charge the battery in a well-ventilated area.
- Use proper AC input voltage for charging as indicated on the charger.
- Use only a Genie authorized battery and charger.

To Charge Battery

- 1 Be sure the batteries are connected before charging the batteries.
- 2 Open the battery compartment. The compartment should remain open for the entire charging cycle.

Maintenance-free batteries

- 1 Connect the battery charger to a grounded AC circuit.
- 2 The charger will indicate when the battery is fully charged.

Standard Batteries

- 1 Remove the battery vent caps and check the battery acid level. If necessary, add only enough distilled water to cover the plates. Do not overfill prior to the charge cycle.
- 2 Replace the battery vent caps.
- 3 Connect the battery charger to a grounded AC circuit.
- 4 The charger will indicate when the battery is fully charged.
- 5 Check the battery acid level when the charging cycle is complete. Replenish with distilled water to the bottom of the fill tube. Do not overfill.

Dry Battery Filling and Charging Instructions

- 1 Remove the battery vent caps and permanently remove the plastic seal from the battery vent openings.
- 2 Fill each cell with battery acid (electrolyte) until the level is sufficient to cover the plates.

Do not fill to maximum level until the battery charge cycle is complete. Overfilling can cause the battery acid to overflow during charging. Neutralize battery acid spills with baking soda and water.

- 3 Install the battery vent caps.
- 4 Charge the battery.
- 5 Check the battery acid level when the charging cycle is complete. Replenish with distilled water to the bottom of the fill tube. Do not overfill.

Transport and Lifting Instructions



Observe and Obey:

- ☑ Common sense and planning must be applied to control the movement of the machine when lifting it with a crane or forklift.
- ☑ The transport vehicle must be parked on a level surface.
- ☑ The transport vehicle must be secured to prevent rolling while the machine is being loaded.
- ☑ Be sure the vehicle capacity, loading surfaces and chains or straps are sufficient to withstand the machine weight. Genie lifts are very heavy relative to their size. See the serial label for the machine weight. See the inspections section for the serial label location.
- ☑ The machine must be on a level surface or secured before releasing the brakes.
- ☑ Do not allow the rails to fall when the snap pins are removed. Maintain a firm grasp on the rails when the rails are lowered.
- ☑ Do not drive the machine on a slope that exceeds the slope or side slope rating. See Driving on a Slope in the Operating Instructions section.
- ☑ If the slope of the transport vehicle bed exceeds the maximum slope rating, the machine must be loaded and unloaded using a winch as described in the brake release operation.

Brake Release Operation



- 1 Chock the wheels to prevent the machine from rolling.
- 2 Be sure the winch line is properly secured to the drive chassis tie points and the path is clear of all obstructions.
- 3 Push in the black brake release knob to open the brake valve.
- 4 Pump the red brake release pump knob.

After the machine is loaded:

- 1 Chock the wheels to prevent the machine from rolling.
- 2 Press the drive function select button. Press and hold the function enable switch on the control handle. Move the control handle off center to reset the brakes.

Towing the Genie GS-2032 and the GS-2632 is not recommended. If the machine must be towed, do not exceed 3.2 km/h.

Transport and Lifting Instructions



Observe and Obey:

- ☑ Only qualified riggers should rig and lift the machine.
- ☑ Only qualified forklift operators should lift the machine with a forklift.
- ☑ Be sure the crane capacity, loading surfaces and straps or lines are sufficient to withstand the machine weight. See the serial label for the machine weight.

Lifting Instructions

Fully lower the platform. Be sure the extension deck, controls and component trays are secure. Remove all loose items on the machine.

Determine the center of gravity of your machine using the table and the picture on this page.

Attach the rigging only to the designated lifting points on the machine. There are two 2.5 cm holes on the front of the machine and two holes in the ladder for lifting.

Adjust the rigging to prevent damage to the machine and to keep the machine level.

Center of gravity	X Axis	Y Axis
GS-2032	80.9 cm	53.9 cm
GS-2632	82.2 cm	59.3 cm

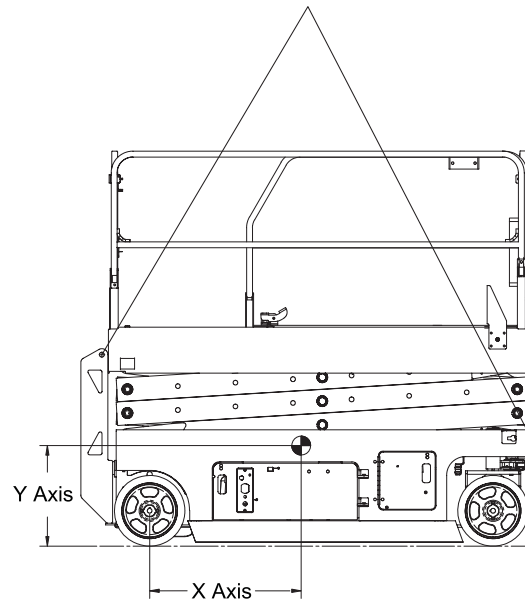

Transport and Lifting Instructions

Securing to Truck or Trailer for Transit

Always use the extension deck lock when the machine is transported.

Turn the key switch to the off position and remove the key before transporting.

Inspect the entire machine for loose or unsecured items.

Use chains or straps of ample load capacity.

Use a minimum of 2 chains or straps.

Adjust the rigging to prevent damage to the chains.

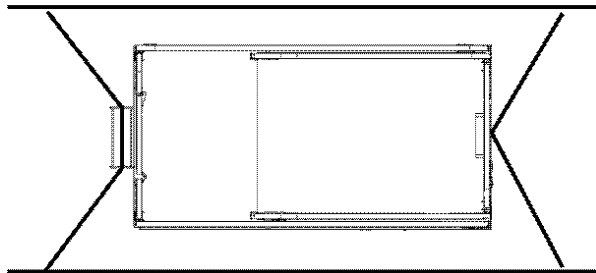
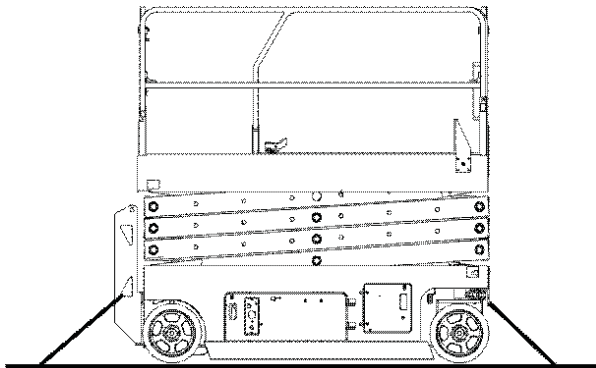

Decals

Decal Inspection

Use the pictures on the next page to verify that all decals are legible and in place.

Below is a numerical list with quantities and descriptions.

Part No.	Decal Description	Qty
28174	Label – Power to Platform, 230V	2
28235	Label – Power to Platform, 115V	2
40434	Label – Lanyard Anchorage Point	3
43618	Label – Directional Arrows	2
43658	Label – Power to Charger, 230V	1
44980	Label – Power to Charger, 115V	1
44981	Label – Air Line to Platform, 110 PSI	2
52475	Label – Transport Tie-down	3
62055	Cosmetic – Genie GS-2032	2
65058	Label - Controller Identification	1
72973	Cosmetic – Genie GS-2632	2
82472	Label – Crushing Hazard	1
82474	Label – Use Safety Chock	2
82476	Label – Electrocutation Hazard	2
82481	Label – Battery/Charger Safety	1
82482	Label – Emergency Lowering	1
82487	Label – Read the Manual	2
82495	Label – Brake Release Safety and Operating Instructions	1
82497	Label – Manual Force, 200 N Outdoors/400 N Indoors	1

Part No.	Decal Description	Qty
82502	Label - LED Diagnostic Readout	1
82560	Label – Skin Injection Hazard	1
82562	Label – Crushing Hazard	4
82567	Ground Control Panel	1
97582	Label – Manual Force, 400 N, Indoor Use Only	1
97683	Label - Capacity Indicator - GS-2032	1
97684	Label - Capacity Indicator - GS-2632	1
97685	Danger - Maximum Capacity, GS-2032	1
97686	Danger - Maximum Capacity, GS-2632	1
97692	Label – Wheel Load, GS-2032	4
97693	Label – Wheel Load, GS-2632	4
97719	Label – Safety Arm	1
97772	Platform Control Panel	1
133241	Label - Maximum Capacity, GS-2032	1
133242	Label - Maximum Capacity, GS-2632	1

Decals

Ground Controls Side

Battery Side

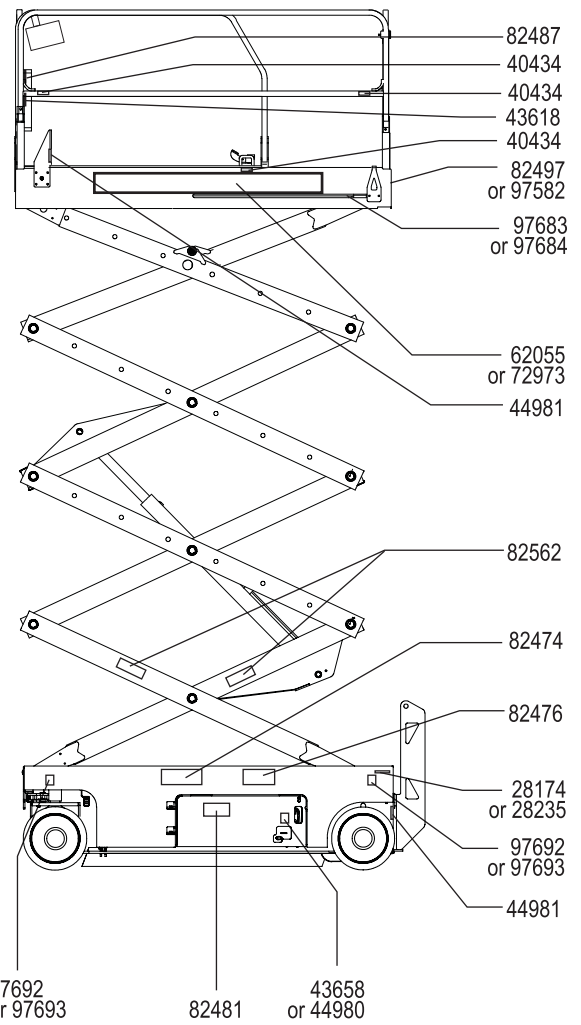
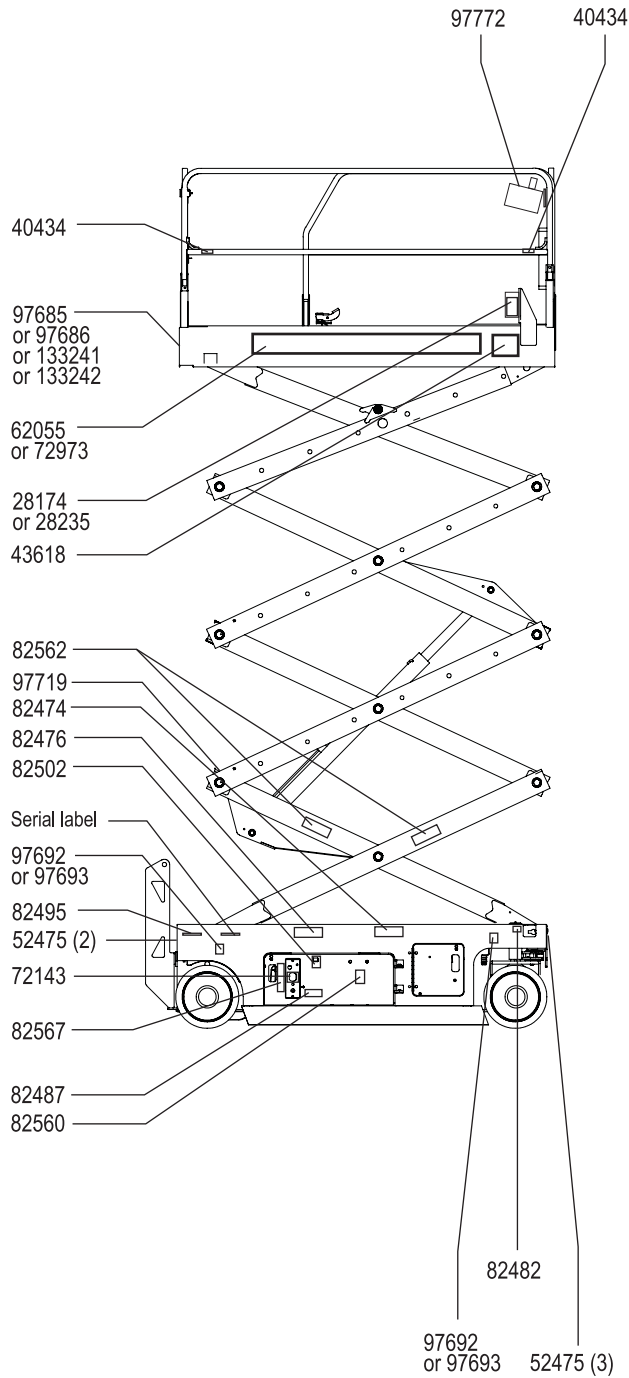

Specifications

Model	GS-2032
Height, working maximum	8.1 m
Height, platform maximum	6.1 m
Height, stowed maximum	2.13 m
Height, stowed maximum, rails folded	1.78 m
Height, guard rails	1.1 m
Width	81.3 cm
Length, stowed	2.44 m
Length, platform extended	3.33 m
Maximum load capacity Models without capacity indicator:	363 kg
Maximum load capacity Models with capacity indicator:	363 - 693 kg
Maximum wind speed	
Indoor use	0 m/s
Outdoor use	12.5 m/s
Wheelbase	1.85 m
Turning radius (outside)	2.12 m
Turning radius (inside)	0 cm
Ground clearance	8.9 cm
Ground clearance Pothole guards deployed	1.9 cm
Weight	See Serial Label
Machine weights vary with option configurations.	
Airborne noise emissions	<70 dB
Maximum sound level at normal operating workstations (A-weighted)	
Power source	4 Batteries, 6V 225AH
System voltage	24V
Controls	Proportional

AC outlet in platform	Standard
Maximum hydraulic pressure (functions)	241.3 bar
Tire size	15 x 5 x 11.25 in

Platform dimensions

Length x width	2.26 m x 79.4 cm
Platform extension length	99 cm

Maximum slope rating, stowed position	30% (17°)
--	-----------

Maximum side slope rating, stowed position	30% (17°)
---	-----------

Note: Slope rating is subject to ground conditions and adequate traction.

Drive speeds

Stowed, maximum	3.5 km/h
Platform raised, maximum	0.8 km/h 12.2 m/54.5 sec

Floor loading information

Tire load maximum	802 kg
Tire contact pressure	8.29 kg/cm ² 813 kPa
Occupied floor pressure	1306 kg/m ² 12.81 kPa

Note: Floor loading information is approximate and does not incorporate different option configurations. It should be used only with adequate safety factors.

Continuous improvement of our products is a Genie policy. Product specifications are subject to change without notice or obligation.

Specifications

Model	GS-2632
Height, working maximum	9.9 m
Height, platform maximum	7.9 m
Height, stowed maximum	2.26 m
Height, stowed maximum, rails folded	1.91 m
Platform height, stowed maximum	1.16 m
Height, guard rails	1.1 m
Width	81.3 cm
Length, stowed	2.44 m
Length, platform extended	3.33 m
Platform extension length	89 cm
Platform dimensions (length x width)	226 x 81 cm
Maximum load capacity Models without capacity indicator:	227 kg
Maximum load capacity Models with capacity indicator:	227 - 479 kg
Maximum wind speed	
Indoor only	0 m/s
Wheelbase	1.85 m
Turning radius (outside)	2.12 m
Turning radius (inside)	0 cm
Ground clearance	8.9 cm
Ground clearance Pothole guards deployed	1.9 cm
Weight	See Serial Label
Machine weights vary with option configurations.	
Airborne noise emissions	<70 dB
Maximum sound level at normal operating workstations (A-weighted)	
Power source	4 Batteries, 6V 225AH
Controls	Proportional
System voltage	24V

AC outlet in platform	Standard
Maximum hydraulic pressure (functions)	241.3 bar
Tire size	15 x 5 x 11.25 in
Vibration value does not exceed 2.5 m/s ²	

Platform dimensions

Length x width	2.26 m x 79.4 cm
Platform extension length	99 cm

Maximum slope rating, stowed position	30% (17°)
--	-----------

Maximum side slope rating, stowed position	30% (17)
---	----------

Note: Slope rating is subject to ground conditions and adequate traction.

Drive speeds

Stowed, maximum	3.5 km/h
Platform raised, maximum	0.8 km/h 12.2 m/54 sec

Floor loading information

Tire load maximum	830 kg
Tire contact pressure	12.87 kg/cm ² 1262 kPa
Occupied floor pressure	1187 kg/m ² 11.65 kPa

Note: Floor loading information is approximate and does not incorporate different option configurations. It should be used only with adequate safety factors.

Continuous improvement of our products is a Genie policy. Product specifications are subject to change without notice or obligation.

California Proposition 65



Operating, servicing and maintaining this equipment can expose you to chemicals including engine exhaust, carbon monoxide, phthalates, and lead, which are known to the State of California to cause cancer and birth defects or other reproductive harm. These chemicals can be emitted from or contained in other various parts and systems, fluids and some component wear by-products. To minimize exposure, avoid breathing exhaust, do not idle the engine except as necessary, service your equipment and vehicle in a well-ventilated area and wear gloves or wash your hands frequently when servicing your equipment or vehicle and after operation. For more information go to www.P65Warnings.ca.gov/passenger-vehicle.