

CE

IT

90

USE AND MAINTENANCE HANDBOOK



IT 6390

IT 8290

IT10090



MUM_IT90_GB_R03 06/2008

Here below you can find the picture regarding the metal plate attached on the machine and concerning identification data; it is advised to full in the serial number of the corresponding model in order to bind this manual to the specific machine.

iteco 		PIATTAFORME AEREE SEMOVENTI		CE	
VIA S.FRANCESCO D'ASSISI 8 - 46020 PEGOGNAGA (MN) ITALY - TEL. +39 0376 554011 - www.itecolift.it					
MODELLO	IT6390	MASSA	kg	2065	
MATRICOLA		BATTERIA	V/Ah	24/250	
ANNO DI COSTRUZIONE		PRESSIONE MAX	bar	135	
POTENZA	kw	3,8			
A00031IT					

iteco 		PIATTAFORME AEREE SEMOVENTI		CE	
VIA S.FRANCESCO D'ASSISI 8 - 46020 PEGOGNAGA (MN) ITALY - TEL. +39 0376 554011 - www.itecolift.it					
MODELLO	IT8290	MASSA	kg	2530	
MATRICOLA		BATTERIA	V/Ah	24/250	
ANNO DI COSTRUZIONE		PRESSIONE MAX	bar	175	
POTENZA	kw	3,8			
A00031IT					

iteco 		PIATTAFORME AEREE SEMOVENTI		CE	
VIA S.FRANCESCO D'ASSISI 8 - 46020 PEGOGNAGA (MN) ITALY - TEL. +39 0376 554011 - www.itecolift.it					
MODELLO	IT10090	MASSA	kg	3120	
MATRICOLA		BATTERIA	V/Ah	24/300	
ANNO DI COSTRUZIONE		PRESSIONE MAX	bar	175	
POTENZA	kw	3,8			
A00031IT					

IMPORTANT

A suitable working safety is very important in order to avoid serious injuries for the operator himself and for the others persons, therefore it is compulsory to carefully read and well-understand this handbook to know the exact and essential instructions for the use of the machine and the maintenance operations.

This handbook is to be considered as an integral part of the machine and it should always remain on the platform.

Only qualified and skilled operators could use this machine.

ITECO S.p.a.
46020 PEGOGNAGA (MN) ITALIA
Via S. Francesco D'Assisi, 8
Tel. +39 0376.554011
Fax +39 0376.559855
E-mail: info@itecolift.it - www.itecolift.it

Summary

Foreseen conditions of use	8
After-sale service	10
Spare-part service	10
Structure of the handbook	10
General recommendations - safety rules	11
Safety systems	11
Adhesive labels and plates	11
Operator's requirements	12
Not allowable operations	14
To minimize hazards	16
Main components	19
Identification	20
Description	21
Standard equipment	24
Optional	24
Technical features	25
Overall dimensions	26
Plates and adhesive labels	27
Operating principles	28
Electric circuit	28
Hydraulic circuit	28
Electronic circuit	29
Safety systems	30
Microswitches	30
SQ1 Microswitch	30
SQ5 Microswitch	30
SQ3 Microswitch	31
SQ6A - SQ6B Microswitches	31
Antishearing operations	32
Battery connection plug	32
Emergency stop push button	33
Flatness indicator	33
Load limiting device	34
Safety belt connection	34
Checking before use	35
Visual checking	35

Operating check	36
Controls and Action.....	38
Control panels	39
Ground control panel	39
Platform control panel.....	40
Operations from ground.....	41
Starting and enabling ground controls.....	41
Platform lifting/lowering	42
Starting and enabling platform controls.....	42
Emergency stop	43
Overload pilot light	44
Battery charge indicator - Hour counter.....	44
Diagnostic.....	44
Operations from platform	45
Traction.....	46
Steering.....	49
Platform lifting/lowering	50
Emergency stop	51
Platform extension	52
Railing overturning.....	53
Machine stopping	55
Emergencies.....	56
Overload.....	56
Machine unstable	57
Protections against overturning.....	57
General diagnostic	58
Diagnostic display	58
Emergency lowering.....	59
Battery recharge	61
Before the charge.....	62
Charge start.....	62
Charge end.....	63
Battery disposal.....	64
Lifting and transportation	64
Storage.....	64
Emergency towing.....	65
Disposal and scrapping.....	65
220V Line.....	66
Rotating beacons	66
110V Line.....	67
Battery charger kit 110V.....	67

Machine cleaning	68
Maintenance devices	69
Safety rest.....	69
Battery connection plug	70
Maintenance summary table.....	71
Check oil level	72
Electrolyte level check.....	72
Check of battery charge.....	72
Check of screw tightening	73
Grease the mechanisms.....	74
Safety check	75
Red emergency stop push button.....	75
SQ1 Microswitch.....	76
Safety speed	76
Inclination	76
Protections against overturning	77
Load limiting device.....	78
Antishearing operations	78
Battery inspection and cleaning.....	79
Emergency lowering check.....	79
Engine brushes check	80
Check of brakes on ramp	80
Braking spaces.....	80
Structure check.....	81
Check of wheel reduction gear oil.....	82
Check of hydraulic tubes	82
Replacing hydraulic oil	83
Checking performance	83
Safety speed	83
Steering speed	84
Check register	86

This edition contains the use and maintenance of the self-propelled aerial platforms : IT6390 - IT8290 - IT10090.

The difference between the three described models is in the machine frame and therefore in the height :

IT6390 manufactured with 3 scissors reaches a height of 6,270 m.

IT8290 manufactured with 4 scissors reaches a height of 8,150 m.

IT10090 manufactured with 5 scissors reaches a height of 10,020 m.

The three models have been designed and manufactured to be electrically operated and with operational controls.

The platform manufacturer is :

ITECO S.p.a.
46020 PEGOGNAGA (MN) ITALIA
Via S. Francesco D'Assisi, 8
Tel. +39 0376.554011
Fax +39 0376.559855
E-mail: info@itecolift.it - www.itecolift.it

Foreseen conditions of use

The self-propelled aerial platforms here described can be used to lift persons, materials and equipment accordingly with the foreseen technical data described in the suitable sheet, on solid and strong grounds and after a Qualified Operator has checked that he is working under safety conditions.

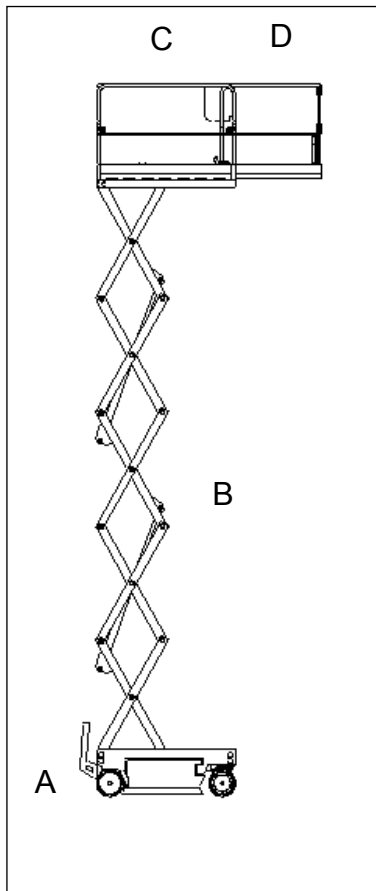

It is equipped with:

- base or truck (A)
- lifting structure or scissors (B)
- support or platform (C)
- platform extension (D)

The possible movements are the following:

- Platform lowering and lifting;
- Backward and forward traction of the machine;
- Steering;
- Manually-operated longitudinal travelling of the mobile platform.

The foreseen operating places for the operator are two, one in platform for the normal operations and one at ground used also under emergency situations.

Using one operator place doesn't allow the other place to come into operation.

The movements are controlled by the platform control workplace.

The lifting and lowering operations of the platform could be also carried out from the ground control panel.

The traction movement could be carried out simultaneously with the steering.

The backward and forward traction of the machine is carried out independently of the height of the platform which could be also entirely lifted.

The platform lowering/lifting and machine traction are carried out independently of the extension of the platform which could be entirely extended.

The machine could be used:

- with temperatures between $-10/+40^{\circ}\text{C}$;

It is possible to face the maximum slope with :

- Machine entirely closed.
- The operator solely on board.
- Selecting the slow speed.
- On even ramp without transversal inclinations.

The machine is equipped with overturning railings to minimise the maximum height , when the machine is completely closed, thus allowing the passage through openings of reduced height.

After-sale service

For interventions, repairs and revisions, address to workshops which have available qualified personnel as well as the suitable equipment. The ITECO Technical After-Sale Assistance is available to give explanations and give assistance with skilled persons.

Spare-part service

A good and lasting working guarantee is assured by only use original spare parts; make reference to the "SPARE PART CATALOGUE". Always state the data described on the identification plate placed on the truck if you need spare parts or assistance.

Structure of the handbook

- General recommendations - safety rules
- Technical features and dimensions of the machine
- Use of the machine
- Maintenance



This instruction handbook must be carefully preserved by the user for the whole machine life, even if the machine is lent, rent or sold.



The figures described in this handbook DON'T exactly reproduce the model described but these are used for a better and easier understanding of the text.

General recommendations - safety rules

The aim of this handbook is to help the operator to well know the platform for an effective use under maximum safety conditions; it is for this reason that it is very important to read and well understand this handbook.

Safety systems

The safety systems applied to the machine are inevitably subject to wear and to go out of tune. Therefore, they must be controlled and kept in perfect efficiency; also, it is not advisable to evaluate their operational and safety conditions only on the basis of their functioning.

The presence of safety systems does not relieve the operator of the responsibility of using the machine in an adequate and conscious way.

Remove, modify or tamper important self-propelled aerial platform instruments is strictly forbidden in order to assure its safety and stability.

In particular as batteries have also a stabilizing function, in case of replacement, check that their weight is not lower than the one indicated in the technical data table of the machine.

Any tampering of the main instruments and safety devices of the aerial self-propelled platform could cause the immediate lapse of the guarantee terms.

Adhesive labels and plates

Possible dangers and prescriptions concerning the machine are described on labels and plates ; therefore it is important that these are well readable and in good conditions.

Operator's requirements

The operator shall:



- Read and well understand all the documentation enclosed to the machine, be properly trained and instructed in the correct use of the machine and know the safety rules and devices.
 - Be of age.
 - Be physically in good conditions and not make use of dope, alcohol or drugs that could affect the attention, the reaction, the sight and the hearing.
 - Make always use of an assistant in areas where the sight is obstructed.
 - Use suitable accident prevention equipment accordingly with the working conditions and the local rules in force.
 - During the working keep all the parts of the body inside the railings and both feet have to be firmly rest on the floor surface
 - Give a great importance to safety and refuse to work if you think you are not working under safe conditions.
 - Always work under highest safe conditions, tidiness and cleaning.
 - Make a daily check before using the machine and also to controls and safety devices and make sure they are in perfect working order.
 - Check the working area is free from persons, animals or obstacles before making any movement of the machine.
 - Check that the ground where the machine has to operate is free from holes, bumps, drops, uneven level, obstructions, debris and coverings which could hide possible potholes or others dangers.
 - Well-know the allowable maximum capacity.
 - Clean from oil and grease the ladder, the floor surface of the platform and the handrails.
 - Once the work has been finished and when the machine remains unattended, switch the machine off and take the key off to avoid that unauthorized persons can use it.
 - Commuting the controls on the platform, always take the key off to avoid an unauthorized use from the operating place on ground while personnel is present on the platform.
-

- The safety manager must hold a spare key enabling to use the operating place on ground as emergency place when the machine is in use. In case of faults, emergency lowering is always possible by manually operating on the electro-hydraulic control unit.
-

Not allowable operations

It is strictly forbidden:



- Use the machine out of closed places.
- Use the machine on slippery, frozen, muddy, uneven ground and with holes, which has a slope higher than the allowed limit; make sure the ground suitably support the maximum load per each tyre.
- Use the machine near free flames or source of heat.
- Use the machine in environments with explosive atmosphere.
- Carry out works near high-voltage transmission lines at a distance lower than 5 meters.
- Modify the machine and use it in a different way from what it has been described in the instruction handbook.
- Modify or remove the safety devices.
- Fasten the machine to adjacent structures.
- Do not lean out of the safety perimetric railings of the platform.
- Use the machine as a crane.
- Use the machine without an adequate environmental lighting to work or to move under safety conditions.
- Load the machine with an higher weight compared to the nominal range.
- Carry more people than indicated.
- Increase the maximum available working height by putting ladders or scaffolds on the platform.



- Place materials on the handrails.
- Run on public roads.
- Move the machine with the opened box.
- Use the machine without making sure the gate to be admitted to the platform is closed.
- Use an horizontal force above 400N.
- Throw some objects and tools from the top to down and vice versa.
- Use the machine if the working area is not free from obstacles which could cause dangerous conditions.
- Use the handrails as admittance means to get on or get down from the platform.
- Get on or get down from the platform when it is in the lifting position.
- Operate or lift the platform when it is placed on the truck loading platform or other vehicle.
- Charge the batteries near sparkles or free flames.
- Lift the platform making sure there are not any obstacles above it.
- Work with a machine operating under bad working conditions.
- Enter in contact with fixed or mobile objects.
- Go up and down the ladder when the back box is not completely closed.

To minimize hazards Follow the here below instructions:

Precautions for the travelling with the lifted platform



- Check the ground is firm and even.
- Do not use the machine on slippery, icy, muddy ground and with holes, which has a slope higher than the allowed limit.
- Check that the ground where the machine has to operate is free from holes, bumps, drops, uneven level, obstructions, debris and coverings which could hide possible potholes or others dangers.
- Comply with the maximum load and the allowable number of persons.
- Distribute the loads and place them if possible in the middle of the platform.
- Make sure the ground resists to the force and load of tyres.
- Avoid the machine knocks against fixed or mobile obstacles.
- Do not use the machine with materials suspended to the handrails or to the scissors lift.
- Give the best attention during movements with mobile travelling platform.
- During movements, lifting and lowering of the platform, check that there are not obstructions around, over and under the machine.
- Carry out the movements only if the working area visibility is complete.

Electric hazards

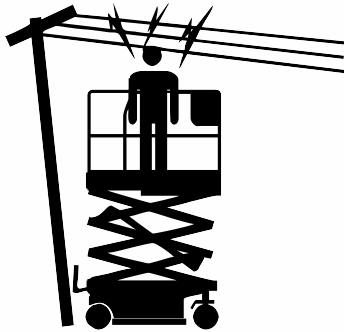

- To assure the earth-leakage of the electrostatic charges, the front partition of the machine, beyond the driving wheels, is equipped with a conductive strip.
Always check the wear of this braid and its contact with the earth.
- As the machine is not electrically insulated, the operator has to pay a particular attention to avoid any contact with probably energized parts.
- As already mentioned in the section “Not allowable operations”, do not carry out works near high-voltage transmission lines at a distance lower than 5 meters.

Explosion or burn hazards

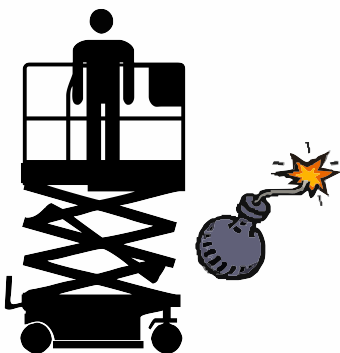

- Do not use the machine near open flames or heat sources.
- Charge batteries in ventilated environment, far from heat sources or explosive fluids.
- Do not use the machine in case of oil leakage.

Description of the machine

Main components

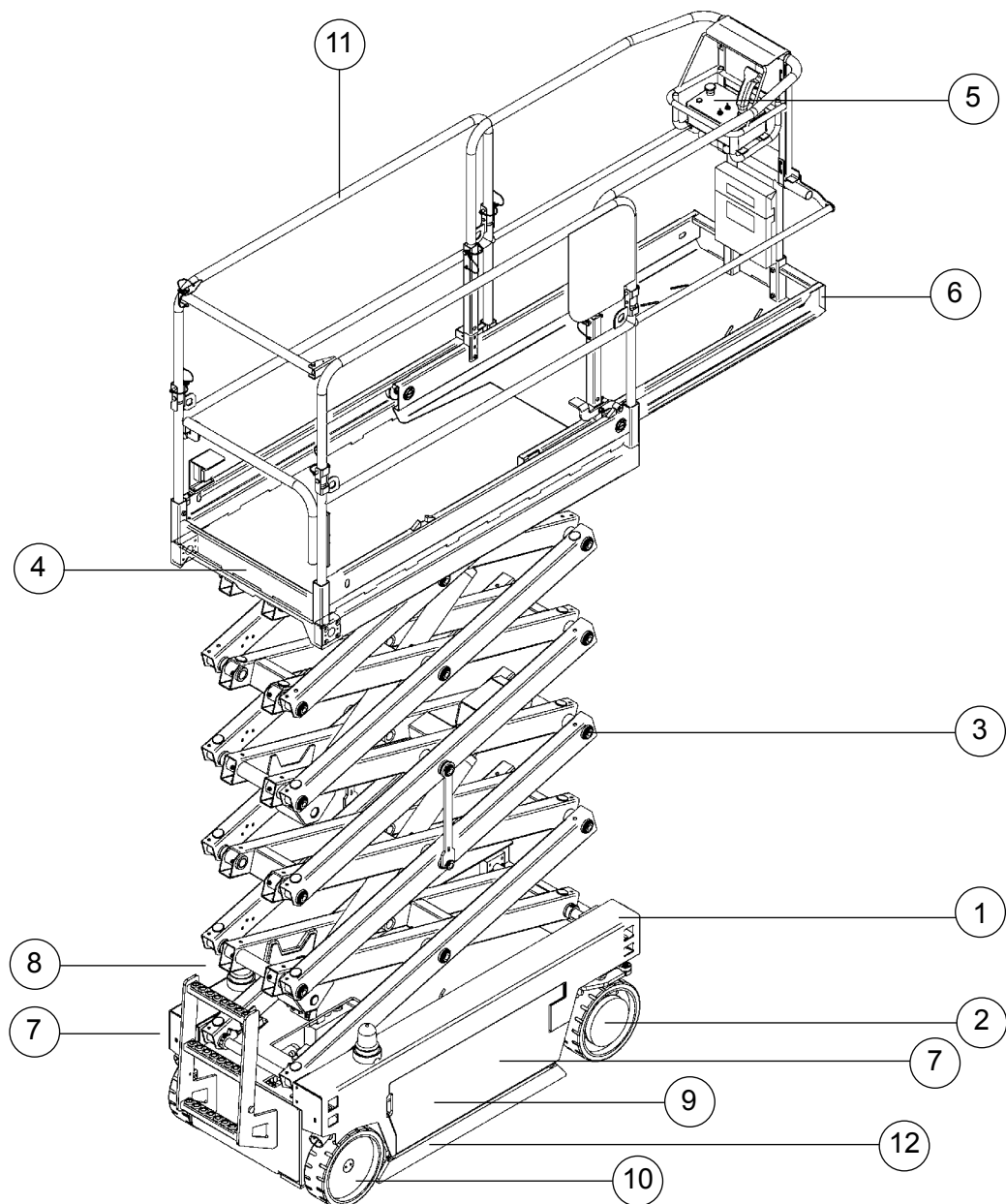



- | | |
|--|--------------------------------------|
| 1 - Truck | 6 - Platform extension |
| 2 - Drive wheels | 7 - Batteries |
| 3 - Lifting structure:
IT6390 3 scissors 1 lifting cylinder
IT8290 4 scissors 1 lifting cylinder
IT10090 5 scissors 2 lifting cylinders | 8 - Ground control panel |
| 4 - Fixed platform | 9 - Electro-hydraulic control unit |
| 5 - Control box | 10 - Idler wheels |
| | 11 - Railings |
| | 12 - Protections against overturning |

Identification

A metallic plate fixed to the truck contains all data necessary to identify the machine

iteco 		PIATTAFORME AEREE SEMOVENTI		CE	
VIA S.FRANCESCO D'ASSISI 8 - 46020 PEGOGNAGA (MN) ITALY - TEL. +39 0376 554011 - www.itecolift.it					
MODELLO	IT6390	MASSA	kg	2065	
MATRICOLA		BATTERIA	V/Ah	24/250	
ANNO DI COSTRUZIONE		PRESSIONE MAX	bar	135	
POTENZA	kw	3,8			
A00031IT					

iteco 		PIATTAFORME AEREE SEMOVENTI		CE	
VIA S.FRANCESCO D'ASSISI 8 - 46020 PEGOGNAGA (MN) ITALY - TEL. +39 0376 554011 - www.itecolift.it					
MODELLO	IT8290	MASSA	kg	2530	
MATRICOLA		BATTERIA	V/Ah	24/250	
ANNO DI COSTRUZIONE		PRESSIONE MAX	bar	175	
POTENZA	kw	3,8			
A00031IT					

iteco 		PIATTAFORME AEREE SEMOVENTI		CE	
VIA S.FRANCESCO D'ASSISI 8 - 46020 PEGOGNAGA (MN) ITALY - TEL. +39 0376 554011 - www.itecolift.it					
MODELLO	IT10090	MASSA	kg	3120	
MATRICOLA		BATTERIA	V/Ah	24/300	
ANNO DI COSTRUZIONE		PRESSIONE MAX	bar	175	
POTENZA	kw	3,8			
A00031IT					

The data refers to the standard model

Description

The here described platform is a machine able to travel, steer, lift and lower the platform.

The traction movement is electrically-operated; the lifting lowering and steering movements are hydraulically-operated.

The truck is outfit of two front steerable drive wheels to travel and steer; the two back wheels are idler.

The traction and steering movements are electrically-operated; the lifting and lowering movements are hydraulically-operated.

To lift and lower the platform a hydraulically-operated cylinder (for IT6390 – IT8290), two cylinders (for IT10090) work on the scissors supporting the platform surrounded by overturning railings and protections.

Traction and lifting operations are controlled by proportional control device respectively operated by two electric motors fitted on front wheels and by an electrical pump.

Steering is operated by an electric pump that supplies a hydraulic cylinder with energy.

The energy of each machine is supplied by electric batteries that feed the motors and the electric pumps.

The control and power instruments are installed in the three boxes and in the middle of the truck:

Right box

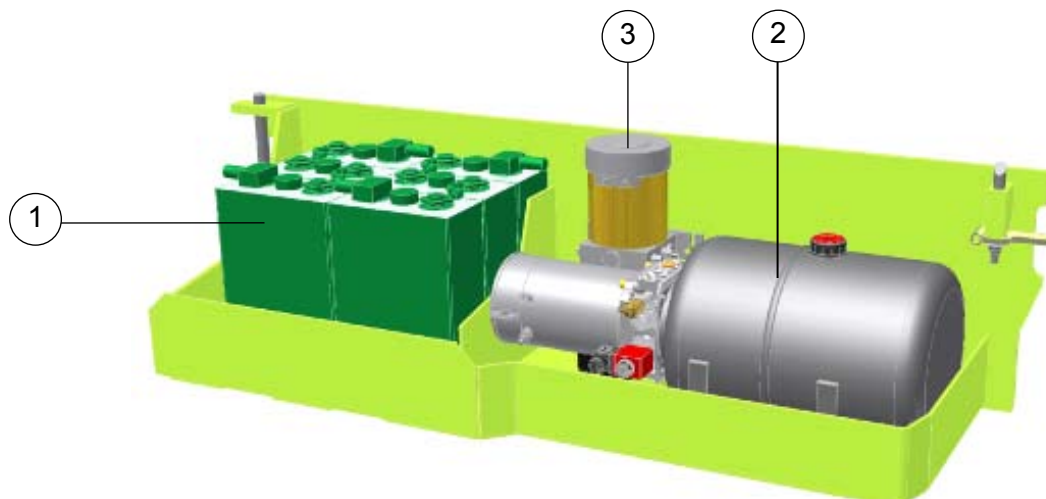

- 1 Fuses
- 2 Lifting electric pump
- 3 Steering electric pump

Left box

- 1 Batteries
- 2 Ground control panel
- 3 Load control system
- 4 Fuses

- 5 Battery cut-out
- 6 Remote-control switches
- 7 Mosfet electric motor check
- 8 Power fuse

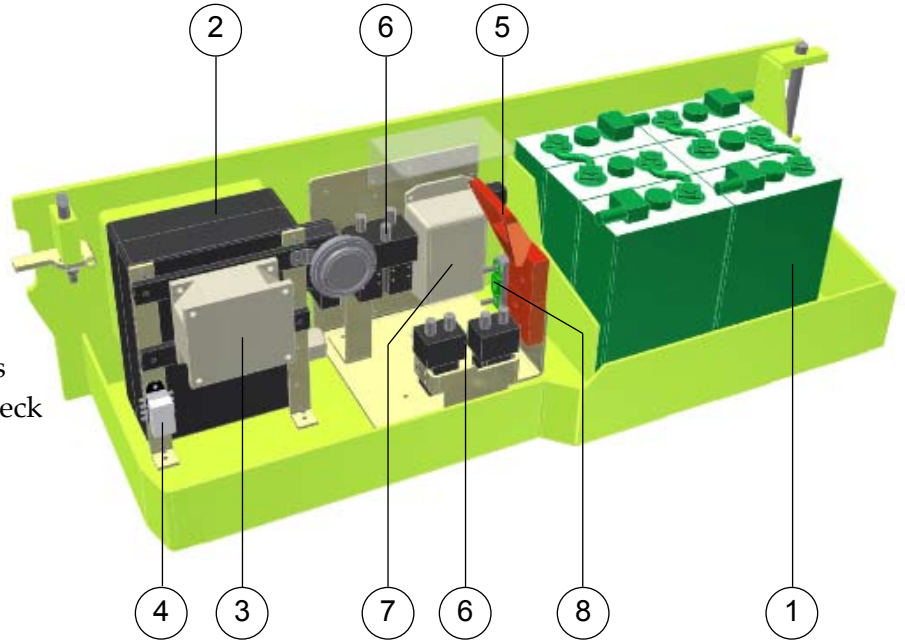

Back box

- 1 Battery charger
- 2 Kit 220V
- 3 Manual pump

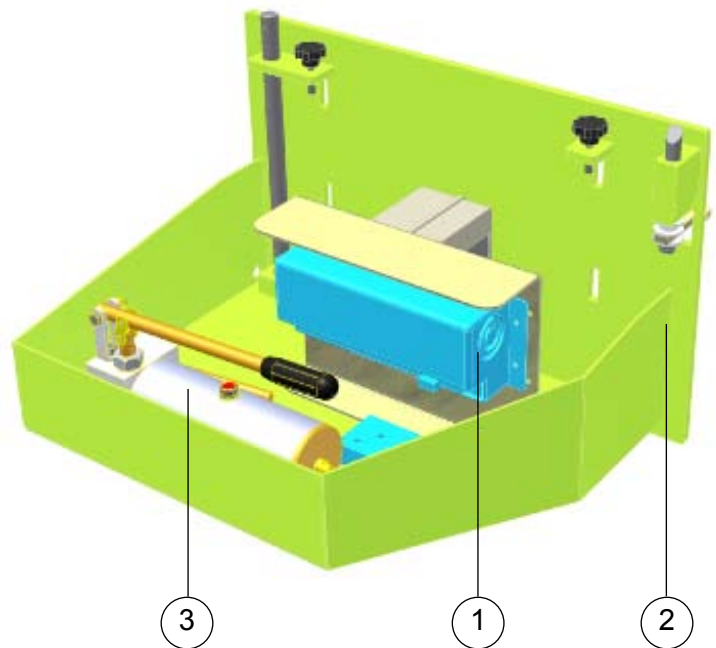

Truck centre

- 1** Inclinometer

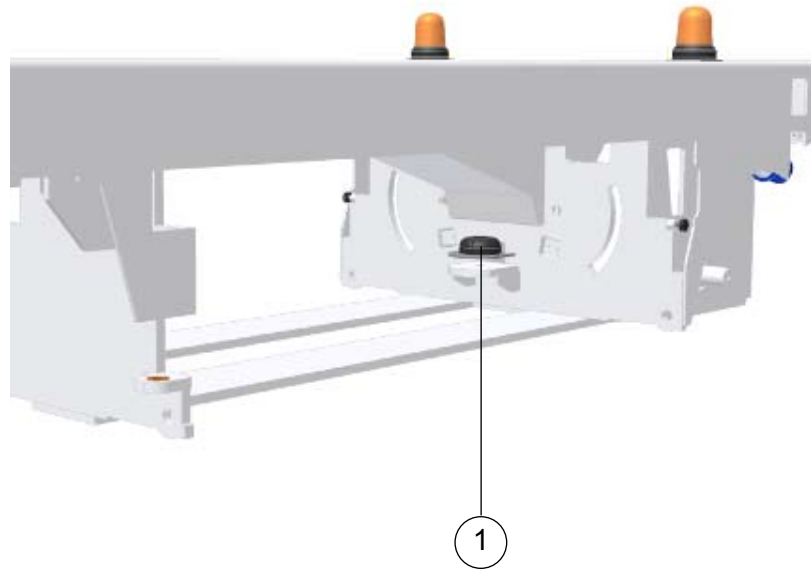

Standard equipment

The machine is equipped with the following:

- Front electric drive with proportional controls
- Parking brakes with electric disengagement.
- 90° steering
- Manually-operated platform extension m. 1.40
- Horn
- Manual emergency lowering device
- Cylinder holding valve
- Audible motion alarm
- Inclinator with motion locking device
- Mechanical wheel drive release for emergency towing
- Battery cut-out plug
- Non-marking tyres 410x130
- Electrical antishearing protections
- Battery control system with low-voltage cut-out protection
- Hour-meter
- Overload sensor
- Overturning railings
- Protections against overturning
- EC marking
- 220V cable with plug, outlet and cut-out box
- Rotating beacons

Optional

- 110V cable with plug, outlet and cut-out box
 - Battery charger kit 110 V
-

Technical features

IDENTIFICATION	UNIT OF MEASUREMENT	IT6390	IT8290	IT10090
Number of scissors	/	3	4	5
Capacity (including 3 persons)	kg	450	350	300
Lifting time (unloaded)	s	31	63	60
Lowering time (loaded)	s	28	35	33
Drive electric motors	V/kW	24 / 3		
Lifting hydraulic control unit	V/kW	24 / 3		
Steering hydraulic control unit	V/kW	24 / 0,8		
Drive battery	V/Ah	24 / 250		24 / 300
Battery weight	kg	4 x 45		4 x 53
Battery charger	V/A	24 / 30		24 / 35
Max. hydraulic pressure	bar	135	175	175
Oil tank capacity	l	16		
Drive speed	km/h	4		
Safety drive speed	km/h	0,7		
Max. slope	%	25		
Max. allowed side force	N	400		
Inside turning radius	m	0		
Outside turning radius	m	2,23		
Wheels dimensions	mm	410 x 130		
Wheels type	/	cushion		
Load on front wheels	daN	1500	1600	1700
Load on rear wheels	daN	1000	1200	1750
Max side / longitudinal inclination	degrees	2 / 3	2 / 3	1,5 / 3
Total weight	kg	2065	2530	3120
Level of acoustic pressure weighed at operator's place	dB (A)	< 70 dB (A)		
Machine for indoors use				

Vibrations

As regards vibrations, according to the measurements carried out in the most unfavourable conditions of use, it has been established that:

- the root-mean-square value weighted in the frequency of the upper components acceleration is lower than 2,5 m/sec²;
- the root-mean-square value weighted in the frequency of the body acceleration is lower than 0,5 m/sec².

Overall dimensions

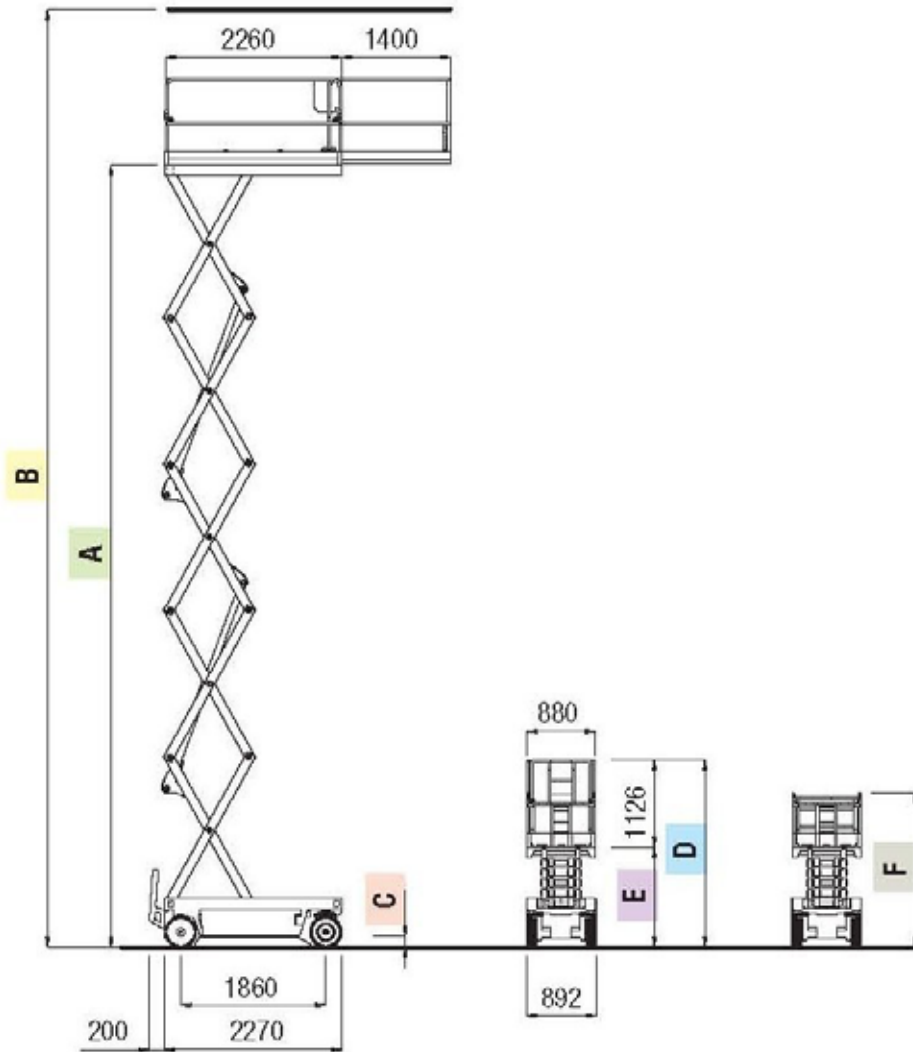

	A	B	C (Pot-hole up / down)	D	E	F
IT 6390	6270	8270	120/24	2150	1020	1720
IT 8290	8150	10150		2280	1150	1850
IT 10090	10020	12020		2410	1280	1980

Plates and adhesive labels

An annexe enclosed herewith describes the position and codes of rating plates and adhesive labels to be positioned on the machine.

Operating principles

The proportional control machine is controlled by an electronic system that according to the joystick movements on the platform control panel supplies more or less energy to the electric motors and to the electric pumps.

The energy required for the machine running is supplied by 24V batteries, which can be recharged thanks to a battery charging device.

Here below the main features of the electric, hydraulic and electronic circuits are described.

Electric circuit

Two electric motors installed in the front steerable wheels supply the energy required for the traction action.

Pressing the red emergency stop push button in the ground control panel and in the platform control box, any function of the machine is disconnected, except for safety indicators (pilot lights and audible alarm).

Only by turning the key of the ground control panel in the OFF position, machine functions are completely disconnected.

Hydraulic circuit

The electric pump supplies the hydraulic energy required for the steering movement, operated by a solenoid valve.

In case of failure a manually operated action will allow the scissors lowering.

A further electric pump supplies the hydraulic energy required for the steering movement, operated by a hydraulic cylinder.

Electronic circuit

The electronic equipment of the machine is composed of two cards with microprocessors placed in the ground control panel and in the platform control box and are connected by the Can-bus messaging protocol.

The electronic system surveys some failures through a self-diagnosis. The display placed on the ground control panel displays the error codes.

The battery discharging level is electronically-operated.

Safety systems

Microswitches

Some microswitches are positioned on the machine with safety functions.

SQ1 Microswitch

The SQ1 microswitch is enabled through the platform lifting movement:

- Enables the flatness indicator which locks the machine movements if this last exceeds the maximum slope, except for the lowering operation.
- Inserts the drive reduced speed.

SQ1 is formed by a proximity sensor system and it is composed of:

- A rectangular-shaped magnetic unit
- A rectangular-shaped sensor with contacts.

SQ1 condition not activated

With the platform rest the sensor and the magnetic unit are near.

SQ1 condition activated

With platform lifted when the sensor and the magnetic unit are separated for more than 3 cm.

SQ5 Microswitch

The SQ5 microswitch, placed on the left back part of the base truck is enabled through the platform lifting movement to a height of 1.45 m (IT6390) - 1.65 m (IT8290) - 2.30 m (IT10090) from the floor surface.

- Prevent traction and steering movements in case the protections against overturning are not lowered (combined with SQ6A-SQ6B microswitches).
-

SQ3 Microswitch

The SQ3 microswitch (pos. 1) placed in the right rear part of the truck, is enabled by the platform lifting.

- It stops the lifting movement to the maximum height before the cylinder mechanical limit switch.

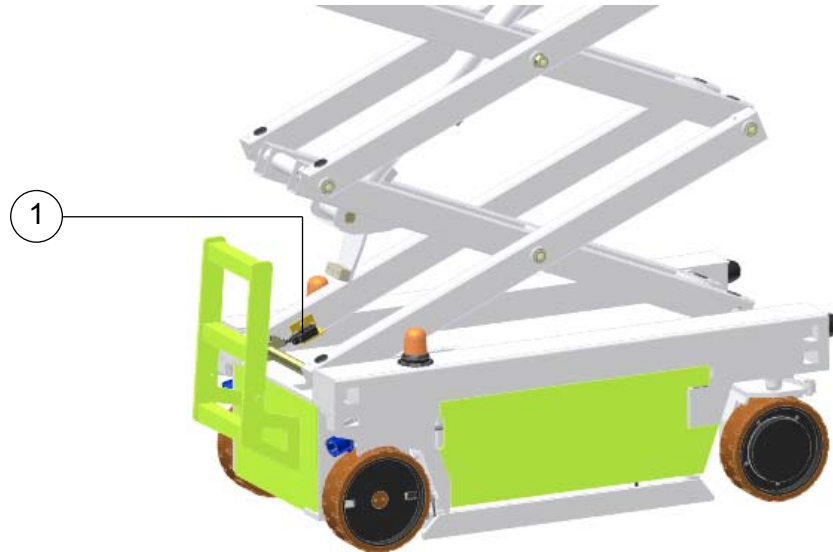

SQ6A - SQ6B Microswitches

The microswitches SQ6A - SQ6B (pos.1,2), being located in the inside part of the back connection of the truck, stop the traction and steering movements, when the platform has lifted above the operating height of SQ5, if the protections against overturning are not fully lowered.

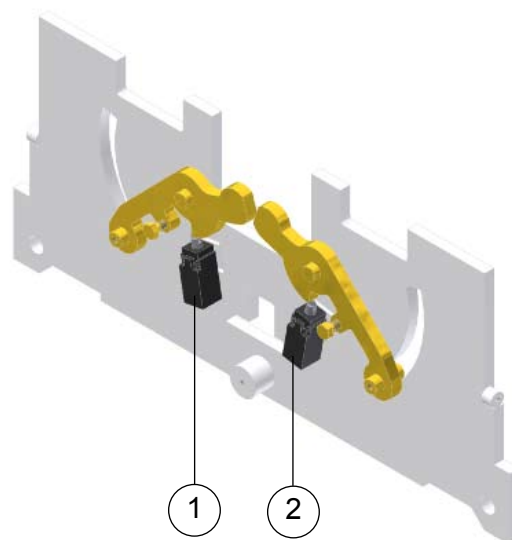

Antishearing operations

An electronic control unit stops the lowering for 5-6 seconds, when the distance between the arm and frame ends is 60 mm approx. (anti-shearing safety).

When the lowering is locked, it is necessary:

- bring the joystick in standstill position,
- wait for 5-6 seconds checking that the persons being side the platform do not risk to be trapped or crushed between scissors,
- give again the lowering command.

Battery connection plug

The battery connection plug is placed in the left box.

This safety device disconnects the power and control circuits of batteries and the battery charger solely remains connected.



Make sure the batteries are disconnected before carrying out the electric equipment maintenance.



Emergency stop push button

The red emergency stop push button is placed both on the ground control panel and in the platform control panel.

Pressing the push button both from the ground control panel and from the platform control panel, any movement and command of the machine are disconnected, except for safety indicators (pilot lights and audible alarm). In order to restore normal functions, pull push button upwards.

Only by turning the key of the ground control panel in the OFF position, the machine is turned off and its safety functions are disconnected.

Flatness indicator

The microprocessor flatness indicator is a digital device, placed in the middle of the truck, able to control the maximum slope at which the machine can work.

Should it exceeds the allowable maximum slope, could cause:

- Under the SQ1 operating height, the inclination warning light on the platform control panel blinks. If you want to reach a level above SQ1, restore machine conditions in which warning light is off.
- All machine movements stop when SQ1 operating height is exceeded, apart from platform lowering which is signalled by the switching on of the inclination and danger warning light on platform control panel (See platform control panel - position 16 and 15 and "Emergencies" section) as well as by a sound alarm. For enabling movements again, the platform must be completely lowered and the machine must be put to a stable condition again.



The flatness indicator must not be modified for any reason

Load limiting device

The load limiting device consists of:

- An electronic control unit positioned in the left box
- An angular sensor (positioned under the platform)
- An analogue pressure sensor (positioned on lifting cylinder/s chamber directly)

Overloads, if any, are checked by the above-mentioned device both with the machine at a standstill position and during platform lifting. An overload pilot light is on both in the ground control panel and in the platform control panel, and an audible alarm is activated in the presence of a load between the nominal one and a value up to 120% of the latter: all machine movements are stopped.

To enable the movements again, it is necessary to remove the overload.

Safety belt connection

The machine is provided with suitable attachment points for the safety belts (A) as indicated in the following picture:

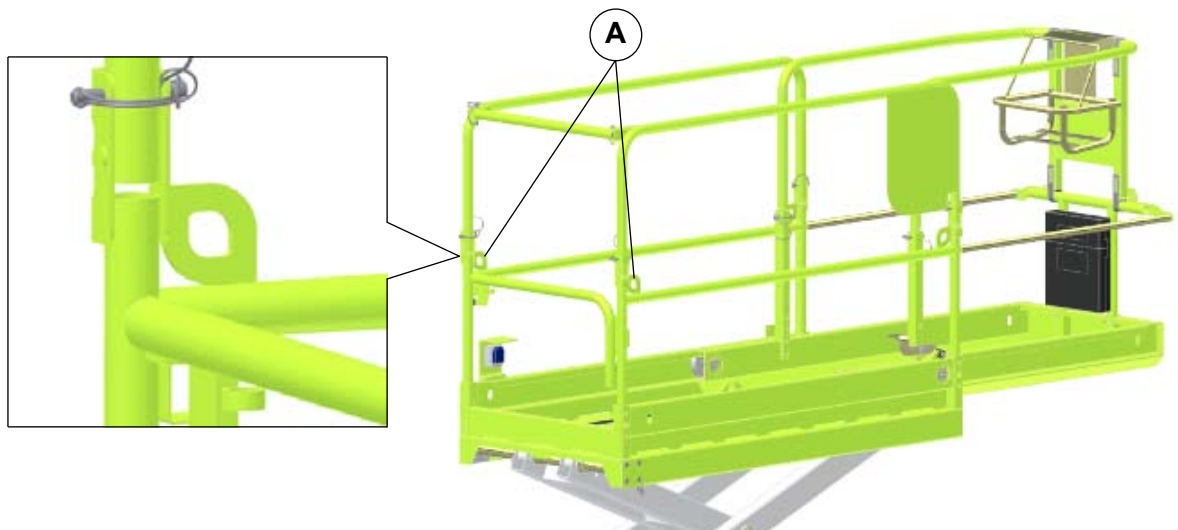

Use of the machine

Before carry out any operation it is necessary read and well-understand this handbook along with the instructions described on plates and adhesive labels.

Checking before use

Before setting at work the machine and carrying out any operation, the machine itself has to be subjected to a visual and operating check described here below.

During the setting at work it is also necessary carry out the safety device checking.

Visual checking

Make sure that the following failures are NOT occurred:

- Oil leakage from pipes and others hydraulic components.
- Cut or disconnected electric wires.
- Missing or unloosed nut in the wheels.
- Worn or cuts in the wheels.
- Damages, deformations, loosen or missing screws and bolts, cracked welding on chassis, wheel supports, steering systems, lifting systems, platforms and railings.

Check

- the soil where the platform should operate is solid and able to support the maximum load per each wheel.
 - the operating handbook is on board and plates and adhesive labels well visible
 - the ladder, handrail and the platform are free from grease and oil traces.
 - the working area is free, without holes and uneven grounds.
-

Operating check

Once the visual inspection has been finished it is also necessary to carry out an operating check.

- Check the hydraulic oil level.
- Check the electrolyte level in the batteries.
- Check that all the foreseen plates and adhesive labels have been suitably positioned and are legible.

From ground

- Make sure the batteries are well charged.
- Press STOP push button and check that no operation could be enabled both from ground and from platform. Put push-button to ON again.
- Lift and lower the platform more times and check that no obstacle could occur during these operations.
- Make sure the protections against overturning are lowered during the platform lifting operation.
- Make sure the lowering horn and the electric anti-shearing device well work during the platform lowering.
- Carry out operations described in the “Emergency lowering” section and check that everything works well.
- Lift the platform till the protections against overturning are completely lowered, push each protection inwards the truck and check they keep still.

From platform

- Press STOP push button and check that no operation could be enabled both from ground and from platform. Put push-button to ON again.
 - Lift and lower the platform more times and check that no obstacle could occur during these operations.
 - Make sure the lowering horn and the electric anti-shearing device well work during the platform lowering.
 - Drive forward and back and check the operation is correct and audible alarm well works.
 - Check that during traction only steering movement is enabled.
 - Right and left steer and check the operation is correct.
-

- Press horn and check if it works correctly.
 - During traction release the joystick to check the brakes work correctly: the machine should stop in a narrow space.
 - Lift the platform above the working height of SQ1 and try the traction forward and back, making sure the drive speed is made under safety conditions.
-

Controls and Action

This section shows the control panels and operations that can be carried out from ground and from platform.

Note

As previously explained in the "Safety systems" section, the machine is provided with safety devices in order to avoid injuries when using the machine beyond its power.

The safety devices stop the machine or neutralize its movements; the limited knowledge of the machine features and operation could suppose the Operator that there is a defect, while it means that the safety devices work correctly.

Hereafter we sum up the conditions under which the safety devices stop the movements of the machine.

- | | |
|--------------------------|--|
| Traction | <ul style="list-style-type: none"> • The safety speed is automatically activated, when the platform exceeds the working height of micro SQ1. • It is locked if the load exceeds the established limits. • It is stopped above the working height of micro SQ1 if: <ul style="list-style-type: none"> - the maximum slope is exceeded • It is stopped above the working height of micro SQ5 if: <ul style="list-style-type: none"> - the sliding blocks against overturning are not entirely lowered. |
| Steering | <ul style="list-style-type: none"> • It is locked if the load exceeds the established limits. • It is stopped above the working height of micro SQ1 if: <ul style="list-style-type: none"> - the maximum slope is exceeded • It is stopped above the working height of micro SQ5 if: <ul style="list-style-type: none"> - the sliding blocks against overturning are not entirely lowered. |
| Platform lifting | <ul style="list-style-type: none"> • It is locked if the load exceeds the established limits. • It is stopped above the working height of micro SQ1 if: <ul style="list-style-type: none"> - the maximum slope is exceeded. |
| Platform lowering | <ul style="list-style-type: none"> • It is locked if the load exceeds the established limits. • It is locked for 5-6 sec. when the distance between arm and frame ends is 60 mm. approx. (anti-shearing safety device). |

Control panels

The aerial lifting platform is equipped with 2 control panels: ground control panel and platform control panel.

All movements are controlled by platform control panel; ground control panel is an emergency control position.

Ground control panel

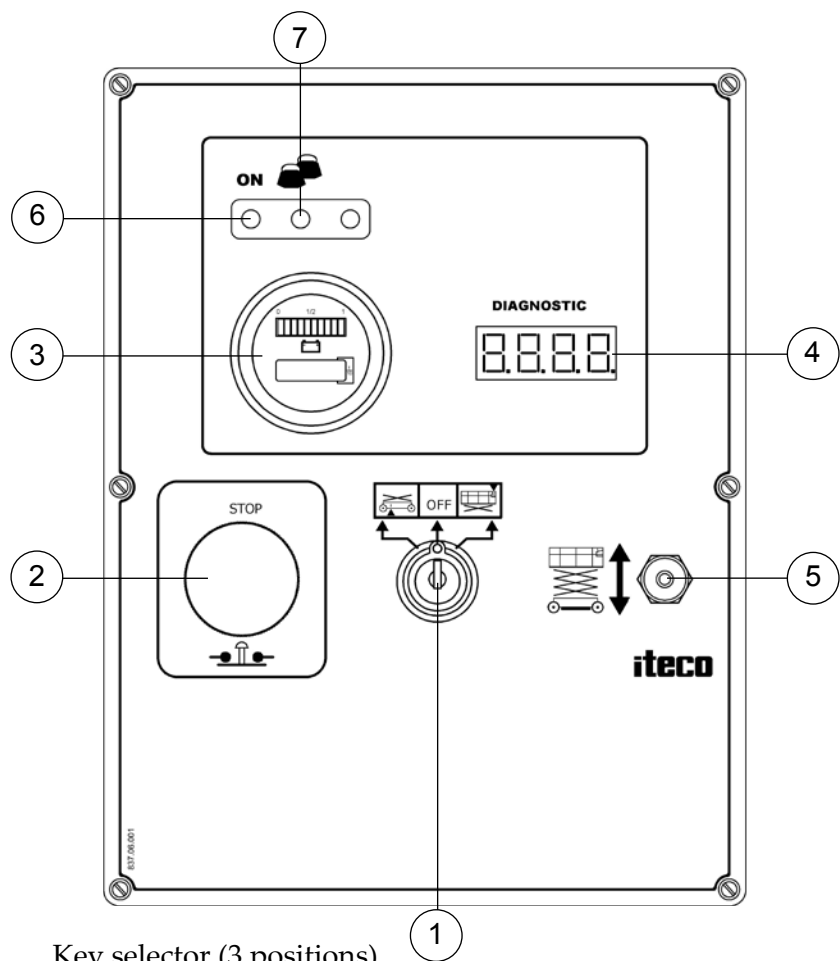

- 1 Key selector (3 positions)
- 2 Red emergency stop push button
- 3 Hour counter and battery check display
- 4 Diagnostic display
- 5 Platform lifting/lowering selector
- 6 Pilot light machine ON
- 7 Overload pilot light

Platform control panel

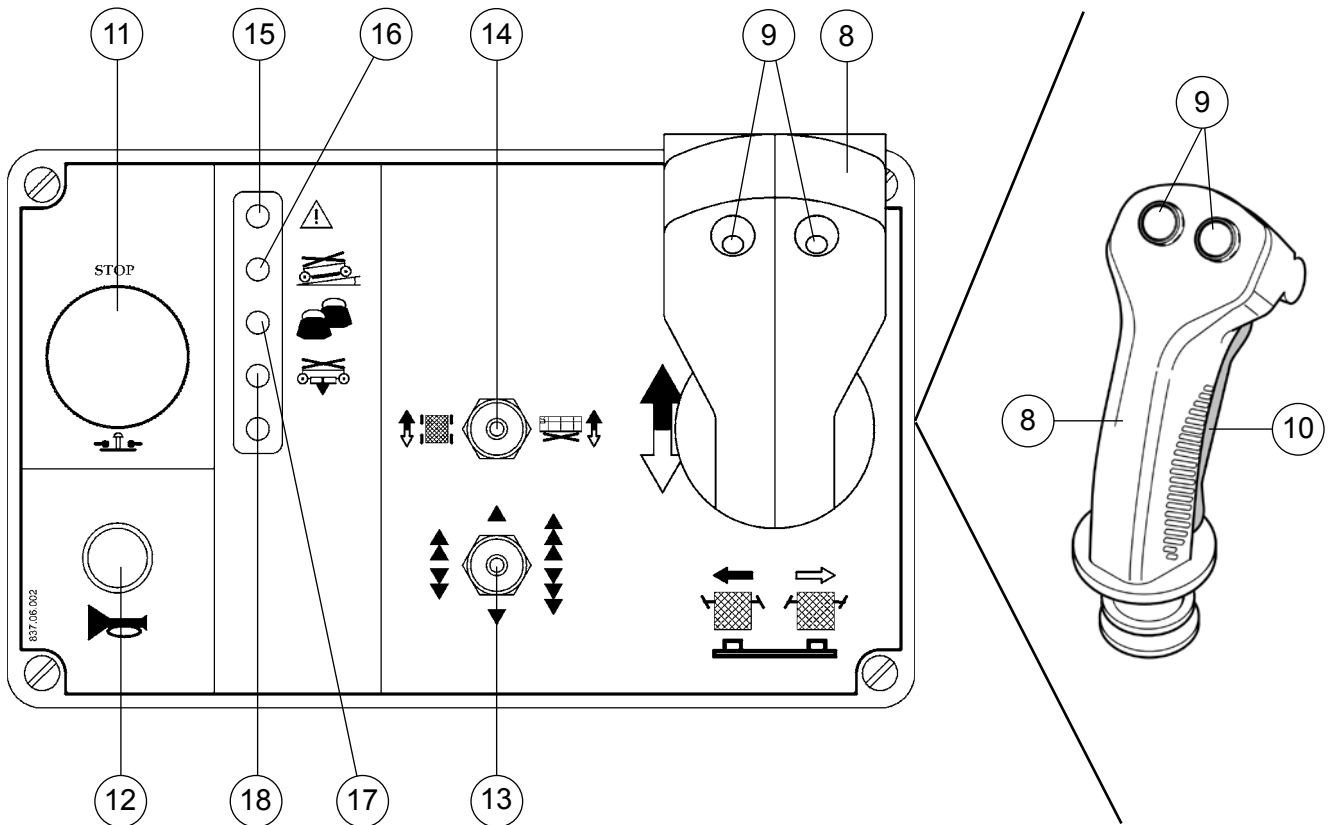

- 8** Traction and lifting control joystick
- 9** Steering control switches
- 10** Push button man-present
- 11** Red emergency stop push button
- 12** Horn button
- 13** Drive speed selector
- 14** Traction or lifting function selector
- 15** General diagnostic pilot light
- 16** Pilot light unstable machine
- 17** Overload pilot light
- 18** Protections against overturning pilot light

Operations from ground

Controls enabling the operator to switch the machine on and operates with the ground control panel are the following:

Starting and enabling platform controls

- Platform lifting/lowering
- Other functions hereinafter described are:
- Emergency stop

Other functions hereinafter described are:

- Overload pilot light
- Battery charge indicator
- Hour-meter
- Diagnostic display



Make sure that the emergency stop red push button on ground or platform control panel is not pressed.

Starting and enabling ground controls

- Each time the machine is started up, the signal lights and audible alarms are switched on to verify their correct running (pilot lights and buzzer). Before using the machine, wait they are switched off.
- Insert key in selector 1 and turn **left**, keeping this position, in order to put **ground controls** into operation (in this position it is not possible to extract the key); the pilot light 6 goes on. If the key is released, it returns automatically in the middle position (OFF), and the machine is stopped.

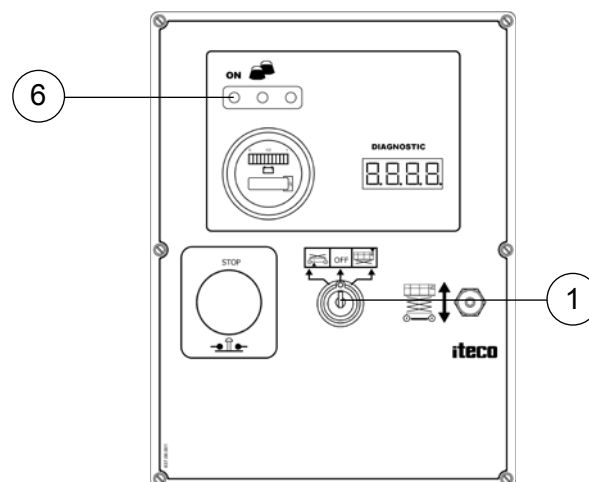

Platform lifting/lowering

- Turn left the key in selector 1 by maintaining the position and move selector 5 **upwards** in order to lift platform or **downwards** to lower platform.

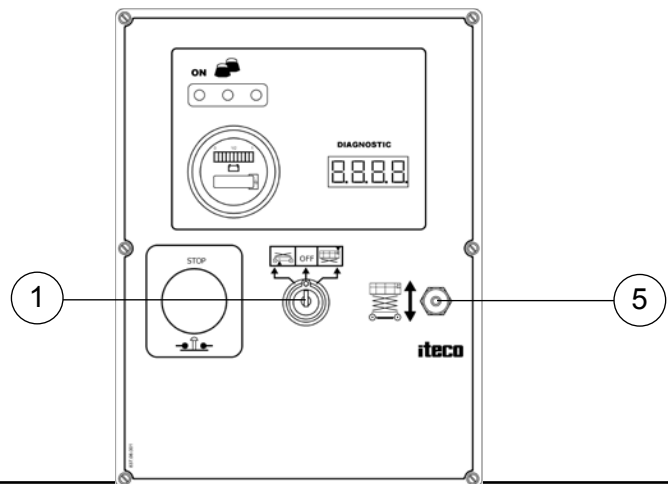

Before lifting or lowering platform make sure that no obstacles are present on or under it.

Starting and enabling platform controls

- Insert key in selector 1 and turn **right**, in order to put **platform controls** into operation ; the pilot light 6 goes on. The key remains in fixed position and it is possible to extract it.

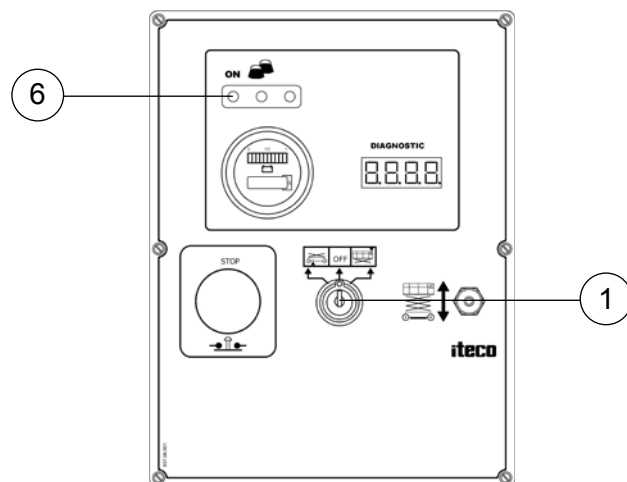

Emergency stop

- Press push button 2.

In this way all movements and commands of the machine are interrupted both from ground and from platform, except for safety indicators (pilot lights and audible alarm).

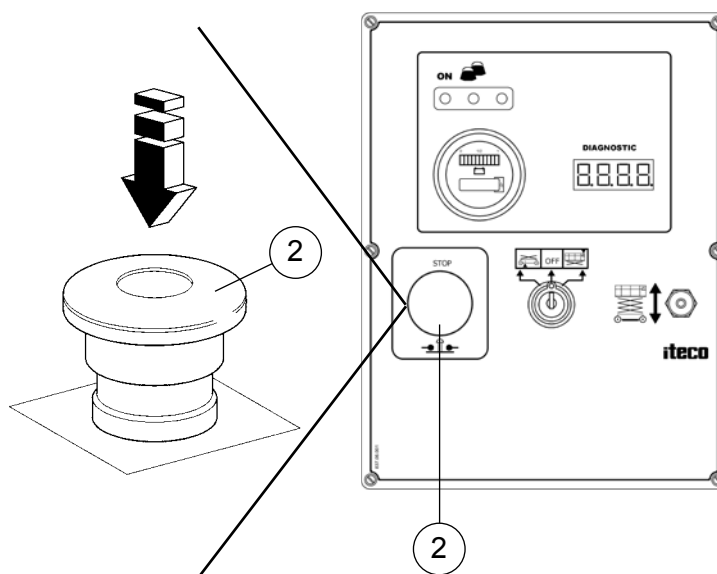

In order to restore the normal functions pull push button 2 upwards.

Overload pilot light

See "Emergencies" section.

Battery charge indicator - Hour counter

The device provided in the ground control panel shows the battery charge state and the working hours.

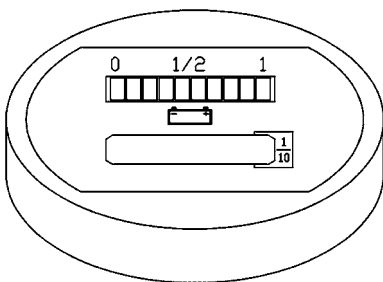

The battery charge state can be read in the upper part of the device.

The discharge is showed by means of luminous bars: 2 reds, 3 oranges, 5 greens.

When the battery is correctly charged, the green bar in the right extremity turns on.

During the discharge phase, the bars turn on in sequence from right to left, one after another.

When battery is discharged for 70%, the first red bar blinks.

When battery reaches a discharge of 80%, the two red bars blink alternately; in this condition the platform lifting is blocked.

For the battery recharge see section "Battery recharge".

The bottom part of the display shows the working hours (machine actuated).

When battery is connected, the total stored hours are displayed.

When hourglass blinks, the counter is counting the working hours.

Diagnostic

In case of problems or malfunctions the display reports an error code used by the After-sale Service for troubleshooting.

Operations from platform

From the platform operating place the operator can carry out following principle functions:

- Traction
- Steering
- Platform lifting/lowering
- Emergency stop
- Platform extension
- Railing overturning

Pilot lights are described in the “Emergencies” section.

In order to work with controls on platform it is necessary to turn right the key in the selector of ground control panel.



Make sure that the load respects the limits and is well distributed.

Make sure that the gate and the protection bar for the access to platform are perfectly closed.

Make sure that the emergency stop red push button on ground or platform control panel is not pressed.

Always check the state of pilot lights ; in case they go on, please, read section “Emergencies”.

All movements from platform described in the following pages depend on the correct position of the control box (refer to “Main components”). A plate placed on the front railing signals the correct position of control box.

If the control box is moved (A), use the coloured direction indicators on control box support (B) and on the front side of the platform (C) in order to control the movement direction of the machine.

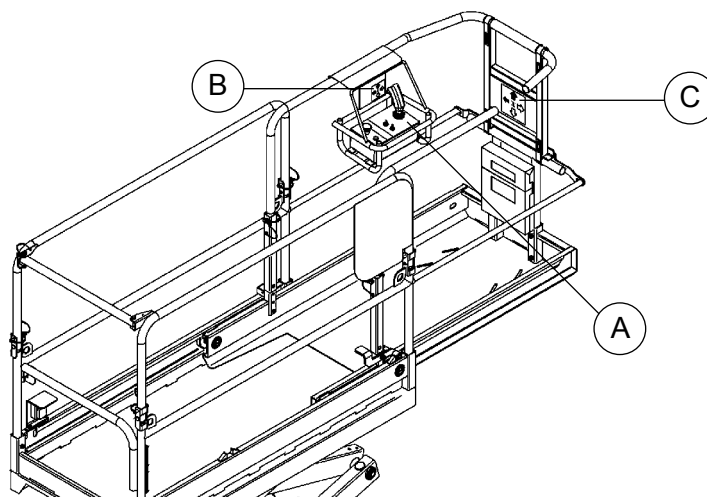

Traction



During movement, do not move selector 14 from traction to lifting position and vice versa. In this case the machine stops. Release the joystick 8 and give the command to restore the movement.

- With machine **in stop position**, move selector **14** left to select the traction movement.
- Move selector **13** on the desired speed:
Fast: selector to the **right**
Slow: selector to the **left**
Safe: selector in the **middle**
- Hold joystick **8**.
- Press push button **10** "Man present" and keep it pressed.
- Bring the joystick forward or backward depending on the desired running direction and keep it in that position during the whole movement. It is also possible move as first think the joystick 8 and after press pushbutton 10 to begin the manoeuvring.

The move speed is adjusted according to the inclination given to joystick 8 and to the position of the speed selection push button 13.

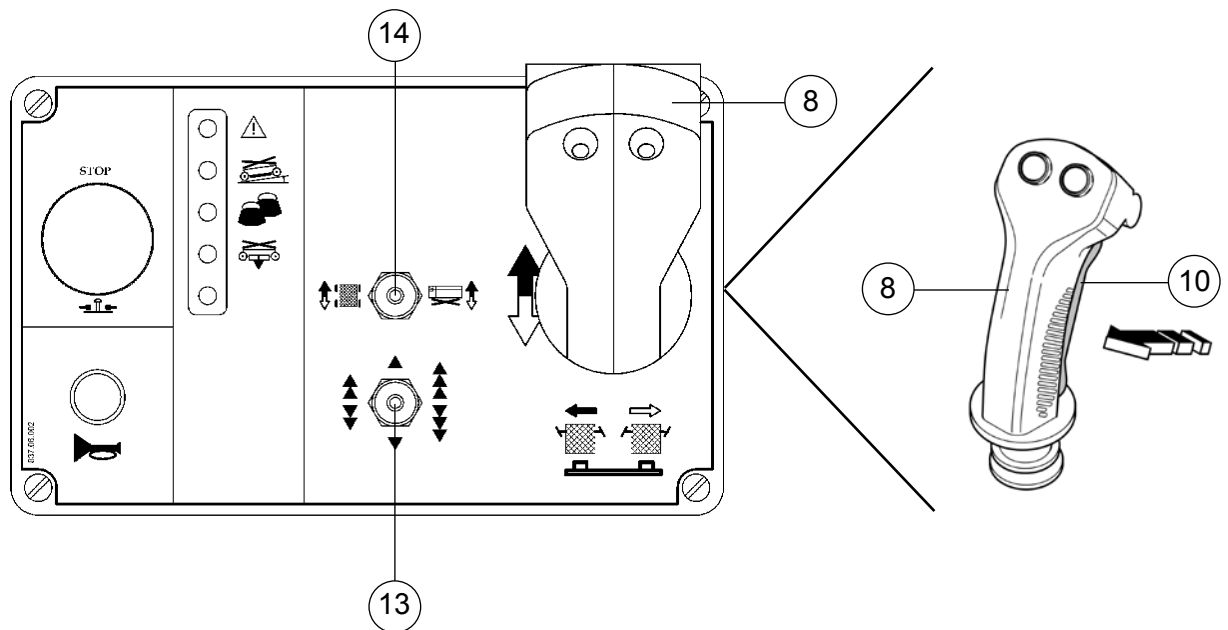

The traction is signalled by an audible alarm.



Before moving the machine, make sure that the way is free from obstacles, holes, bumps, unevenness, obstructions or debris and that no coverings are there, which can hide holes or other dangers.



Always check the state of pilot lights ; in case they go on, please, read section "Emergencies".



Do not move the machine, when the platform is extended, without having checked that there are not any obstacles even in area where there is a poor visibility.

While performing traction with lifted platform over the working height of micro SQ1 the safety speed is automatically started.

Traction stopping

Slow: bring gradually joystick 8 back into the starting position, keeping pressed the push button 10 "Man present". The braking electronic control device guarantees a soft stopping.

Fast: release switch 10 "Man present". The braking electronic control device assures a quick stopping.

Traction controlled from ground

To pass through openings having limited height, it is possible to drive the machine from ground using the platform control panel (push button panel on board), making sure that:

- the railings are overturned (1);
- the operator remains at a minimum distance of 1 m from the machine;
- the selected speed is the slower one;
- the machine is entirely lowered (closed) (2);
- make use of the direction arrows being on the control box support (3) and on the upper side frames (4), in order to locate in one way the direction of steering and drive.

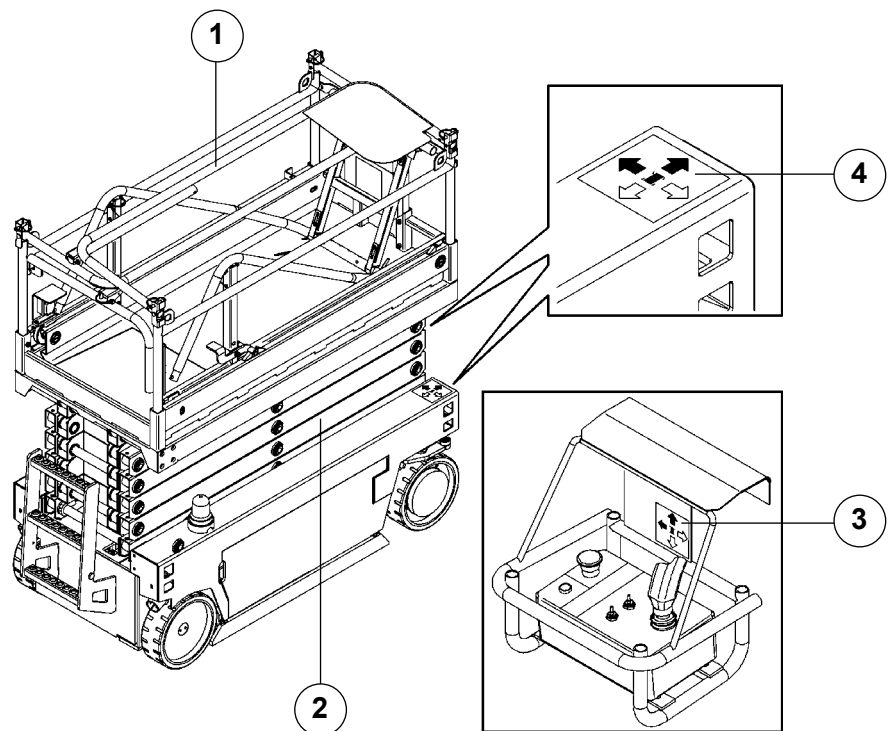

Steering

- During traction press switches 9 of joystick 8 to the right or left in order to steer in the desired direction.

In order to turn the wheels when the machine is stationary, bring joystick 8 into the central position and use switches 9 as described before.

The “man present” push button 10 should be always pressed.

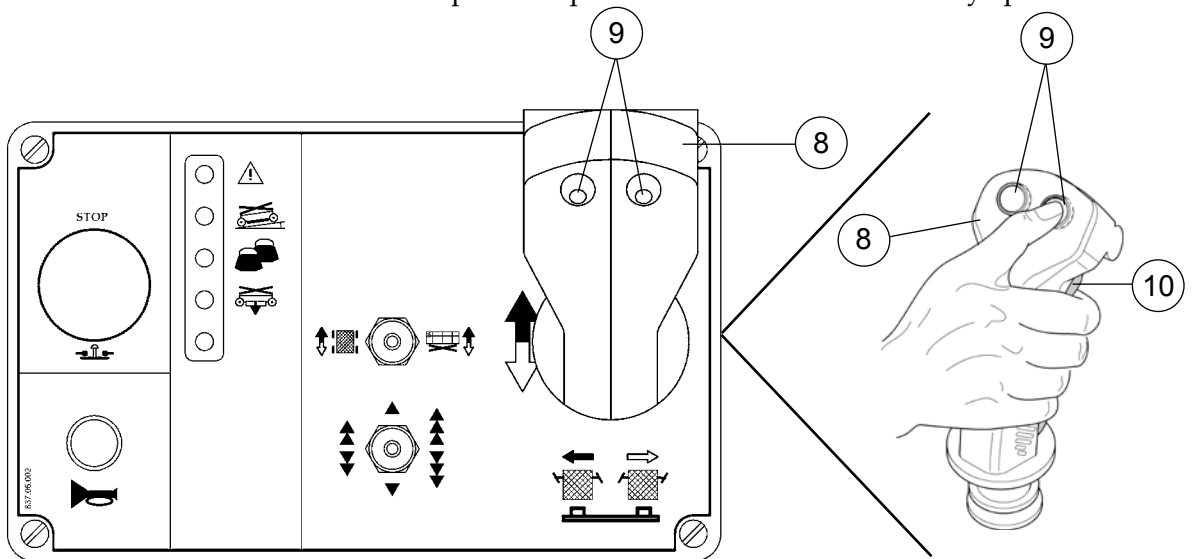

Before moving the machine, make sure that the way is free from obstacles, holes, bumps, unevenness, obstructions or debris and that no coverings are there, which can hide holes or other dangers.



Always check the state of pilot lights ; in case they go on, please, read section “Emergencies”

Platform lifting/lowering



During movement, do not move selector 14 from traction to lifting position and vice versa. In this case the machine stops. Release the joystick 8 and give the command to restore the movement.

With machine **in stop position**, move selector 14 right.

- Hold joystick 8.
- Press push button 10 "Man present" and keep it pressed.
- Bring the joystick forward to lift the platform or backward to lower it.

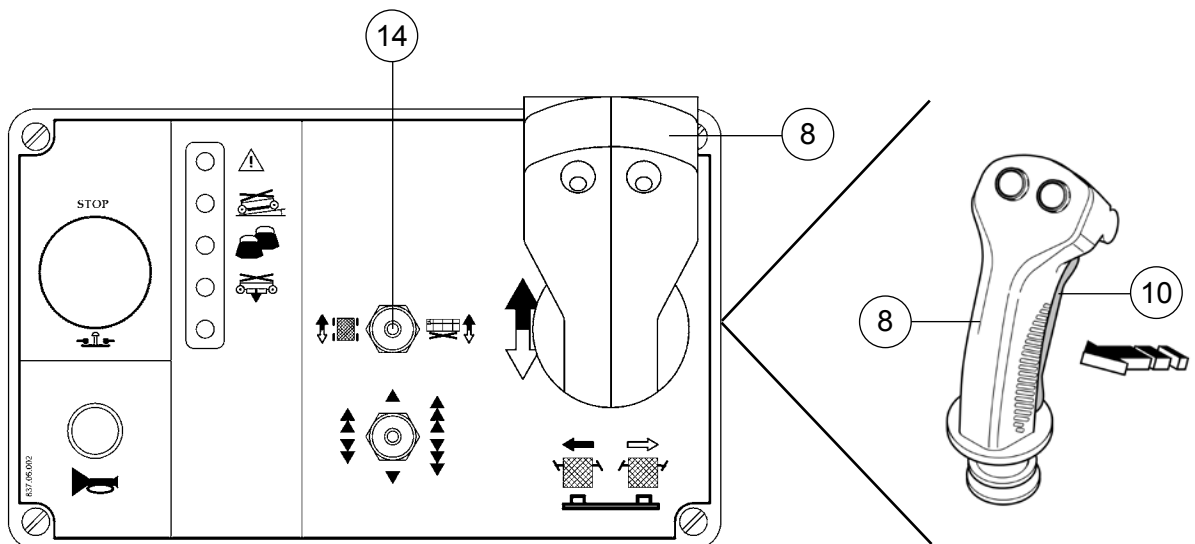

The lifting speed is adjusted according to the inclination given by the joystick 8.



Before lifting or lowering platform make sure that no obstacles are present on or under it.



Always check the state of pilot lights ; in case they go on, please, read section "Emergencies"

Lifting stopping

Slow: bring gradually joystick 8 back into the starting position, keeping pressed the push button 10 "Man present". The electronic control device guarantees a soft stopping.

Fast: release switch 10 "Man present". The electronic control device assures a quick stopping.

Lowering stopping device

Bring joystick 8 back to starting position or release the "Man present" push button 10: the stopping happens immediately.

Emergency stop

Press the red emergency stop push button 11:

- In any emergency situation.

By pressing the mushroom-shaped push button all movements and commands of the machine are interrupted both from ground and from platform, except for the safety indicators (pilot lights and audible alarm).

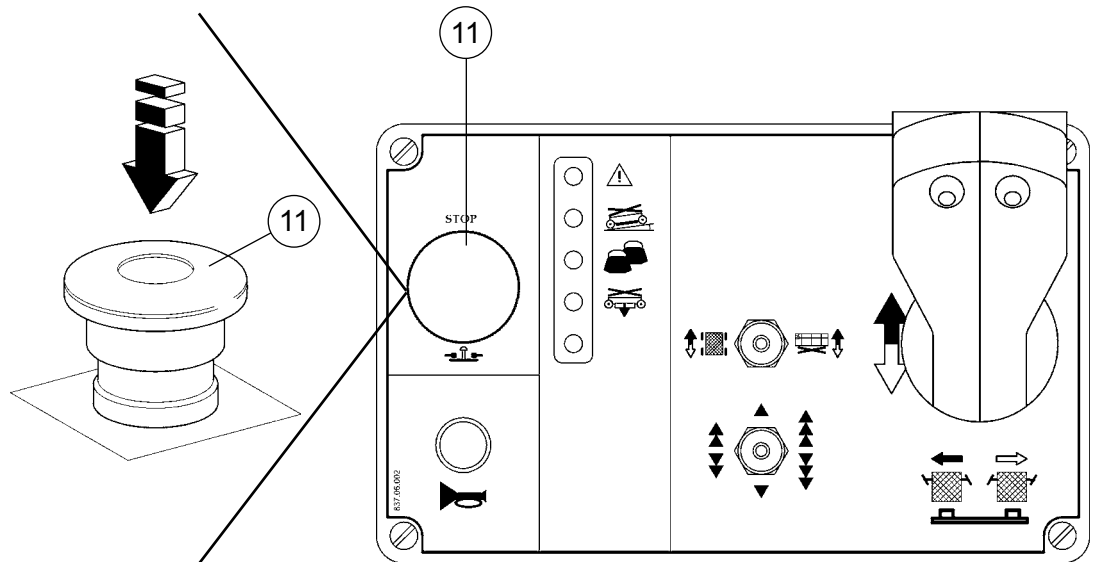

In order to restore the normal functions pull push button 11 upwards.

Platform extension

The platform is equipped with a manually-operated extension.

To extend the platform it is necessary:

- To be positioned on the fixed platform.
- Press with right foot on the pedal (part. A) placed on the platform and grip the mobile railing.

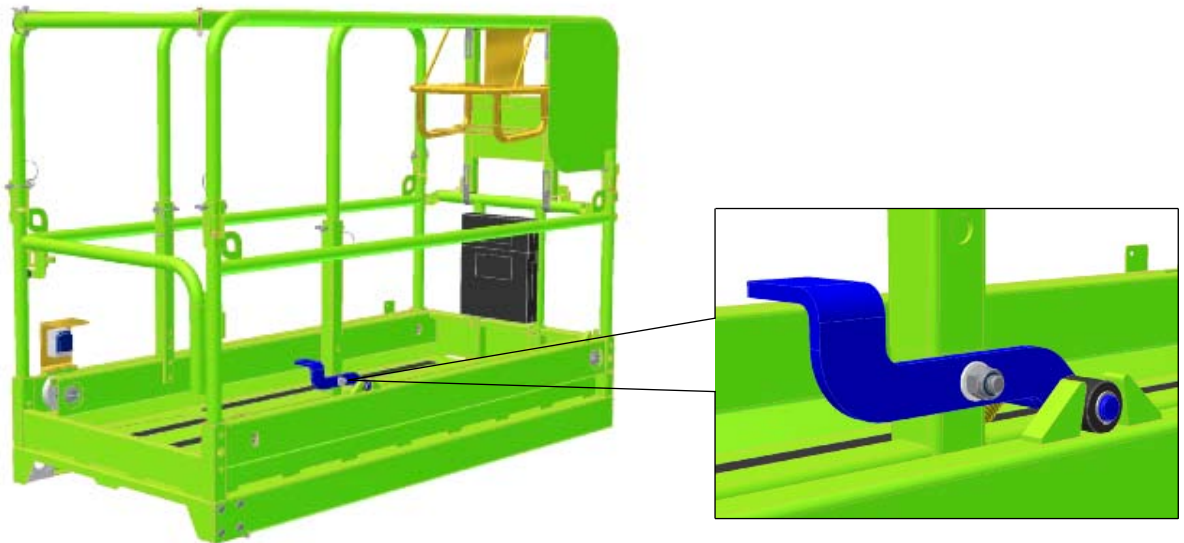

- Push the platform until the pedal pivot arrives above the lock (part. B).
- Release the pedal making sure the suitable lock stops the pin (part. B).

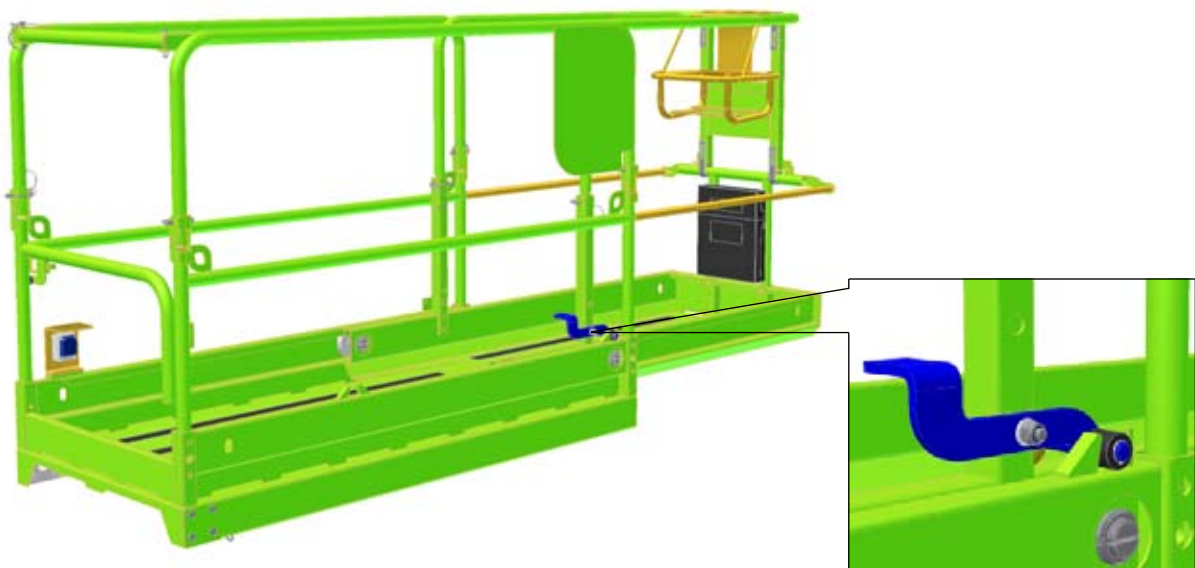

Railing overturning

It is suggested for a better practicability to overturn the railings with extended platform.

- Position the control box with relevant support on the platform extension.
- Take the spring plungers away from the 2 extension masts and lift the mobile railing.

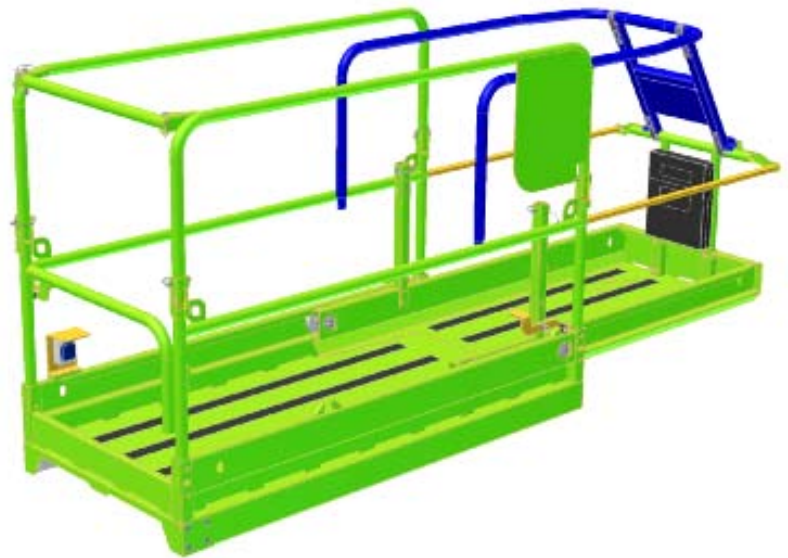

- Lay the railing on the platform overturning the front part.

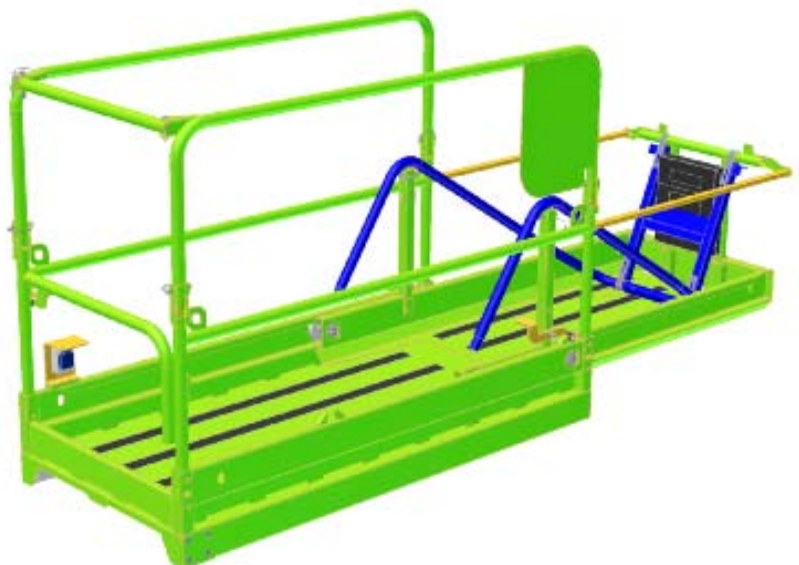

- Retract the platform.
- Bend the platform access protection bar as shown in the above figure and extract the spring plungers.

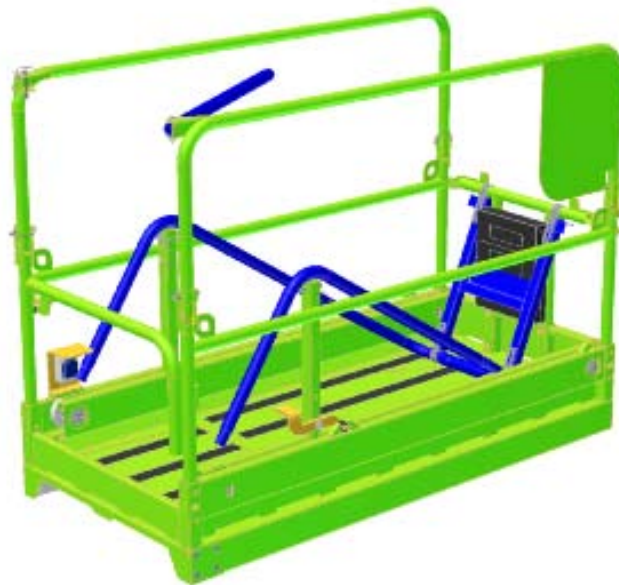

- Take the spring plungers away from hinged points and overturn the side protections.

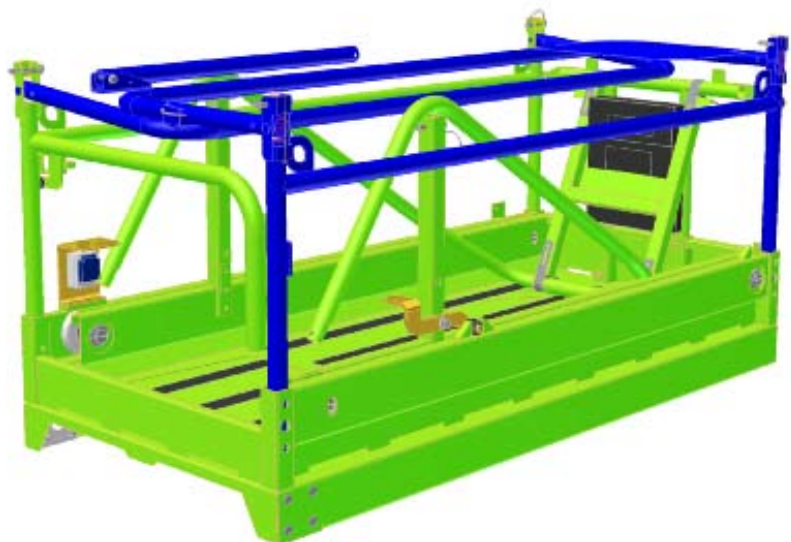

Do not use the machine with overturned railings remaining on board of the machine.

Machine stopping

It is required to stop the machine every time it is left unattended to avoid any undesired use.

- Press STOP switch on platform control panel.
 - On ground panel, bring key selector back into the central position: pilot light 6 “machine ON” goes out.
 - Remove the key and keep it in a guarded place.
-

Emergencies

Pilot light 7 in the ground control panel and pilot lights 15-16-17-18 of platform control panel signal, if ON, emergency situations, with the following partial or total stopping of the machine movements.

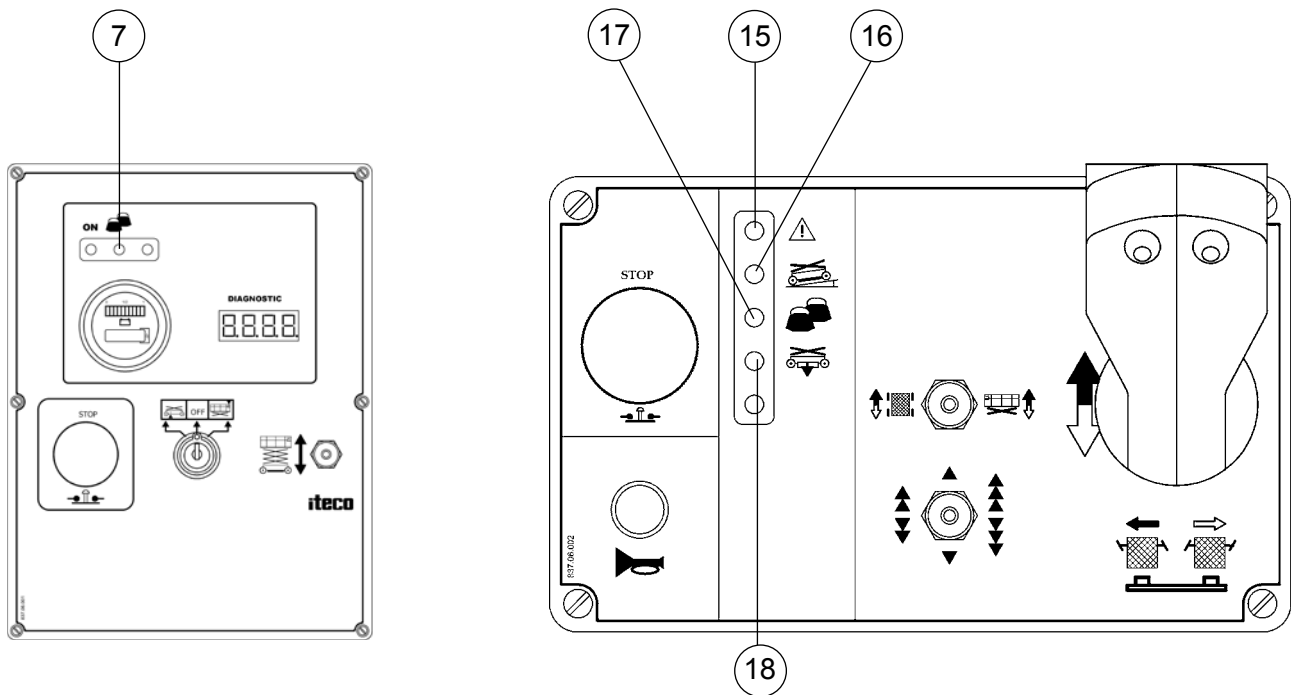

Overload

PILOT LIGHT 7 and 17

A charge limiting device comes into operation in case of overload on the platform: **all the movements are stopped.**

- The total block of all the movements is signalled by:
 - pilot light 7 on ground control panel going on.
 - pilot light 17 on platform control panel going on.
 - an audible alarm.

- In order to restore movements it is necessary:
 - to remove the excessive load

PILOT LIGHT 16

Machine unstable

When the truck is inclined above accepted limits the pilot light 16 is activated:

When the scissor is closed (the platform is at a **lower** height than the working height of SQ1), pilot light 16 flashes : **if it is necessary to lift the platform , it is necessary to bring the machine back into the stability conditions.**

When the scissor is opened (the platform is at an **higher** height than the working height of SQ1) the pilot light 16 flashes and an acoustic alarm is activate, **traction, steering and lifting movements are blocked.**

In order to restore movements it is necessary:

- to completely lower platform and bring the machine back into the stability conditions.



Make sure that no obstacles are present under the platform before lowering it.

PILOT LIGHT 18

Protections against overturning

The protections against overturning reduce the clear height of the machine and increase its stability.

They are lowered when the platform lifts and they are closed when the platform is entirely lowered.

If an obstacle does not allow the protections to lower, **the traction and steering movements are stopped.**

- The movement stopping is displayed by:
 - the lighting-up of pilot light 18 on the control panel.
 - an audible alarm.
- In order to restore movements it is necessary:
 - to lower entirely the platform and remove the obstacle.



Pay attention when the protections are moved in order to avoid crushing.

Should an obstacle doesn't allow to sliding blocks to re-enter, a spring compresses itself to finish the lowering without damage the mechanism.



Do not remove the obstacle when the spring is compressed as this operation is very dangerous, but proceed as follows:

- Lift the platform to release the spring.
- Remove the obstacle.

PILOT LIGHT 15

General diagnostic

This pilot light goes on in order to signal a malfunction in the control system.

Diagnostic display

In case of malfunctions the diagnostic display of the ground control panel shows an error code used by the Technical After-sale Service for troubleshooting.

Emergency lowering

If the machine stops in the lifted position due to a failure, it is possible lower the platform operating on the emergency pump placed on the rear box:

- Press the lever (1) and set it towards the pump body .

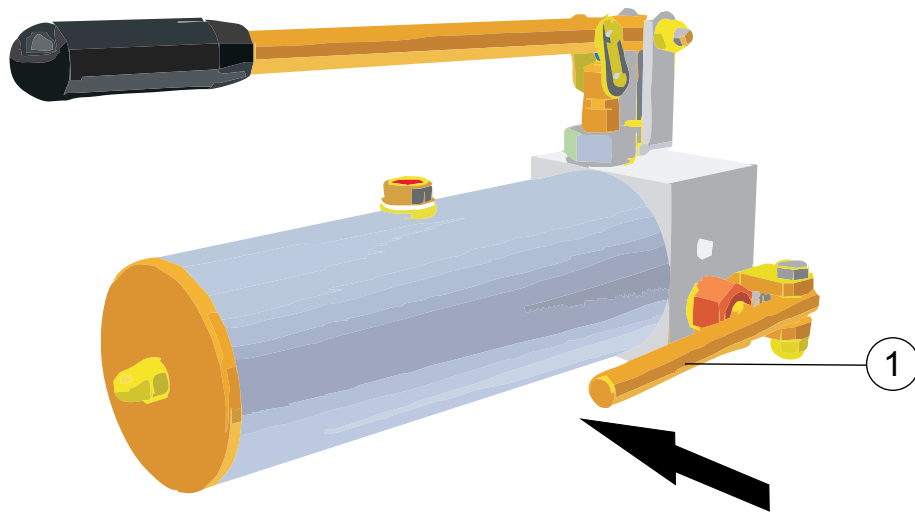

- Operate on the pumping device (2) until platform lowers completely.

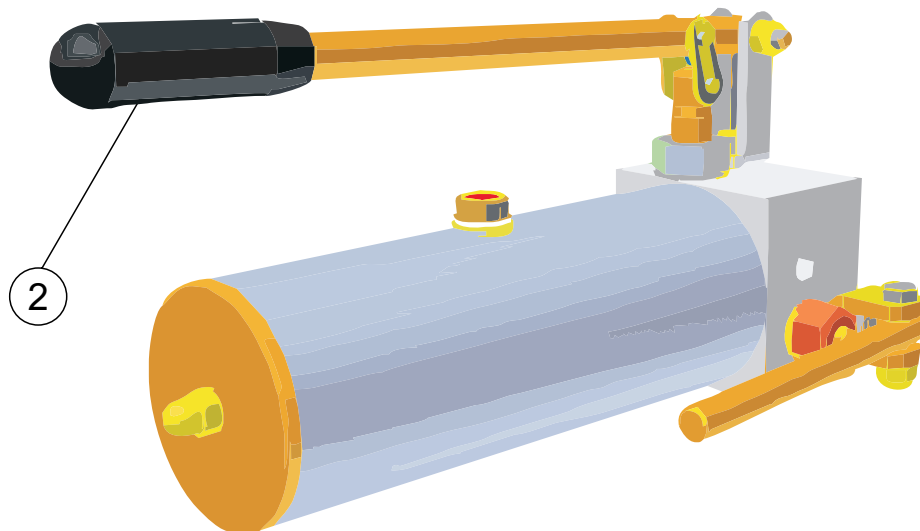

Before carrying out the emergency lowering make sure that no obstacles are under the platform.

This page has purposely been left blank.

Battery recharge

Batteries are the energy source of the machine. In order to use their capacities in the best way without the risk of a premature decay, always carry out the recharge after every use, independently of what the charge indicator signals.



If the recharge is not carried out immediately, a permanent damage might occur to the batteries.



Leaving even only one night the batteries not charged may result in a permanent damage.

The batteries have to be charged with the special battery charger (1) placed in the back box.

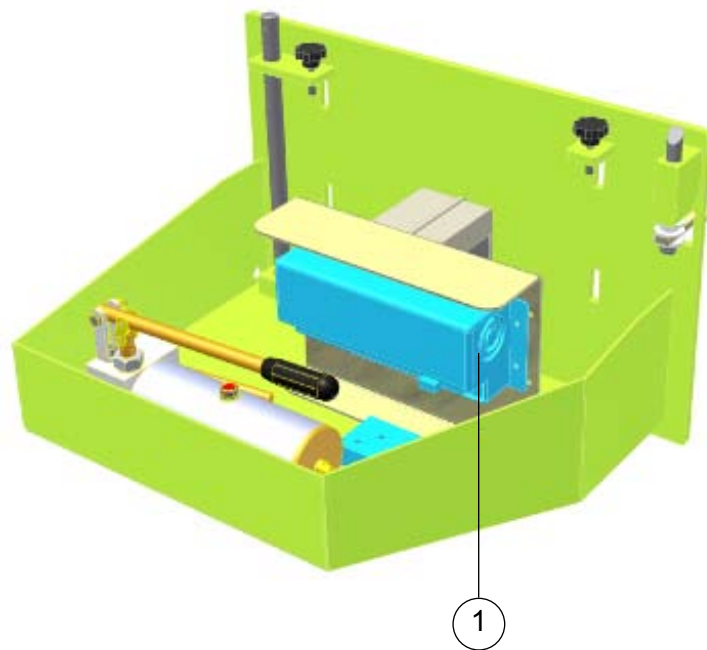

Features

- Battery charger: 24V - 30A
- Power supply: 220V single-phase - 50Hz
- Voltage: 24V
- Charge time: about 12 hours
- Operating temperature: from -20°C to +50°C
- Protection against output short circuit
- Protection against polarity reversal (fuse)
- Weight: 1.5 Kg
- Connection to the net: standard 3 poles 230V outlet

Before the charge

Before starting the battery charge it is necessary to check the electrolyte level and, if necessary, fill up till all elements are completely covered.

- Open the boxes.
- Open the electrolyte filling caps.
- Check the level and if necessary fill up with distilled water.
- Close the caps and wipe away the liquid that might have come out.



The sulphuric acid contained in the solution could cause serious injuries; if it is unintentionally poured, wash immediately the objects or the surfaces with abundant water.

If the acid comes into contact with the skin, wash immediately with abundant water and consult a doctor.

It is recommended to always wear gloves and protective glasses during the maintenance operations of batteries.

Charge start



The recharge is to be carried out in a suitable room, well ventilated and separate from the working room, because batteries generates inflammable gases, which can cause explosions if they come into contact with flames or sparks.



The recharge is to be carried out with open boxes.

By connecting a mains cable to the left back outlet (2), the battery charger is automatically started after a few seconds.

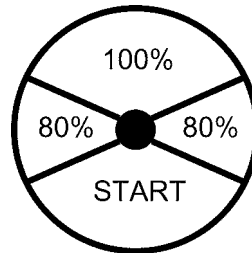

When the battery charger is operating the machine is completely blocked

The led indicator shows the battery charge level through a luminous LED:

The RED LED shows that battery is in the starting phase of the charge.

The YELLOW LED shows that battery has reached 80% of the charge.

The GREEN LED shows that battery has reached 100% of the charge.

One or more flashing leds show that an alarm situation occurred:

Condition	Type of alarm	Description (Action)
flashing GREEN	Timeout	Phase 1 longer than the maximum allowed values. (Verify battery capacity).
flashing RED-YELLOW	Battery current	Exit current out of control. (Control logic fault)
flashing RED-GREEN	Battery Voltage	Exit voltage out of control. (Control logic fault)
flashing RED-YELLOW-GREEN	Thermal	Overtemperature of semiconductors (Verify ventilator operation).

Charge end

When the green led goes on, disconnect battery charger from outlet.

Battery disposal

Run-down lead batteries can not be dumped with ordinary solid waste; being composed of noxious materials, they must be collected, disposed of and/or recycled under the legislation prevailing in each state.

Lifting and transportation

Make sure that:

- The scissor is completely close.
- The machine is off.
- The platform is not extended.
- The means utilized for lifting can support the machine mass equal to: 2065 kg for IT6390 - 2530 kg for IT8290 - 3120 kg for IT10090



Lifting

Lifting may be carried out with a fork truck or a crane. The loading areas are indicated through special adhesive labels.

Use a lifting beam for lifting with a crane. The four coupling points on the machine are indicated through special adhesive labels.



Transportation

During its transport, fasten the machine to the vehicle platform by means of bands passing through the points of attachment indicated for the lifting.



It is forbidden to operate the machine in transportation conditions (placed on the vehicle platform).

Storage

In case of long storage periods, shelter the machine in a dry and ventilated setting, with completely loaded batteries. Reload batteries every 2 months regularly



Before using the machine after a storage period exceeding 30 days, carry out the inspections described in the Maintenance summary table, item "After long periods of inactivity".

Emergency towing

It is not advisable to tow the machine unless an emergency, such as a malfunctioning or a complete breakdown, occurs; nevertheless, the towing procedure is described hereunder:

In case the machine must be towed, make sure that:

- The scissor is completely close.
- The machine is off.

Complete the following operations:

- Connect the machine to the rigid towing bar.
- Unscrew the central cap of the driving wheels.
- Completely remove the central pinion using tweezers and keep it in a clean and sheltered place.
- Rescrew the cap and carry out towing.



In this configuration the machine is not braked; do not exceed 4 Km/h

- Once towing has been completed, remove the central cap, reposition the pinion till its complete engaging and rescrew the cap.
- Check oil level in the reduction gear and, if necessary, fill up.

Disposal and scrapping

The machine consists mainly of steel, aluminium, plastic, synthetic gum and copper.

Special attention must be paid to disposing of electric batteries (D.M. 633/72 art.8) and of the hydraulic oil contained in the tank and in the hydraulic circuit (DPR 691/82).

The main components of the machine are listed hereunder:

- | | | |
|-----------------|--------------------------|-------------|
| • Cast iron | • Polymar | • Polyester |
| • Steel | • Teflon | • Copper |
| • Polycarbonate | • Embossed polystyrene B | • Ertalyte |

220V Line

To supply current in platform it is necessary to connect a mains cable to the right back plug (pos. 3).

A socket foreseen in the platform supplies current to electric instruments.

A cut-out box switch (pos. 1) and a magnetothermic switch (pos. 2) have also been provided in the back box.

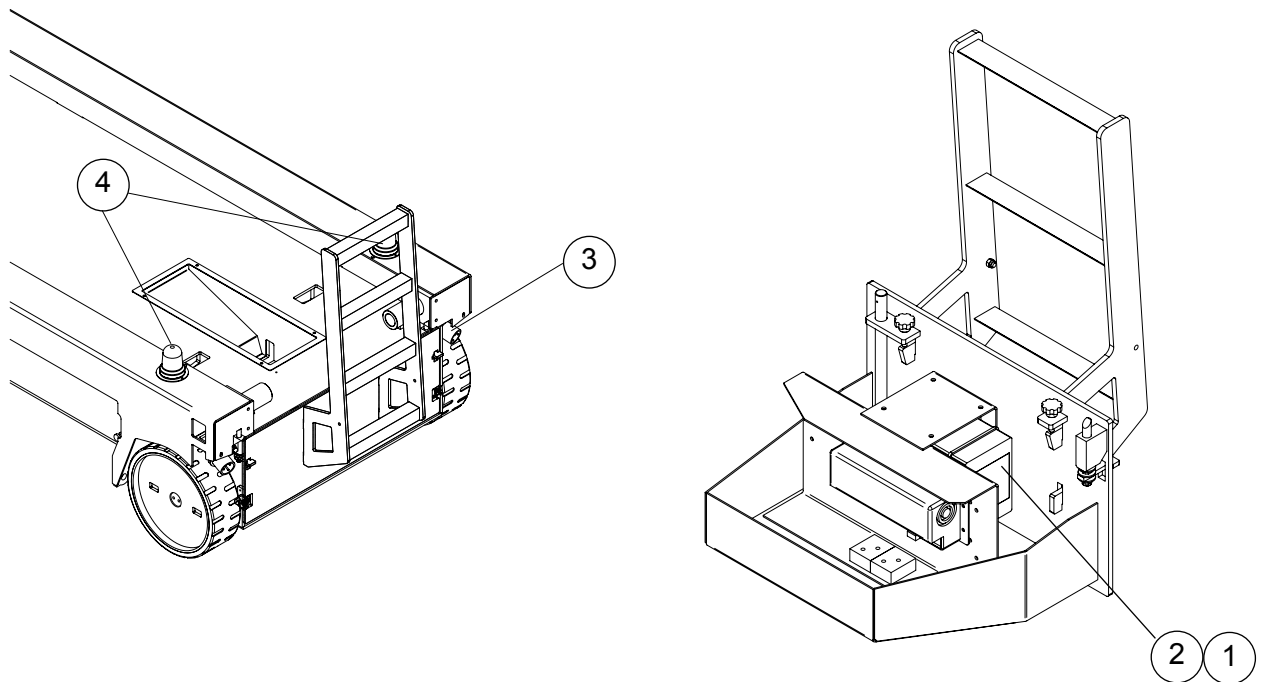

Rotating beacons

Every time the machine carries out a movement the rotating beacons (pos. 4) installed on the truck go on.

Optional

110V Line

To supply current in platform it is necessary to connect a mains cable to the right back plug.

A socket foreseen in the platform supplies current to electric instruments.

A cut-out box switch (pos. 1) and a magnetothermic switch (pos. 2) have also been provided in the back box..

Battery charger kit 110V

This kit includes all elements to recharge the batteries at 110 V.

Features

- Battery charger: 24V - 30A
 - Power supply: Dual Input (220V - 115V)
 - Voltage: 24V
 - Charge time: about 12 hours
 - Operating temperature: from -20°C to +50°C
 - Protection against output short circuit
 - Protection against polarity reversal (fuse)
 - Weight: 1.5 Kg
 - Connection to the net: standard 3 poles 115V outlet
-

Maintenance

Long life and maximum safety during operation can only be assured by careful and constant machine maintenance.

The schedule reported in the maintenance summary table refers to normal use conditions; in case of heavy working conditions (extreme temperature, polluting atmosphere, high humidity, elevation) intervals must be shorter.

Frequency and scope of periodical maintenance and inspections may depend on national rules.



Never put unintentionally in contact between them, or with the metallic frame of the machine, the electric motor or control mosfet terminals in order to avoid damages to the mosfet itself.

Machine cleaning

Once each work-shift has been finished or when you think it is necessary, clean the machine as described here below:

- Clean all surfaces by means of an air compressed blow, avoiding the formation of dirt heaps.
- Spray a normal degreasing product and eliminate the residual dirt by means of cotton clothes.



Never use diluents, scrapers and steel brushes to avoid damages to the painted surfaces.



Do not clean the machine using a jet of high-pressure water. Humidity or water penetration inside electric elements could cause failures and/or damages to the electric/electronic control elements.

Maintenance devices

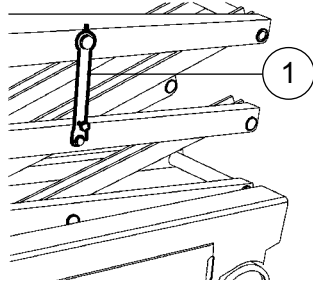

Safety rest

If the platform is subjected to maintenance while lifted, lock the lifting system on both sides by means of the suitable rests supplied with the machine (pos.1).

Use the safety supports only when platform is unloaded

Lock the lifting system as described hereafter:

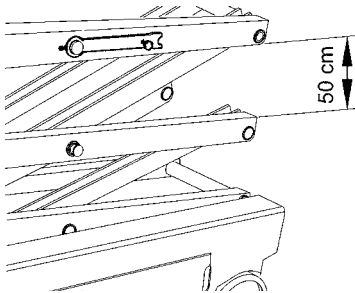

- Lift the platform so as the distance between scissors is 50 cm. approx.

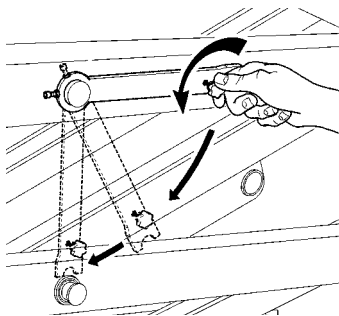

- Unscrew the knobs which block each rest (right and left) to the relevant arm, leaving them hang downwards.

- Lower the platform making sure that the lower fork of each rest (right and left) fit in the housing obtained in the central pivot extremity of the lower scissors.

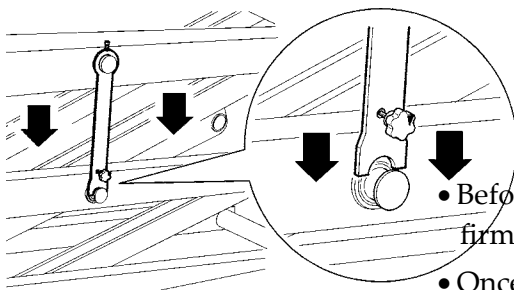

- Before starting the maintenance works, make sure that both rests are firmly rested on the side slots obtained on the pivot.
 - Once works have been finished, lift a little the platform to release the rests, and fix them again to the arm by means of locking screws.
-

Battery connection plug

The battery connection plug is placed in the left box.

This safety device disconnects the power and control circuits of batteries and the battery charger solely remains connected.



Make sure the batteries are disconnected before carrying out the electric equipment maintenance.



Maintenance summary table

OPERATION TO BE CARRIED OUT	AFTER THE FIRST 50 HOURS	EVERY DAY	MONTHLY	250 HOURS OR YEARLY	500 HOURS OR YEARLY	YEARLY	AFTER A LONG PERIOD THE MACHINE HAS NOT USED (30 days)
Check the oil level		X					X
Check the electrolyte level		X					X
Check the battery charge		X					X
Check the screw tightening	X		X				X
Grease the mechanisms			X				X
Check safety devices	X		X				X
Inspections and cleaning of batteries			X				X
Check the emergency lowering			X				X
Check motor brushes (traction and electrical pump)						X	X
Check brakes on ramp			X				X
Check structures	X			X			X
Check wheel reduction gear oil					X		X
Check the hydraulic pipe condition						X	X
Check performances						X	X

The above mentioned operations are described in the following pages.

Check oil level



The oil level checking and the possible topping up should be made when the platform is entirely lowered

Take away oil tank cap being in the hydraulic control unit; should it be necessary top up with oil of the same viscosity as indicated on the tank.

Electrolyte level check

- Open the boxes
- Take away the electrolyte supplying caps
- Check the level and if it is the case top up with distilled water
- Close caps and dry if some liquid has poured out



The sulphuric acid contained in the solution could cause serious injuries; if it is unintentionally poured, wash immediately the objects or the surfaces with abundant water.

If the acid comes into contact with the skin, wash immediately with abundant water and consult a doctor.

It is recommended to always wear gloves and protective glasses during the maintenance operations of batteries.

Check of battery charge

The battery charge level can be read on ground panel.

For the battery recharge see section "Battery recharge".

Check of screw tightening

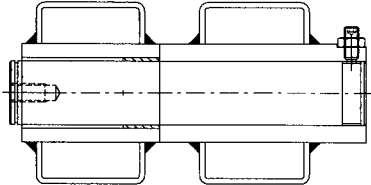
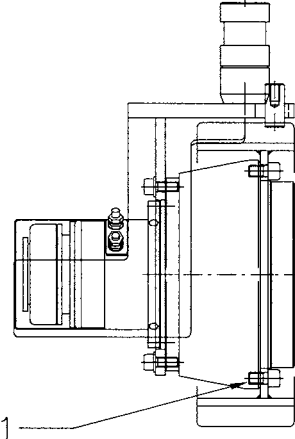
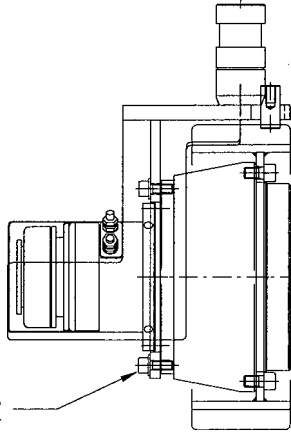
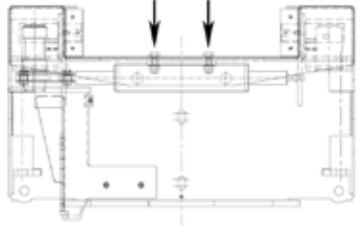
	Type	Tightening	Position
Pin screw fastener on chassis	M8X20 UNI 5929 10.9 DE M8 6S UNI 5588	2 daNm	
Wheels screw fastener	M12X20 UNI5931 12.9	11÷12 daNm	
Traction unit screw fastener (2)	M10X25 8G DIN 912	4÷5 daNm	
Steering cylinder securing screws	M14X50 UNI 5737	12daNm	

Grease the mechanisms

Two lubricators which can be seen inside the truck, are placed over the rear wheel spindles.

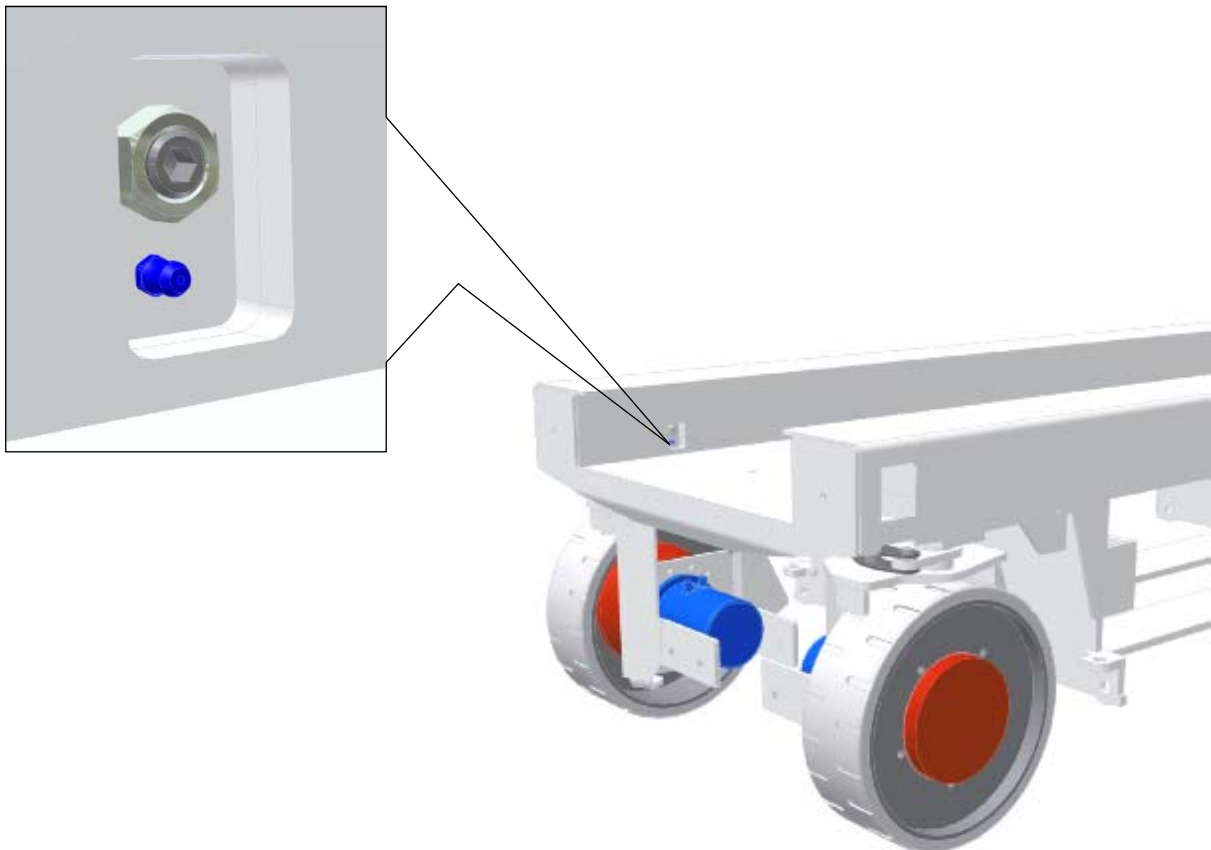

Safety check

The following test enables to check that all safety devices of the machine work properly.

The safety systems applied to the machine are inevitably subject to wear and to go out of tune. Therefore, they must be controlled and kept in perfect efficiency; also, it is not advisable to evaluate their operational and safety conditions only on the basis of their functioning.

The presence of safety systems does not relieve the operator of the responsibility of using the machine in an adequate and conscious way.

Red emergency stop push button

- Press emergency stop push button on ground control panel and check that no operation is possible, either from ground or on platform. Put push-button to ON again.
 - Press emergency stop push button on platform control panel and check that no operation is possible, either from ground or on platform. Put push-button to ON again.
-

SQ1 Microswitch

Safety speed



Make sure that there are no obstacles above or under platform before carrying out this test.

- Lift platform above microswitch SQ1 operating height from platform control panel.
- Check that drive is possible at safety speed only.

Inclination



Carry out this test with the machine perfectly levelled, for avoiding altered values.



Carry out this test by using platform control panel.



Do not stop on the platform.



Make sure that there are no obstacles above or under the platform before carrying out this test.

- Lower platform completely.
- Position a wedge A measuring about 97 mm:

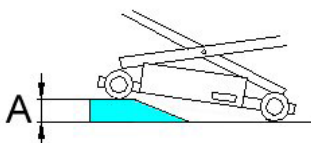

- under each wheel of front axle for rear longitudinal inclination; drive the machine on it; lift platform and carry out tests reported on the following page;
- repeat the above mentioned test positioning the wedges under each wheel of rear axle.

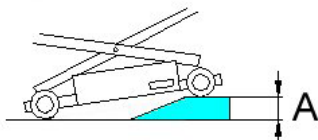

During the second test, the machine must be put in the same position with respect to the ground, while altering the wedge position (See drawing on the side).

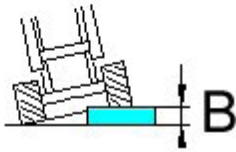
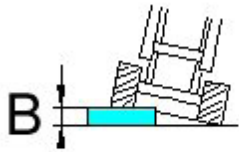

- Position a wedge B measuring about:
 - 20 mm (for model 10090), 27 mm (for models 6390 and 8290) under each left, front and rear wheel for right transversal inclination; drive machine on it; lift platform and carry out following tests.
 - repeat the above mentioned test positioning the wedges under each right front and rear wheel.

During the second test, the machine must be put in the same position with respect to the ground, while altering the wedge position (See drawing on the side).

- Check that inclination warning light blinks under SQ1 operating height
- Lift platform and check that above SQ1 operating height:
 - inclination warning light is on.
 - the alarm sounds.
 - all movements, lowering excluded, are stopped.
- Lower platform under SQ1 operating height and check that all movements have been restored.

Lower platform completely, drive machine forward and remove wedges.

Carry out tests in all four directions: forward – backward – rightward – leftward.

Protections against overturning

During normal machine operation, the protections against overturning automatically lower when platform is lifted and they are completely lowered when the platform reaches the SQ1 operating height; on the contrary, traction and steering are blocked.

- Lower platform completely.
 - Place an obstacle of 30 mm under one of the protections against overturning to avoid its lowering.
-

- Lift the platform above SQ5 operating height
- Check that drive and steering movements are deactivated.
- Check that the protections against overturning pilot light on the platform control panel and audible alarm go on.
- Lower the platform and remove the obstacle.
- Repeat the check on the other protection.

Load limiting device

- Load platform with a load equal to 120% the nominal value.
- Check that by operating platform lifting :
 - the excess load warning light on platform control panel switches on.
 - the excess load warning light on ground control panel switches on.
 - the alarm sounds
 - all movements are stopped.
- Remove excess load.
- Check that all movements are restored.

Antishearing operations



Make sure that there are no obstacles above or under platform before carrying out this test

- Lift platform by 2 meters.
 - Lower platform and check that lowering is stopped when distance between arm and frame ends is approx. 60 mm. After a time interval of 5 ÷ 6 seconds, put the joystick in standstill position and continue the lowering.
 - Check that lowering remains inhibited even if you move the joystick for the lowering before the indicated time interval has passed.
-

Battery inspection and cleaning



Disconnect battery connecting plug before carrying out the tests.

Batteries must be periodically inspected for checking that there are no damages, breakages, fluid leakages or terminal corrosion. Also inspect cables looking for breakages, cuts or fraying.

Always clean batteries that show signs of corrosion on terminals or onto which electrolytic fluid has fallen during filling.

Always clean terminal contact surfaces, lubricate with antacid grease or vaseline.



The battery fluid is highly corrosive and can cause severe injuries; if it is poured unintentionally, wash objects or surfaces with abundant water.

If the acid comes into contact with the skin, wash immediately with abundant water and consult a doctor.

Always wear gloves and goggles during battery maintenance.

Keep open flames, cigarettes, sparks or any other flammable source away from batteries.

Emergency lowering check



Make sure that there are no obstacles under the platform before executing this control

- Lift platform.
 - Carry out operations indicated in the section “Emergency lowering” checking the correct operation of the emergency lowering.
-

Engine brushes check

Check brush wear of traction electric motors and electrical pump motor; replace if necessary.

Check of brakes on ramp

Parking brakes must be capable to stop the machine on max. slope indicated in the "Technical data" table.

Check that brakes stops on a slope indicated in the above mentioned table.

Braking spaces

All tests must be executed with the machine flat.

FAST SPEED

- Select fast speed on platform control panel.
 - Push joystick to max forward position.
 - Release joystick and check that the braking space is lower than 60 cm.
-

Structure check

General

- Check that mechanical structures are protected against oxidation and, if necessary, retouch oxidized area.

Base truck

- Check the most important welds visually or by means of penetrating fluids:
 - Bearing structure.
 - Spindles of steering wheels.
 - Wheel supports.
 - Scissor hinging supports.
- Check the shape of the guide profiles for the sliding blocks.
- Check that steering bar is in its correct position and that it is fastened to the spindles and to the steering actuator.
- Check trunnions on spindles and steering actuator and bar.
- Check bushes; replace them by using lubricating grease if necessary.
- Check tyre conditions.

Platform

- Check the most important welds visually or by means of penetrating fluids:
 - Tubular structures.
 - Hinging supports.
- Visually inspect operational top conditions of both stationary platform and extension.
- Check the shape of guide profile for sliding blocks.
- Check sliding blocks.
- Visually check railings and their fastening.

Machine frame

- Visual inspection of its integrity and of the shape of booms and frames.
 - Check, visually or by means of penetrating fluids, all welds of articulation bushes, lifting cylinder attachments, and welds on cylinder.
 - Check fastening of trunnions and hinging pins of lifting cylinder.
 - Check surface conditions of trunnions and bushes; replace if necessary, by utilizing lubricating grease.
-

Check of wheel reduction gear oil

- Move the front wheel on the horizontal surface having the two level caps (pos. 1) aligned.
- Unscrew one of the two caps (pos. 1): oil must be flush with the hole.
- If necessary, fill up with oil type SAE 80 W - 90.
- Total capacity 0.4 litres.

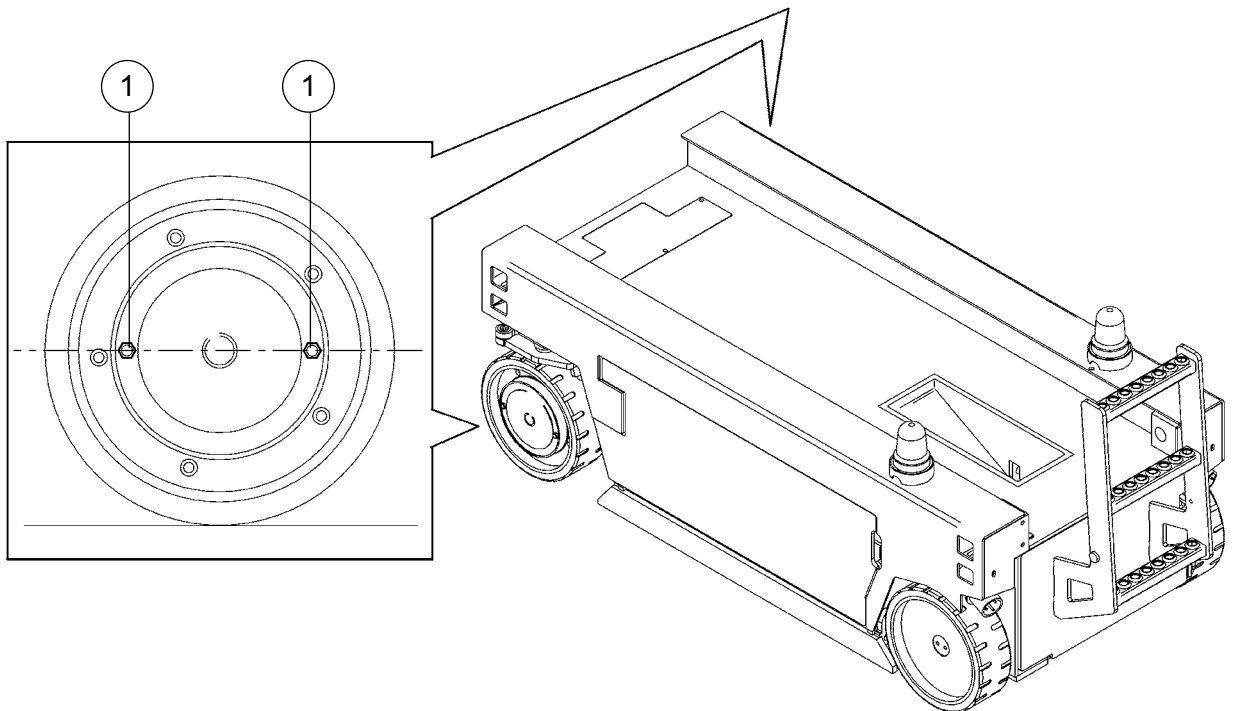

Check of hydraulic tubes



Hydraulic oil is a polluting product.

Avoid fluid leakages by using collection tanks and take precautions against accidental leakages by resorting to oil-absorbing products.

- Visual control of all hydraulic joints and tighten junctions, if necessary.
- Check conditions of flexible hydraulic tubes; replace if necessary.

Replacing hydraulic oil



Hydraulic oil is a polluting product.

Avoid fluid leakages by using collection tanks and take precautions against accidental leakages by resorting to oil-absorbing products.



Exhausted oil must be collected and not disposed of into normal discharge lines; specialized firms attend to dispose of or possibly recycle industrial oils, under the laws prevailing in each individual state.

A cap is located under the tank for total oil discharge.

- Discharge all oil from tank.
- Close discharge cap.
- Fill in new oil through filling cap.

Checking performance

Use a chronometer for executing the following controls.

All tests must be executed with the machine flat.

Safety speed

- Select safety speed on platform control panel.
 - Push joystick to max forward position.
 - Check that machine covers 10 m in a time greater than 50 sec.
-

Steering speed

- Select safety speed.
 - Steer wheels rightward completely.
 - Execute drive and steer leftward completely.
 - Check that time necessary to steer from right to left is 6 ÷ 8 sec.
-

This page has purposely been left blank.

Check register

Reference to legislation

This check register is issued by ITECO S.p.a for aerial platform users, as envisaged by Enclosure I of 98/37/EC guideline.

Instructions for keeping this register

This check register must be considered as an integral part of the aerial platform and must be kept with the platform for its whole life, until it is finally dismantled.

Instructions for compilation

These instructions are supplied based on provisions that are already known at the date the aerial platform is first marketed. New provisions might be issued which could change the user's obligations.

This register is prearranged for recording the following events related to the useful life of the aerial platform, based on proposed diagrams:

Delivery of aerial platform to the first owner.

- Changes of ownership.
- Replacement of components of the hydraulic system.
- Replacement of components of the electric system.
- Replacement of mechanisms or structural elements.
- Replacement of safety devices and their components.
- Periodical maintenance verification except daily inspections indicated in the maintenance summary table.
- Remarkable failures and their repair.

PLATFORM DELIVERY TO THE FIRST OWNER

The aerial platform type _____ , with factory number: _____ and construction year _____ referred to in this check register has been delivered by _____ to Messrs:

on _____

according to the terms agreed upon in the contract, with the technical, size and functional characteristics specified in the Operating Handbook.

SUBSEQUENT CHANGES OF OWNERSHIP

On _____

The ownership of the aerial platform mentioned above is transferred to the Firm/Company:

It is hereby certified that on the date mentioned above the technical, dimensional and functional characteristics of this aerial platform are consistent with the originally envisaged ones and that changes, if any, have been reported in this Register.

The Seller

The Buyer

SUBSEQUENT CHANGES OF OWNERSHIP

On _____

The ownership of the aerial platform mentioned above is transferred to the Firm/Company:

It is hereby certified that on the date mentioned above the technical, dimensional and functional characteristics of this aerial platform are consistent with the originally envisaged ones and that changes, if any, have been reported in this Register.

The Seller

The Buyer

REPLACEMENT OF COMPONENTS IN THE HYDRAULIC SYSTEM

On the date _____
the piece _____
fabricated _____
HAS BEEN REPLACED
with _____
fabricated _____ factory Nr. _____
note _____
Cause of replacement _____

The officer of the firm entrusted with the replacement _____ The user _____

REPLACEMENT OF COMPONENTS IN THE HYDRAULIC SYSTEM

On the date _____
the piece _____
fabricated _____
HAS BEEN REPLACED
with _____
fabricated _____ factory Nr. _____
note _____
Cause of replacement _____

The officer of the firm entrusted with the replacement _____ The user _____

REPLACEMENT OF COMPONENTS IN THE HYDRAULIC SYSTEM

On the date _____
the piece _____
fabricated _____
HAS BEEN REPLACED
with _____
fabricated _____ factory Nr. _____
note _____

Cause of replacement _____

The officer of the firm entrusted with the replacement _____ The user _____

REPLACEMENT OF COMPONENTS IN THE ELECTRIC SYSTEM

On the date _____
the piece _____
fabricated _____
HAS BEEN REPLACED
with _____
fabricated _____ factory Nr. _____
note _____
Cause of replacement _____

The officer of the firm entrusted with the replacement _____ The user _____

REPLACEMENT OF COMPONENTS IN THE ELECTRIC SYSTEM

On the date _____
the piece _____
fabricated _____
HAS BEEN REPLACED
with _____
fabricated _____ factory Nr. _____
note _____
Cause of replacement _____

The officer of the firm entrusted with the replacement _____ The user _____

REPLACEMENT OF COMPONENTS IN THE ELECTRIC SYSTEM

On the date _____
the piece _____
fabricated _____
HAS BEEN REPLACED
with _____
fabricated _____ factory Nr. _____
note _____
Cause of replacement _____

The officer of the firm entrusted with the replacement _____ The user _____

REPLACEMENT OF GEARS OR STRUCTURAL COMPONENTS

On the date _____

the piece _____

fabricated _____

HAS BEEN REPLACED

with _____

fabricated _____ factory Nr. _____

note _____

Cause of replacement _____

The officer of the firm entrusted with the replacement

The user

REPLACEMENT OF GEARS OR STRUCTURAL COMPONENTS

On the date _____

the piece _____

fabricated _____

HAS BEEN REPLACED

with _____

fabricated _____ factory Nr. _____

note _____

Cause of replacement _____

The officer of the firm entrusted with the replacement

The user

REPLACEMENT OF GEARS OR STRUCTURAL COMPONENTS

On the date _____

the piece _____

fabricated _____

HAS BEEN REPLACED

with _____

fabricated _____ factory Nr. _____

note _____

Cause of replacement

The officer of the firm entrusted with the replacement

The user

REPLACEMENT OF SAFETY DEVICES AND RELEVANT COMPONENTS

On the date _____
the piece _____
fabricated _____
HAS BEEN REPLACED
with _____
fabricated _____ factory Nr. _____
note _____
Cause of replacement _____

The officer of the firm entrusted with the replacement _____ The user _____

REPLACEMENT OF SAFETY DEVICES AND RELEVANT COMPONENTS

On the date _____
the piece _____
fabricated _____
HAS BEEN REPLACED
with _____
fabricated _____ factory Nr. _____
note _____
Cause of replacement _____

The officer of the firm entrusted with the replacement _____ The user _____

REPLACEMENT OF SAFETY DEVICES AND RELEVANT COMPONENTS

On the date _____
the piece _____
fabricated _____
HAS BEEN REPLACED
with _____
fabricated _____ factory Nr. _____
note _____
Cause of replacement _____

The officer of the firm entrusted with the replacement _____ The user _____

VERIFICATION OF PERIODICAL MAINTENANCE

The user must comply with the maintenance and surveillance obligation described in this operating handbook.

NR.	Date	Description of intervention	GNATUR
1			
2			
3			
4			
5			
6			
7			
8			
9			
10			
11			
12			
13			
14			
15			
16			
17			
18			
19			
20			

NR.	Date	Description of intervention	GNATUR
21			
22			
23			
24			
25			
26			
27			
28			
29			
30			
31			
32			
33			
34			
35			
36			
37			
38			
39			
40			

NR.	Date	Description of intervention	GNATUR
41			
42			
43			
44			
45			
46			
47			
48			
49			
50			
51			
52			
53			
54			
55			
56			
57			
58			
59			
60			

IMPORTANT SAUNDRIES AND THEIR REPAIR

Description of failure _____

Causes _____

Repair carried out _____

Signature of the official of servicing firm

User's signature

Place _____

Date _____



IMPORTANT SAUNDRIES AND THEIR REPAIR

Description of failure _____

Causes _____

Repair carried out _____

Signature of the official of servicing firm

User's signature

Place _____

Date _____

IMPORTANT SAUNDRIES AND THEIR REPAIR

Description of failure _____

Causes _____

Repair carried out _____

Signature of the official of servicing firm _____

User's signature _____

Place _____

Date _____



IMPORTANT SAUNDRIES AND THEIR REPAIR

Description of failure _____

Causes _____

Repair carried out _____

Signature of the official of servicing firm _____

User's signature _____

Place _____

Date _____

IT6390
CS A00257CS
DE A00257DE
DK A00257DK
ES A00257ES
FN A00257FN
FR A00257FR
GB A00257GB
IT A00257IT
NL A00257NL
NO A00257NO
PL A00257PL
PT A00257PT
SE A00257SE

IT8290
CS A00253CS
DE A00253DE
DK A00253DK
ES A00253ES
FN A00253FN
FR A00253FR
GB A00253GB
IT A00253IT
NL A00253NL
NO A00253NO
PL A00253PL
PT A00253PT
SE A00253SE

IT10090
CS A00218CS
DE A00218DE
DK A00218DK
ES A00218ES
FN A00218FN
FR A00218FR
GB A00218GB
IT A00218IT
NL A00218NL
NO A00218NO
PL A00218PL
PT A00218PT
SE A00218SE

IT 6390 A00248xx
IT 8290 A00249xx
IT 10090 A00250xx

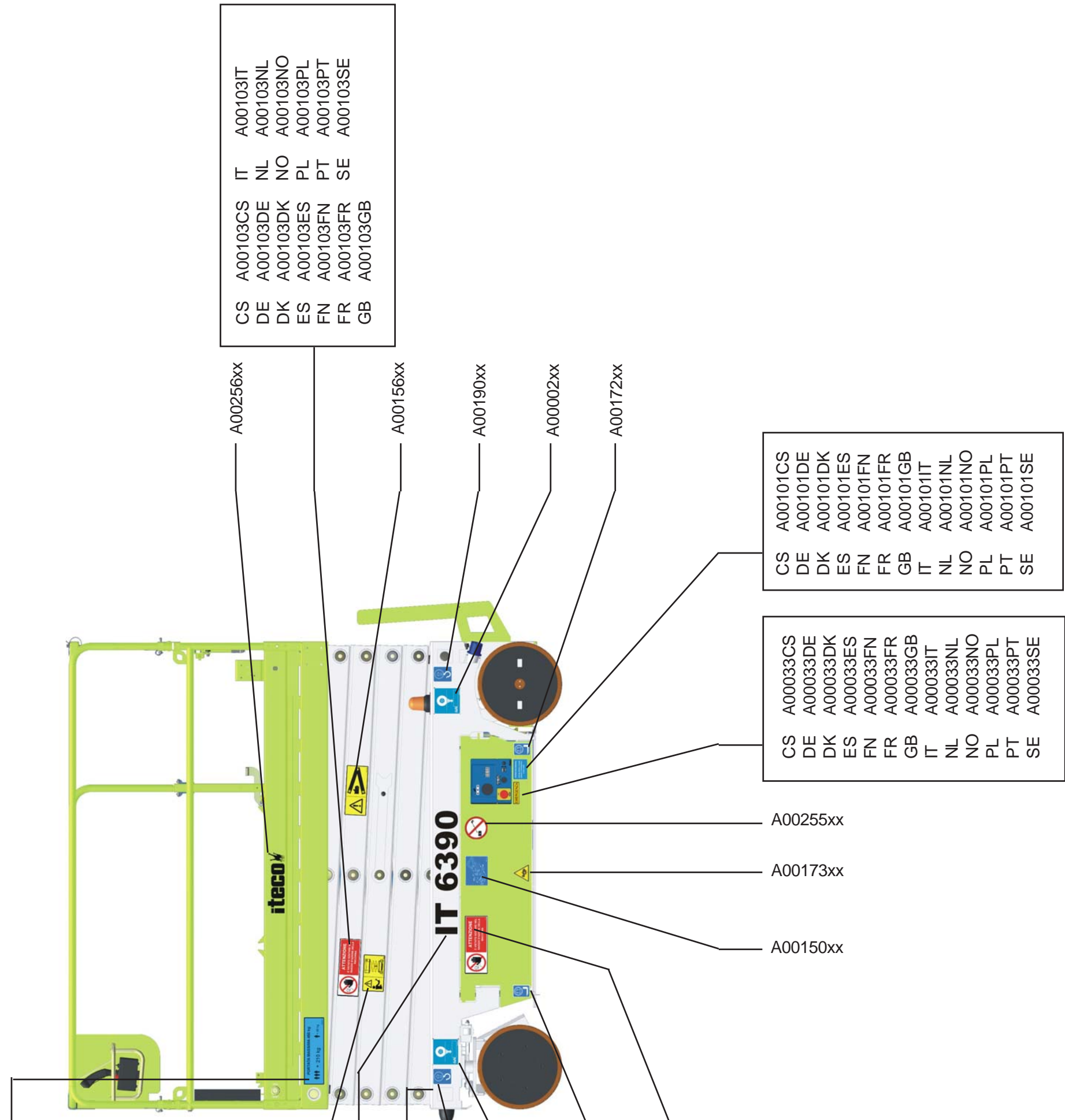

CS	A00103CS	IT	A00103IT
DE	A00103DE	NL	A00103NL
DK	A00103DK	NO	A00103NO
ES	A00103ES	PL	A00103PL
FN	A00103FN	PT	A00103PT
FR	A00103FR	SE	A00103SE
GB	A00103GB		

CS	A00101CS
DE	A00101DE
DK	A00101DK
ES	A00101ES
FN	A00101FN
FR	A00101FR
GB	A00101GB
IT	A00101IT
NL	A00101NL
NO	A00101NO
PL	A00101PL
PT	A00101PT
SE	A00101SE

CS	A00033CS
DE	A00033DE
DK	A00033DK
ES	A00033ES
FN	A00033FN
FR	A00033FR
GB	A00033GB
IT	A00033IT
NL	A00033NL
NO	A00033NO
PL	A00033PL
PT	A00033PT
SE	A00033SE

CS	A00103CS
DE	A00103DE
DK	A00103DK
ES	A00103ES
FN	A00103FN
FR	A00103FR
GB	A00103GB
IT	A00103IT
NL	A00103NL
NO	A00103NO
PL	A00103PL
PT	A00103PT
SE	A00103SE

IT 6390
A00257CS
A00257DE
A00257DK
A00257ES
A00257FN
A00257FR
A00257GB
A00257IT
A00257NL
A00257NO
A00257PL
A00257PT
A00257SE

IT 8290
A00253CS
A00253DE
A00253DK
A00253ES
A00253FN
A00253FR
A00253GB
A00253IT
A00253NL
A00253NO
A00253PL
A00253PT
A00253SE

IT 10090
A00218CS
A00218DE
A00218DK
A00218ES
A00218FN
A00218FR
A00218GB
A00218IT
A00218NL
A00218NO
A00218PL
A00218PT
A00218SE

CS	A00103CS
DE	A00103DE
DK	A00103DK
ES	A00103ES
FN	A00103FN
FR	A00103FR
GB	A00103GB
IT	A00103IT
NL	A00103NL
NO	A00103NO
PL	A00103PL
PT	A00103PT
SE	A00103SE

IT 6390
A00248xx
IT 8290
A00249xx
IT 10090
A00250xx

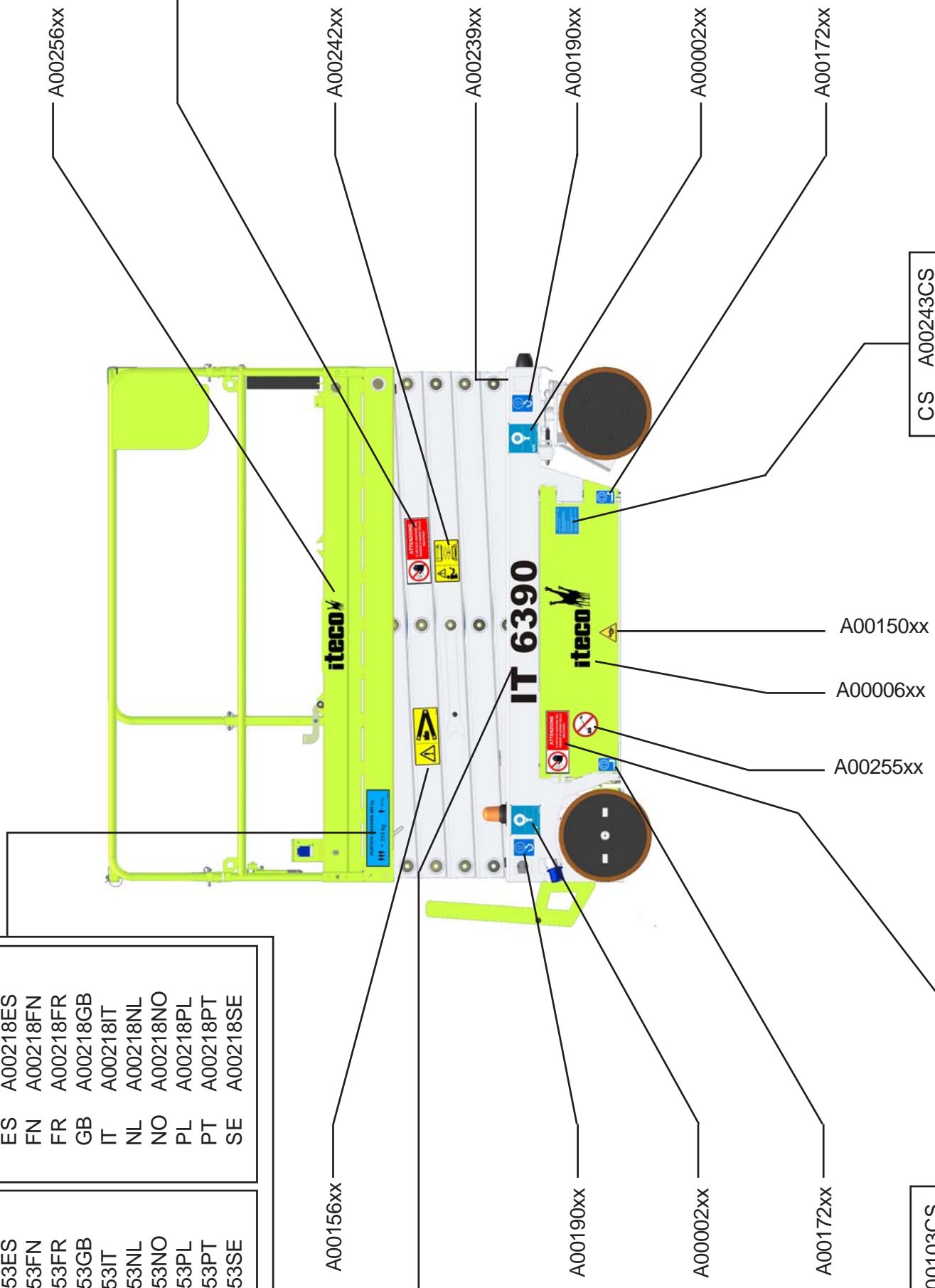

CS	A00103CS
DE	A00103DE
DK	A00103DK
ES	A00103ES
FN	A00103FN
FR	A00103FR
GB	A00103GB
IT	A00103IT
NL	A00103NL
NO	A00103NO
PL	A00103PL
PT	A00103PT
SE	A00103SE

CS	A00243CS
DE	A00243DE
DK	A00243DK
ES	A00243ES
FN	A00243FN
FR	A00243FR
GB	A00243GB
IT	A00243IT
NL	A00243NL
NO	A00243NO
PL	A00243PL
PT	A00243PT
SE	A00243SE

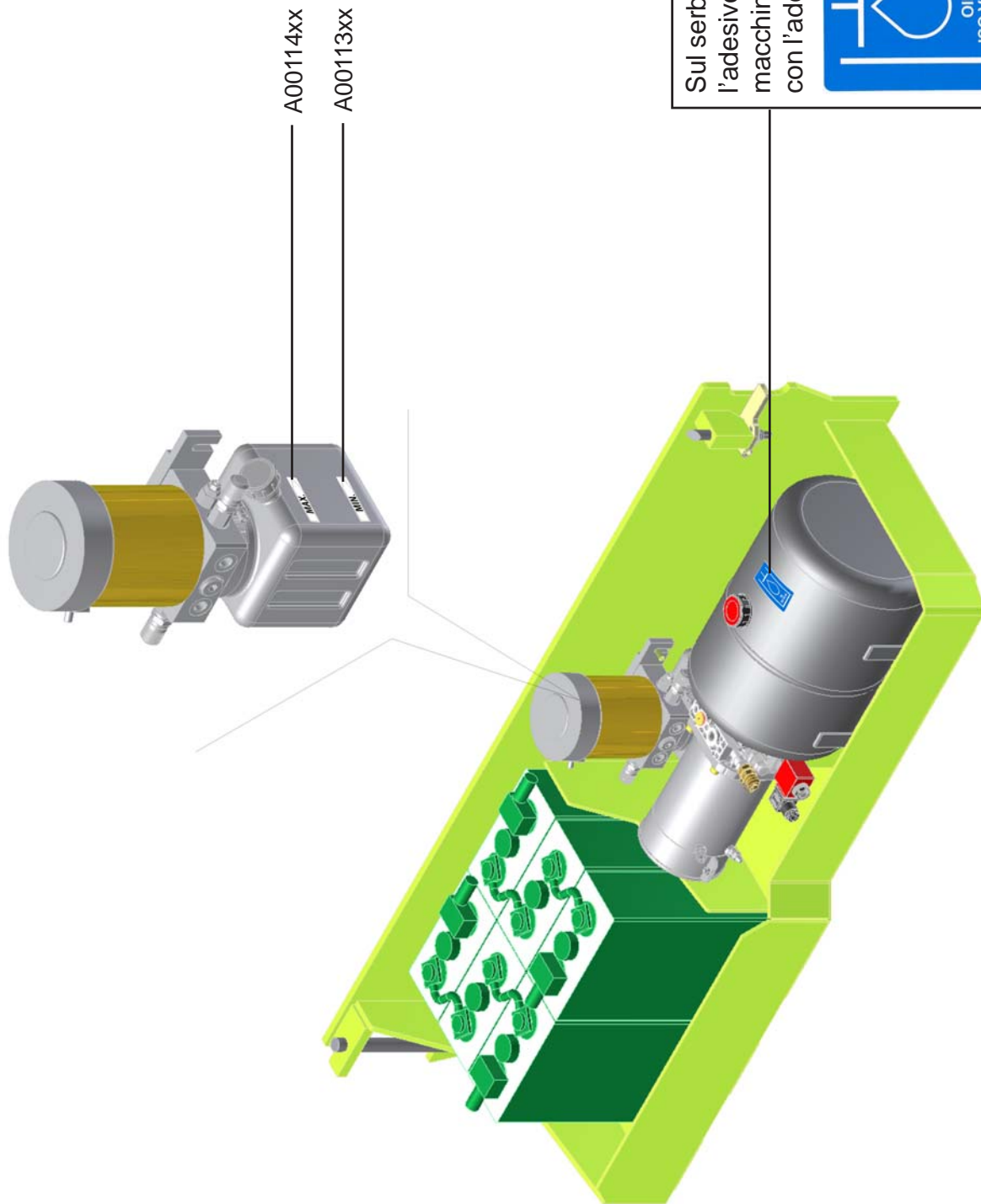

Sul serbatoio dell'olio applicare
l'adesivo A00174xx; solo per le
macchine FINLANDIA sostituirlo
con l'adesivo A00189xx



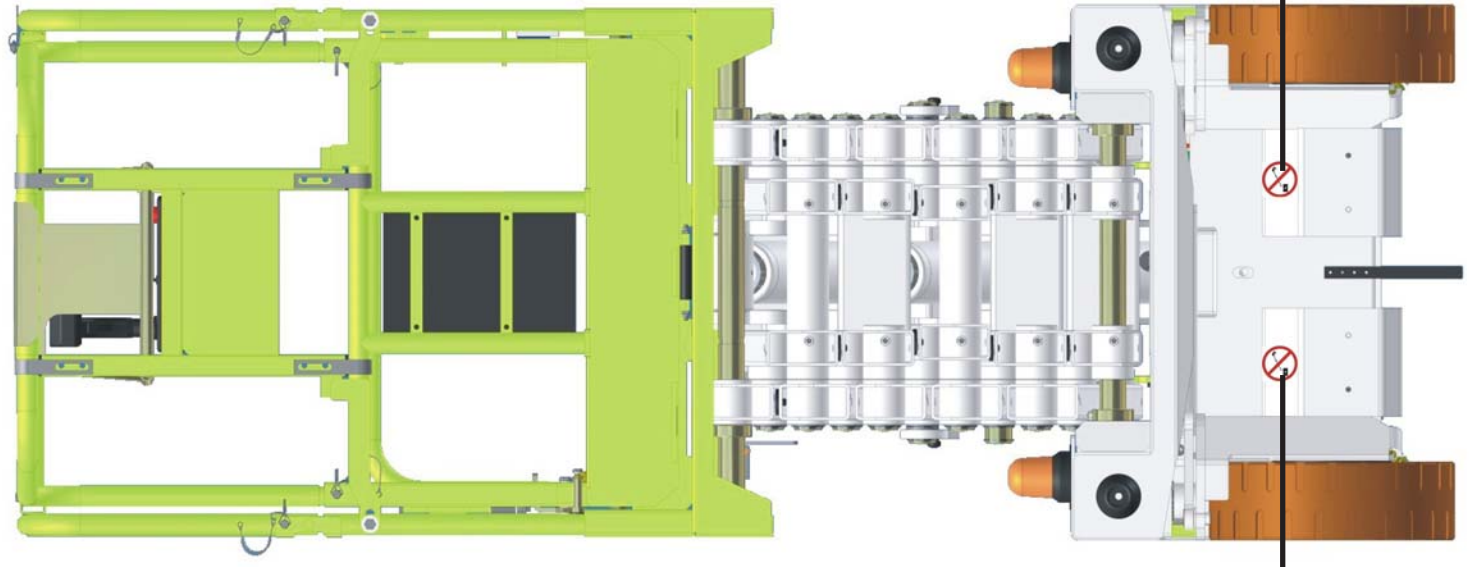

A00255xx

A00255xx

IT6390
 CS A00257CS
 DE A00257DE
 DK A00257DK
 ES A00257ES
 FN A00257FN
 FR A00257FR
 GB A00257GB
 IT A00257IT
 NL A00257NL
 NO A00257NO
 PL A00257PL
 PT A00257PT
 SE A00257SE

IT8290
 CS A00253CS
 DE A00253DE
 DK A00253DK
 ES A00253ES
 FN A00253FN
 FR A00253FR
 GB A00253GB
 IT A00253IT
 NL A00253NL
 NO A00253NO
 PL A00253PL
 PT A00253PT
 SE A00253SE

IT10090
 CS A00218CS
 DE A00218DE
 DK A00218DK
 ES A00218ES
 FN A00218FN
 FR A00218FR
 GB A00218GB
 IT A00218IT
 NL A00218NL
 NO A00218NO
 PL A00218PL
 PT A00218PT
 SE A00218SE

CS A00047CS
 DE A00047ES
 DK A00047DK
 ES A00047ES
 FN A00047FN
 FR A00047FR
 GB A00047GB
 IT A00047IT
 NL A00047NL
 NO A00047NO
 PL A00047PL
 PT A00047PT
 SE A00047SE

CS A00031CS
 DE A00031ES
 DK A00031DK
 ES A00031ES
 FN A00031FN
 FR A00031FR
 GB A00031GB
 IT A00031IT
 NL A00031NL
 NO A00031NO
 PL A00031PL
 PT A00031PT
 SE A00031SE

CS A00105CS
 DE A00105DE
 DK A00105DK
 ES A00105ES
 FN A00105FN
 FR A00105FR
 GB A00105GB
 IT A00105IT
 NL A00105NL
 NO A00105NO
 PL A00105PL
 PT A00105PT
 SE A00105SE

A00001xx

A00109xx

A00270xx

A00254xx

A00110xx

A00260xx

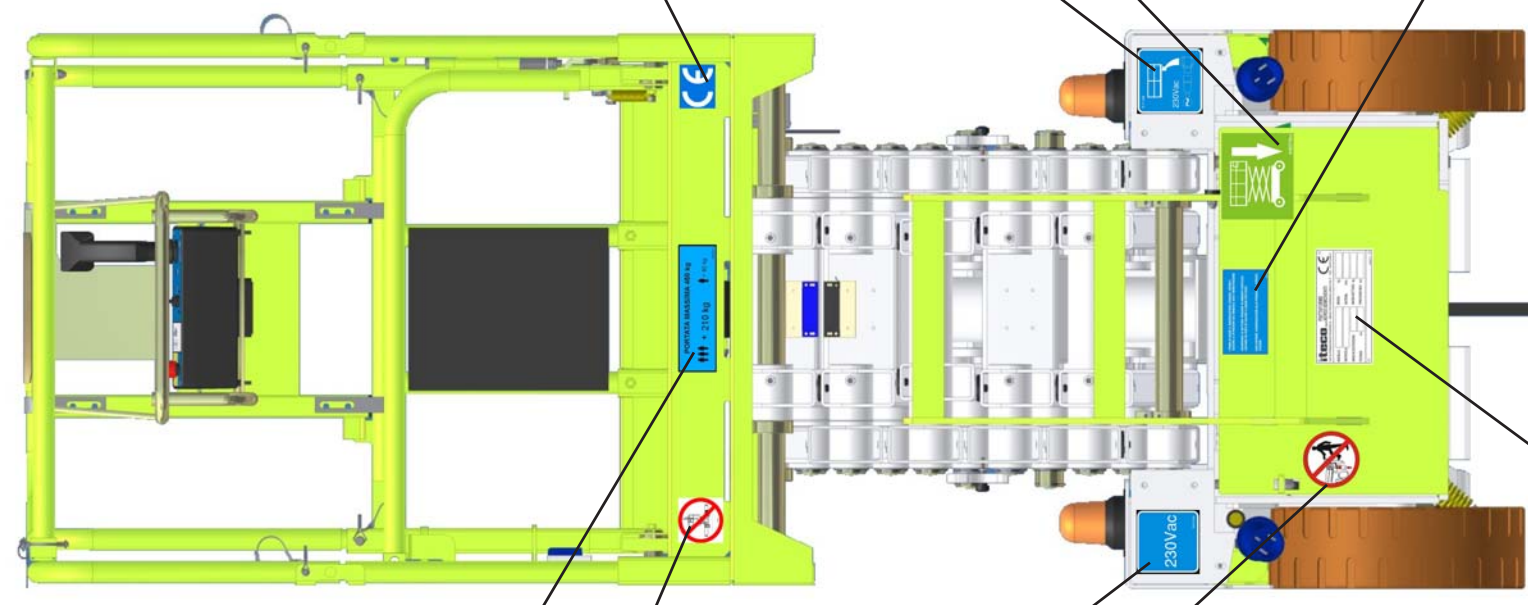
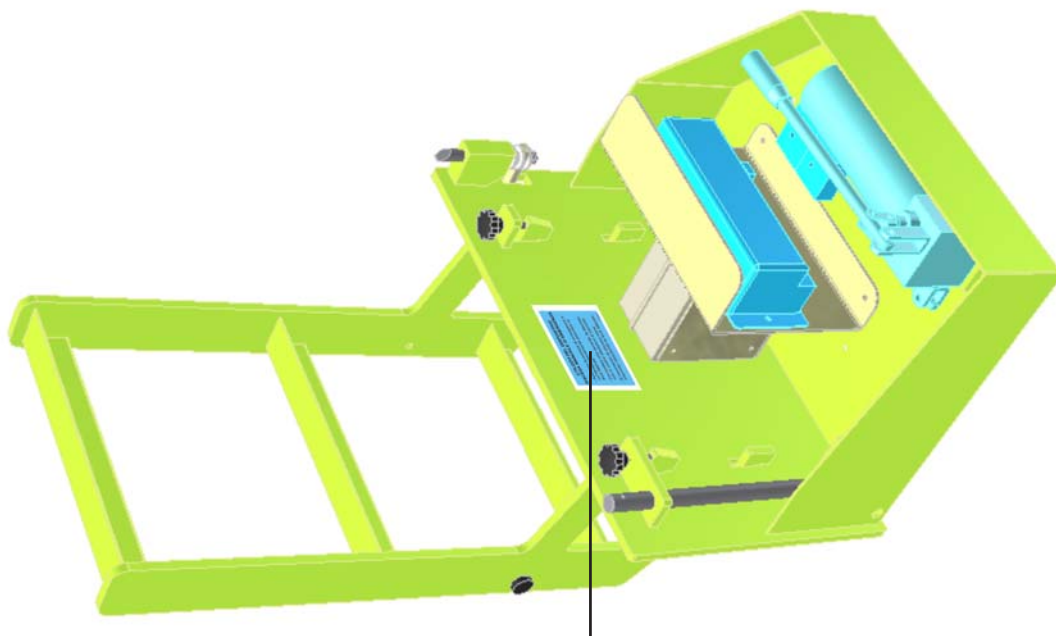

CS	A00153CS
DE	A00153ES
DK	A00153DK
ES	A00153ES
FN	A00153FN
FR	A00153FR
GB	A00153GB
IT	A00153IT
NL	A00153NL
NO	A00153NO
PL	A00153PL
PT	A00153PT
SE	A00153SE

IT6390	
CS	A00257CS
DE	A00257DE
DK	A00257DK
ES	A00257ES
FN	A00257FN
FR	A00257FR
GB	A00257GB
IT	A00257IT
NL	A00257NL
NO	A00257NO
PL	A00257PL
PT	A00257PT
SE	A00257SE

IT8290	
CS	A00253CS
DE	A00253DE
DK	A00253DK
ES	A00253ES
FN	A00253FN
FR	A00253FR
GB	A00253GB
IT	A00253IT
NL	A00253NL
NO	A00253NO
PL	A00253PL
PT	A00253PT
SE	A00253SE

IT10090	
CS	A00218CS
DE	A00218DE
DK	A00218DK
ES	A00218ES
FN	A00218FN
FR	A00218FR
GB	A00218GB
IT	A00218IT
NL	A00218NL
NO	A00218NO
PL	A00218PL
PT	A00218PT
SE	A00218SE



A00215xx

A00145xx

A00201xx

CS	A00005CS
DE	A00005DE
DK	A00005DK
ES	A00005ES
FN	A00005FN
FR	A00005FR
GB	A00005GB
IT	A00005IT
NL	A00005NL
NO	A00005NO
PL	A00005PL
PT	A00005PT
SE	A00005SE

A00201xx

CS A00106CS
DE A00106DE
DK A00106DK
ES A00106ES
FN A00106FN
FR A00106FR
GB A00106GB
IT A00106IT
NL A00106NL
NO A00106NO
PL A00106PL
PT A00106PT
SE A00106SE

A00032xx

A00216xx

