

SJ86 T

TELESCOPIC BOOM



STANDARD FEATURES

- EASYDRIVE™ Direction sensing drive and steer controls
- AXLDRIIVE™ Axle-based 4WD system
- Operator controlled locking rear differential and limited slip front differential
- Oscillating steer axle
- Drivable at full height
- 45% Gradeability
- Wet disc SAHR brakes (front and rear axle)
- 18 x 625 Grip lug foam-filled tyres
- Relay based control system
- Standard Skyjack colour coded and numbered wiring
- Stage V diesel engine
- Swing out engine tray
- Swing up cowlings for easy access
- Proportional joystick controls and speed selector for platform toggle switch controls
- 227 / 341 kg Dual capacity
- 0.91 x 2.44 m Platform
- Bolt-in platform railings
- Lanyard attachment points
- Tri-entry sliding mid rails
- Secondary Guarding Electrical (SGE)
- Overload sensing system
- Wiring for AC outlet on platform
- Tilt alarm (5.0° x 5.0°) with drive and lift cut-out
- Single point emergency lowering
- 360° Continuous turret rotation
- Tie down/lifting lugs
- Hourmeter
- Operator horn
- Lockable power disconnect switch

OPTIONS

- Glazier kit
- Pipe rack
- Tool caddy
- Flashing light
- All motion audible alarm
- Rear spring hinged entry gate
- Auxiliary top rail (0.91 x 2.44 m Platform only)
- 3.5 kW generator (Includes hydraulic oil cooler)
- Deutz D2011L04i Diesel engine (export only)
- Hydraulic oil cooler
- Bio oil
- Control box cover
- Grip lug foam-filled non-marking tyres
- Hostile environment package (includes cylinder bellows, boom wipers, covers for the fly boom cutouts, and control box cover)
- Lifting lugs
- ELEVATE telematics

† Standard lead times may be increased when optional equipment is added, consult factory.
‡ Capacities and machine weights may differ when options are added.

SJ86 T TELESCOPIC BOOM

Dimensions	SJ86 T
Work Height	28.21 m
Platform Height	26.21 m
Horizontal Reach	23.42 m
Working Reach	24.07 m
A Platform Size	0.91 x 2.44 m
B Stowed Width	2.49 m
C Tailswing	1.42 m
D Stowed Height	3.00 m
E Transportation Height	3.13 m
F Stowed Length	12.95 m
G Transportation Length	10.59 m
H Wheelbase	3.35 m
I Ground Clearance	0.41 m
Specifications	SJ86 T
Rotation	360°
Platform Rotation	170°
Jib Length	1.68 m
Jib Range +/-	+65° / -60°
Weight	17,237 kg
Gradeability	45%
Turning Radius (Inside)	3.51 m
Turning Radius (Outside)	6.40 m
Axle Oscillation	10.16 cm
Drive Speed (High speed)	4.8 km/h
Capacity	227 kg / 341 kg
Local Floor Load (With Rated Load)	12.34 kg/sq cm
Overall Floor Load (With Rated Load)	1,632 kg/sq m
Maximum # of persons up to 12.5 m/s wind rating	2 / 3
Tyre Type	Foam-Filled
Tyre Size	18-625
Diesel Engine	Deutz TCD2.2L - 74 HP (55 KW)
Fuel Tank Capacity	170 L
Hydraulic Reservoir	227 L

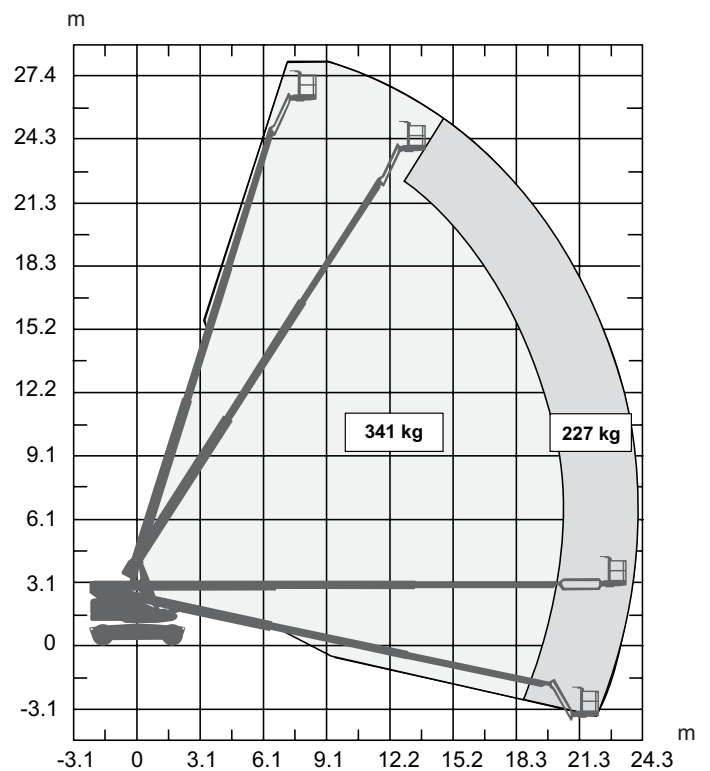
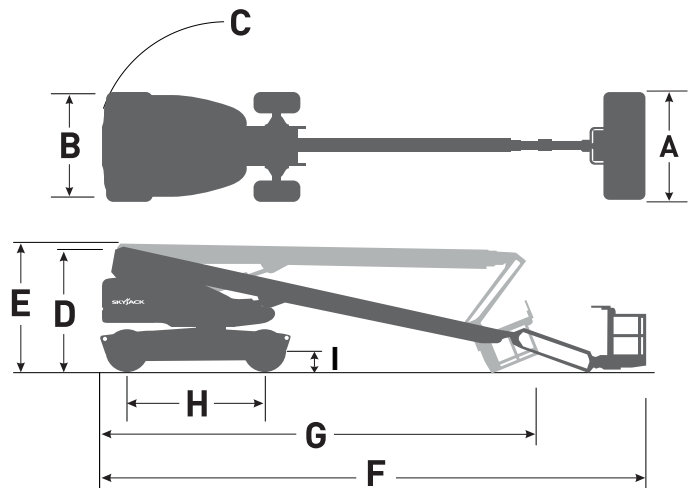

SJ86 T WORKING ENVELOPE

www.skyjack.com

Skyjack UK
Unit 1, Maes-y-Clawdd
Maesbury Road Industrial Estate
Oswestry, Shropshire, SY10 8NN
Tel: +44 1691 676235
Fax: +44 1691 676239
Email: info@skyjackeurope.co.uk

Skyjack SAS (France)
74 Rue Sibert
F-42400 Saint Chamond
France
Tel: +33 (0) 4 78 73 53 32
Fax: +33 (0) 4 78 56 52 42

Skyjack Hebebühnen GmbH
(Germany)
Därmanbusch 2a
D-58456 Witten
Tel: +49 (0) 2302 20 26 909
Fax: +49 (0) 2302 20 25 671

Skyjack AB (Sweden)
Agnesbergsvägen 28
424 38 Agnesberg
Sweden
Tel: +46 (0) 31 21 22 45
Fax: +46 (0) 31 787 65 10

SKYJACK
simply reliable