

Speed Level Plus

SL26/30SL

Dimensions	SL26	SL30
Max. working height	10.0m	11.0m
Max. platform height (A)	8.0m	9.0m
Platform size (stowed)	1.72m x 3.66m	1.72m x 4.23m
Platform size (extended)	1.72m x 4.23m	n/a
Overall width (D)	2.13m	2.13m
Overall length (C)	3.79m	4.39m
Stowed height (B)	2.6m	2.6m
Min. height (guardrails folded)	1.1m	1.1m
Chassis ground clearance	320mm	320mm
Axle ground clearance	200mm	200mm

Performance		
Platform capacity (SWL)	725kg	650kg
Max. drive height	8.0m	9.0m
Max. drive speed (stowed)	5.2km/h	5.2km/h
Max. drive speed (elevated)	0.8km/h	0.8km/h
Raise/lower time	21/32 sec	24/36 sec
Gradeability	27° / 50%	27° / 50%
Max. levelling, front to back	9°	9°
Max. levelling, side to side	13°	13°
Inside turning radius	3.9m	3.9m
Tyres	26 x 12.00 - 12 NHS Supa Terra-Grip, poly filled	
Controls	Proportional joystick	
Drive system	4 wheel drive with hydraulic motors and flow dividers	

Power	
Power source	Perkins diesel, water cooled engine

Weight		
Gross weight	3,085kg	3,151kg

levelling capabilities

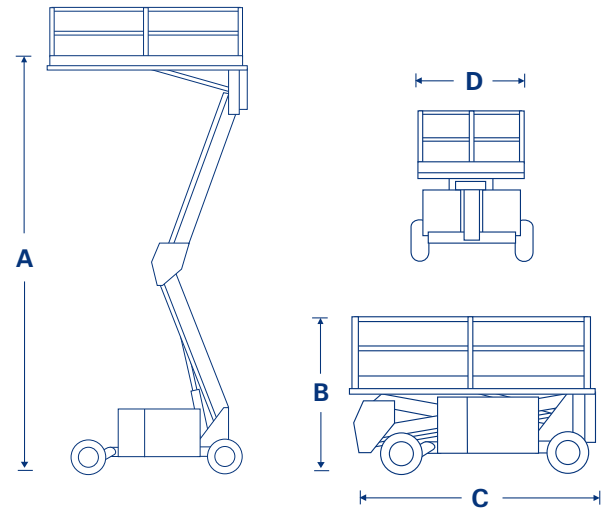
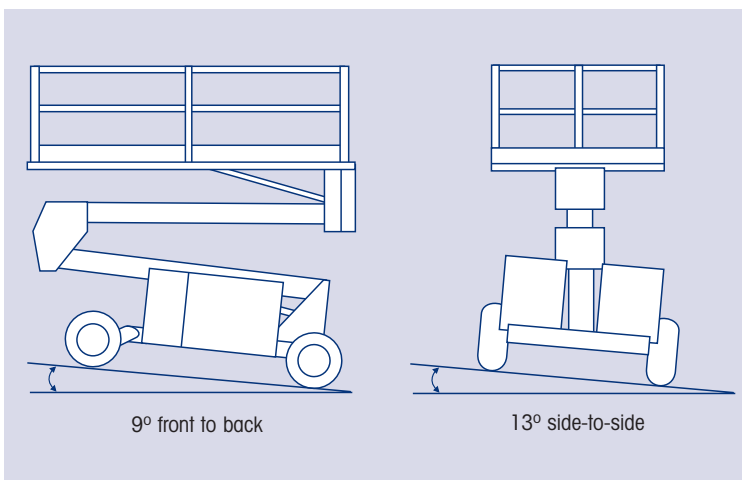

standard features

- Diesel power
- Decent alarm
- Hour meter
- Speed level - automatic powered platform levelling
- Oscillating front axle
- Poly-filled high grip tyres
- High grip open tread deck
- Dual multi-disc brakes
- One-hand, proportional controls
- Wired for AC outlet on platform
- Fold-down guardrails
- CE approved

options

- Special paint colours
- All motion alarm
- Flashing amber beacon and horn
- Diesel exhaust scrubber
- Environmental green oil

UpRight
POWERED ACCESS

Vigo Centre, Birtley Road,
Washington, Tyne & Wear,
NE38 9DA, U.K.

t: +44 (0) 845 1550 057
e: sales@upright.com

www.upright.com