

Genie®



Operator's Manual

with Maintenance Information

First Edition
Sixth Printing
Part No. 82800

Z™-135/70
from 101 to 778

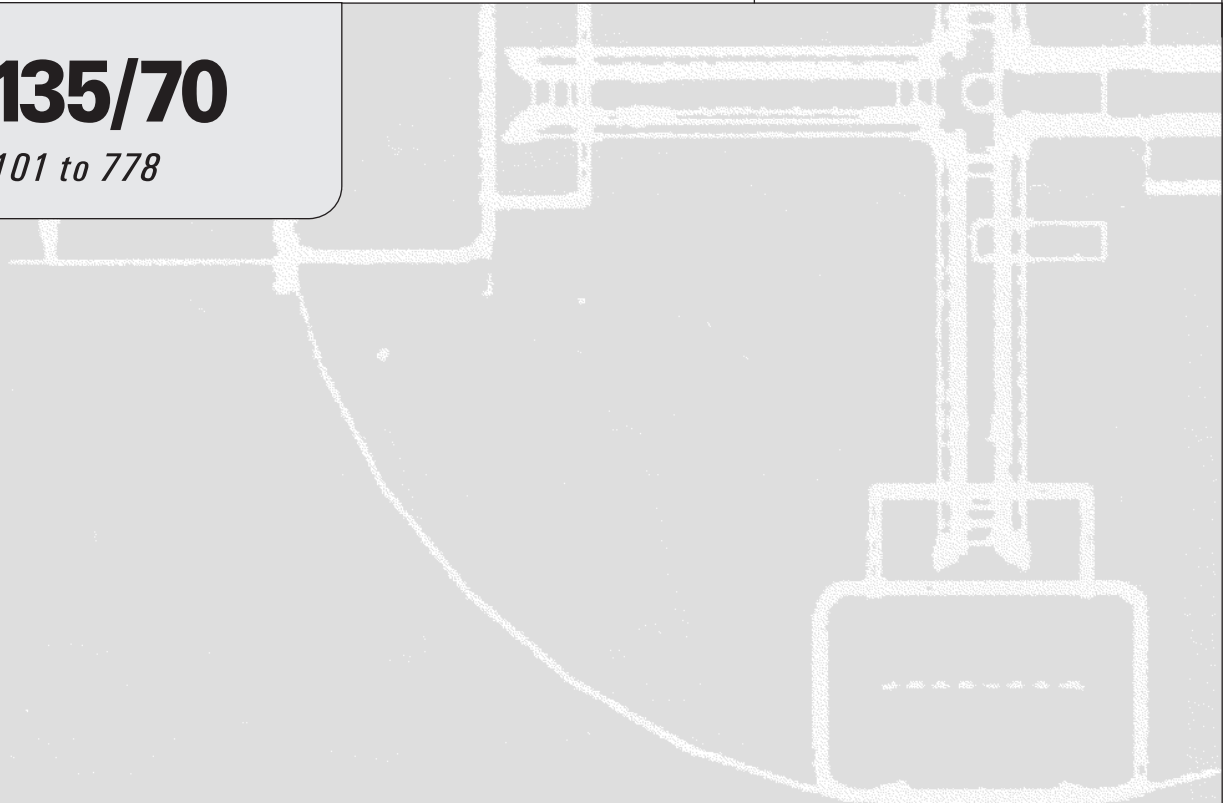

Important

Read, understand and obey these safety rules and operating instructions before operating this machine. Only trained and authorized personnel shall be permitted to operate this machine. This manual should be considered a permanent part of your machine and should remain with the machine at all times. If you have any questions, call Genie.

Contents

	Page
Safety Rules	1
Controls	8
Legend	16
Pre-operation Inspection	17
Maintenance	19
Function Tests	22
Workplace Inspection	30
Operating Instructions	31
Transport and Lifting Instructions	39
Decals	42
Specifications	46

Contact us:

Internet: <http://www.genielift.com>
 e-mail: awp.techpub@terex.com

Copyright © 2005 by Terex Corporation

First Edition: Sixth Printing, September 2015

"Genie" and "Z" are registered trademarks of Terex South Dakota in the U.S.A. and many other countries.

These machines comply with ANSI/SIA 92.5-1992.

 Printed on recycled paper

Printed in U.S.A.

Safety Rules



Danger

Failure to obey the instructions and safety rules in this manual will result in death or serious injury.

Do Not Operate Unless:

- You learn and practice the principles of safe machine operation contained in this operator's manual.

1 Avoid hazardous situations.

Know and understand the safety rules before going on to the next section.

- 2 Always perform a pre-operation inspection.
- 3 Always perform function tests prior to use.
- 4 Inspect the workplace.
- 5 Only use the machine as it was intended.

- You read, understand and obey the manufacturer's instructions and safety rules—safety and operator's manuals and machine decals.
- You read, understand and obey employer's safety rules and worksite regulations.
- You read, understand and obey all applicable governmental regulations.
- You are properly trained to safely operate the machine.

SAFETY RULES

Electrocution Hazards

This machine is not electrically insulated and will not provide protection from contact with or proximity to electrical current.

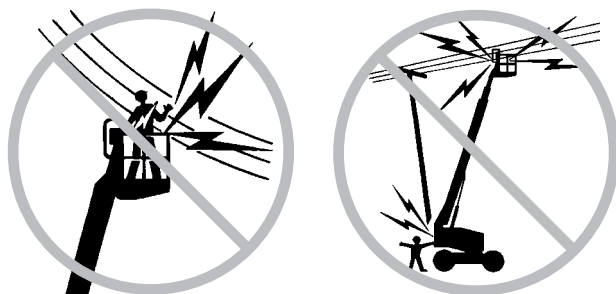

Maintain safe distances from electrical power lines and apparatus in accordance with applicable governmental regulations and the following chart.

Voltage Phase to Phase	Minimum Safe Approach Distance	
	Feet	Meters
0 to 300V	Avoid Contact	
300V to 50KV	10	3.05
50KV to 200KV	15	4.60
200KV to 350KV	20	6.10
350KV to 500KV	25	7.62
500KV to 750KV	35	10.67
750KV to 1000KV	45	13.72

Allow for platform movement, electrical line sway or sag and beware of strong or gusty winds.

Keep away from the machine if it contacts energized power lines. Personnel on the ground or in the platform must not touch or operate the machine until energized power lines are shut off.

Do not use the machine as a ground for welding unless the machine is equipped with the weld line to platform option and it is properly connected.

Before performing service on this machine, disconnect the batteries under both turntable covers.

Tip-over Hazards

Occupants, equipment and materials shall not exceed the maximum platform capacity.

Maximum platform capacity	600 lbs	272 kg
Maximum occupants	2	

The weight of options and accessories, such as pipe cradles, panel cradles and welders, will reduce the rated platform capacity and must be subtracted from the platform capacity. See the decals with the options and accessories.

If using accessories, read, understand and obey the decals, manuals and instructions with the accessory.

Do not raise or extend the boom unless the machine is on a firm, level surface.



Do not depend on the tilt alarm as a level indicator. The tilt alarm sounds in the platform only when the machine is on a severe slope.

SAFETY RULES

If the tilt alarm sounds:

Do not extend, rotate or raise the boom above horizontal. Move the machine to a firm, level surface before raising the platform. If the tilt alarm sounds when the platform is raised, use extreme caution to retract the boom and lower the platform. Do not rotate the boom while lowering. Move the machine to a firm, level surface before raising the platform.

Do not use the platform controls to free a platform that is caught, snagged or otherwise prevented from normal motion by an adjacent structure. All personnel must be removed from the platform before attempting to free the platform using the ground controls.

Do not raise the boom when wind speeds may exceed 28 mph / 12.5 m/s. If wind speeds exceed 28 mph / 12.5 m/s when the boom is raised, lower the boom and do not continue to operate the machine.

Do not operate the machine in strong or gusty winds. Do not increase the surface area of the platform or the load. Increasing the area exposed to the wind will decrease machine stability.

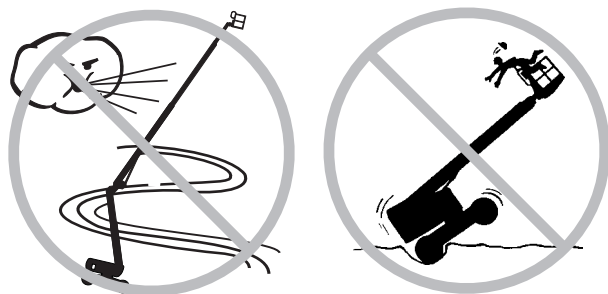

Use extreme care and slow speeds while driving the machine in the stowed position across uneven terrain, debris, unstable or slippery surfaces and near holes and drop-offs.

The recovery mode should be used by trained and authorized personnel only.

Do not drive the machine on or near uneven terrain, unstable surfaces or other hazardous conditions with the boom raised or extended.

Do not drive the machine on a slope that exceeds the maximum uphill, downhill or side slope rating of the machine. Slope rating applies only to machines in the stowed position.

Maximum slope rating, stowed position

Counterweight uphill	45% (24°)
Counterweight downhill	30% (17°)
Side slope	25% (14°)

Note: Slope rating is subject to ground conditions and adequate traction.

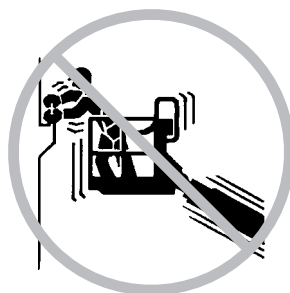

Maximum allowable side force - ANSI and CSA
150 lbs / 667 N

Maximum allowable manual force - CE and Australia
90 lbs / 400 N

Do not push off or pull toward any object outside of the platform.

Do not alter or disable machine components that in any way affect safety and stability.

Do not replace items critical to machine stability with items of different weight or specification.

SAFETY RULES

Do not modify or alter an aerial work platform without prior written permission from the manufacturer. Mounting attachments for holding tools or other materials onto the platform, toeboards or guard rail system can increase the weight in the platform and the surface area of the platform or the load.

Do not use air-filled tires. This machine is equipped with foam-filled tires. Wheel weight is critical to stability.

Do not replace factory-installed tires with tires of different specification or ply rating.

Do not place or attach overhanging loads to any part of this machine.

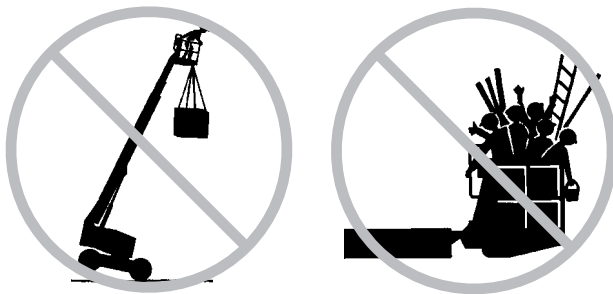

Do not place ladders or scaffolds in the platform or against any part of this machine.

Do not transport tools and materials unless they are evenly distributed and can be safely handled by person(s) in the platform.

Do not use the machine on a moving or mobile surface or vehicle.

Be sure all tires are in good condition and lug nuts are properly tightened.

Fall Hazards

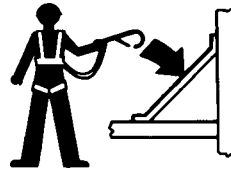

Occupants must wear a safety belt or harness in accordance with governmental regulations. Attach the lanyard to the anchorage point provided in the platform.

Do not sit, stand or climb on the platform guard rails. Maintain a firm footing on the platform floor at all times.



Do not climb down from the platform when raised.

Keep the platform floor clear of debris.

Lower the platform entry mid-rail or close the entry gate before operating.

SAFETY RULES

Collision Hazards



Be aware of limited sight distance and blind spots when driving or operating.

Be aware of boom position and tailswing when rotating the turntable.

Be aware of machine length when operating. The machine is 42 ft 5 inches / 12.9 m long.

Operators must comply with employer, job site and governmental rules regarding the use of personal protective equipment.

Check the work area for overhead obstructions or other possible hazards.



Be aware of crushing hazards when grasping the platform guard rail.

Observe and use the circle and square markings and the color-coded direction arrows on the platform controls and drive chassis for drive and steer functions.

Do not lower the boom unless the area below is clear of personnel and obstructions.



Limit travel speed according to the condition of the ground surface, congestion, slope, location of personnel, and any other factors which may cause collision.

Do not operate a boom in the path of any crane unless the controls of the crane have been locked out and/or precautions have been taken to prevent any potential collision.

No stunt driving or horseplay while operating a machine.

Component Damage Hazards

Do not use any battery or charger greater than 12V DC to jump-start the engine.

Do not use the machine as a ground for welding unless the machine is equipped with the weld line to platform option and it is properly connected.

SAFETY RULES

Explosion and Fire Hazards

Do not start the engine if you smell or detect liquid petroleum gas (LPG), gasoline, diesel fuel or other explosive substances.

Do not refuel the machine with the engine running.

Refuel the machine and charge the battery only in an open, well-ventilated area away from sparks, flames and lighted tobacco.

Do not operate the machine in hazardous locations or locations where potentially flammable or explosive gases or particles may be present.

Do not spray ether into engines equipped with glow plugs.

Damaged Machine Hazards

Do not use a damaged or malfunctioning machine.

Conduct a thorough pre-operation inspection of the machine and test all functions before each work shift. Immediately tag and remove from service a damaged or malfunctioning machine.

Be sure all maintenance has been performed as specified in this manual and the appropriate service manual.

Be sure all decals are in place and legible.

Be sure that the operator's, safety and responsibilities manuals are complete, legible and in the storage container located in the platform.

Bodily Injury Hazard

Do not operate the machine with a hydraulic oil or air leak. An air leak or hydraulic leak can penetrate and/or burn skin.

Always operate the machine in a well-ventilated area to avoid carbon monoxide poisoning.

Improper contact with components under any cover will cause serious injury. Only trained maintenance personnel should access compartments. Access by the operator is only advised when performing the pre-operation inspection. All compartments must remain closed and secured during operation.

Weld Line to Platform Safety (if equipped)

Read, understand and obey all warnings and instructions provided with the welding power unit.

Do not connect weld leads or cables unless the welding power unit is turned off at the platform controls.

Do not operate unless the weld cables are properly connected.

Connect the leads to the twist-lock connectors at the turntable and platform.

SAFETY RULES

Battery Safety

Burn Hazards

Batteries contain acid. Always wear protective clothing and eye wear when working with batteries.

Avoid spilling or contacting battery acid. Neutralize battery acid spills with baking soda and water.

Explosion Hazard

Keep sparks, flames and lighted tobacco away from batteries. Batteries emit explosive gas.

Electrocution Hazard

Avoid contact with electrical terminals.

Decal Legend

Genie product decals use symbols, color coding and signal words to identify the following:



Safety alert symbol—used to alert personnel to potential personal injury hazards. Obey all safety messages that follow this symbol to avoid possible injury or death.



Red—used to indicate the presence of an imminently hazardous situation which, if not avoided, will result in death or serious injury.



Orange—used to indicate the presence of a potentially hazardous situation which, if not avoided, could result in death or serious injury.



Yellow with safety alert symbol—used to indicate the presence of a potentially hazardous situation which, if not avoided, may cause minor or moderate injury.



Yellow without safety alert symbol—used to indicate the presence of a potentially hazardous situation which, if not avoided, may result in property damage.



Green—used to indicate operation or maintenance information.

Controls

Z-135 machines will have one of these two styles of platform control panel. The descriptions in this section and the instructions in the Function Test and Operating Instructions sections apply to both panels, unless specifically noted.

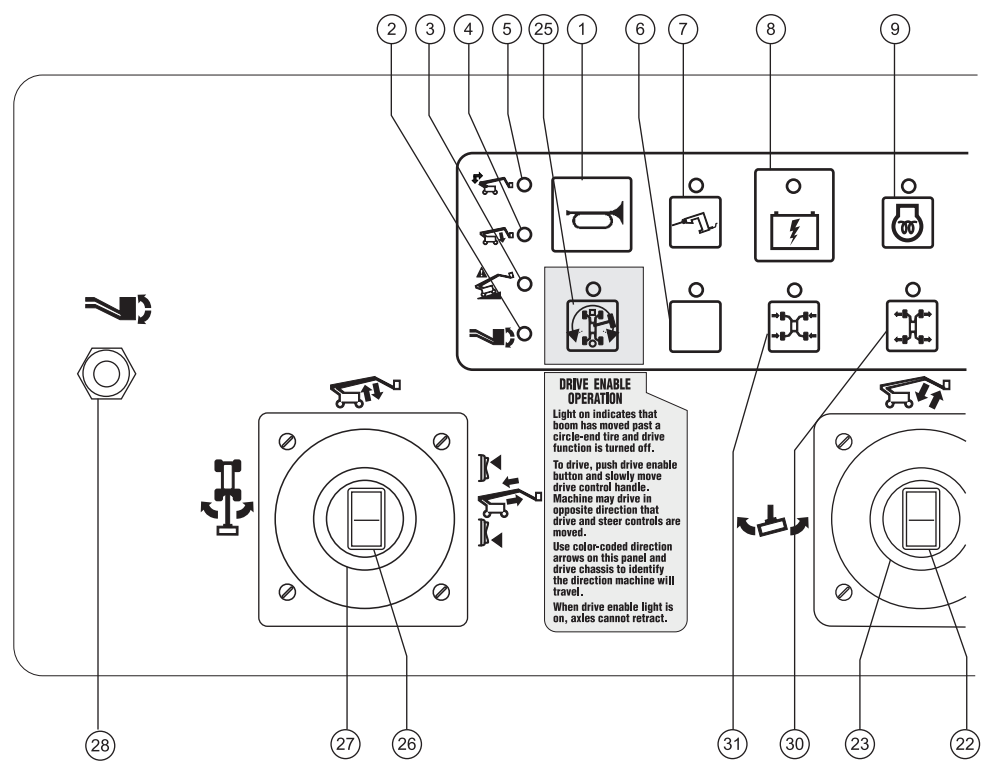
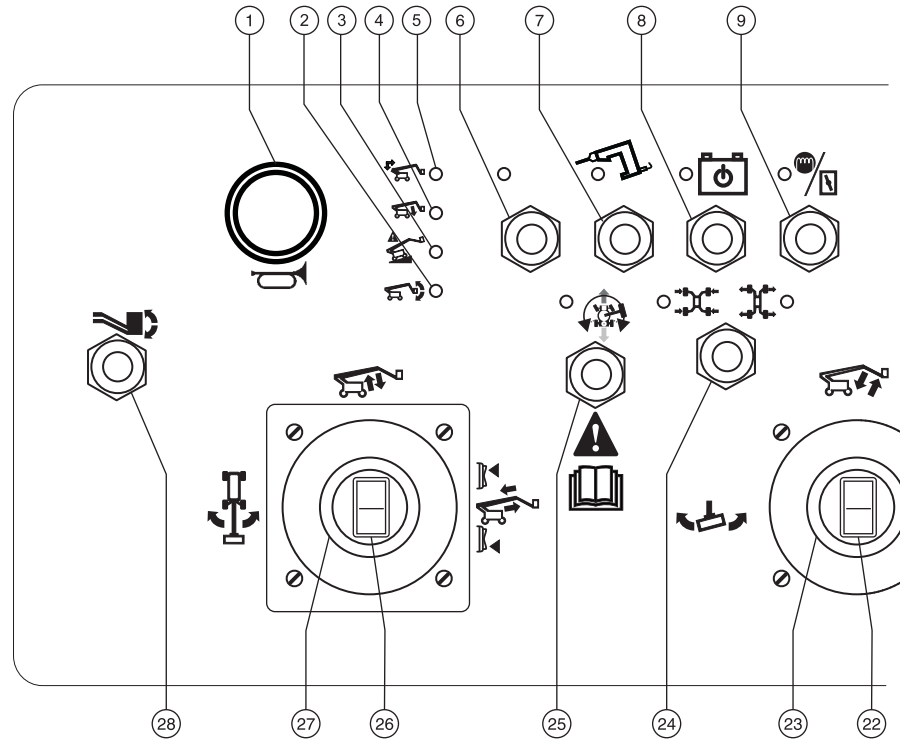

CONTROLS

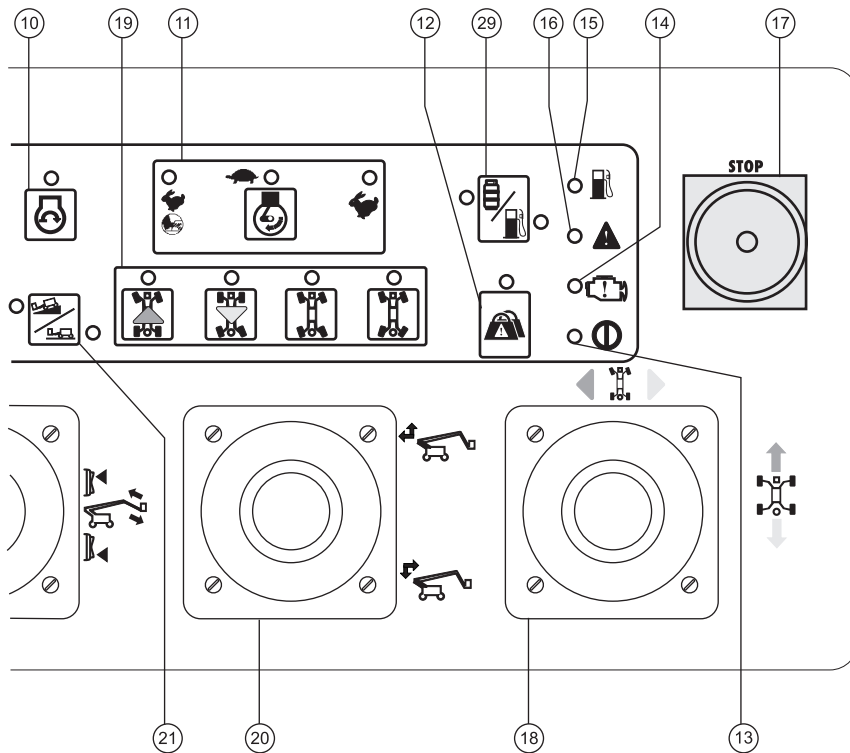
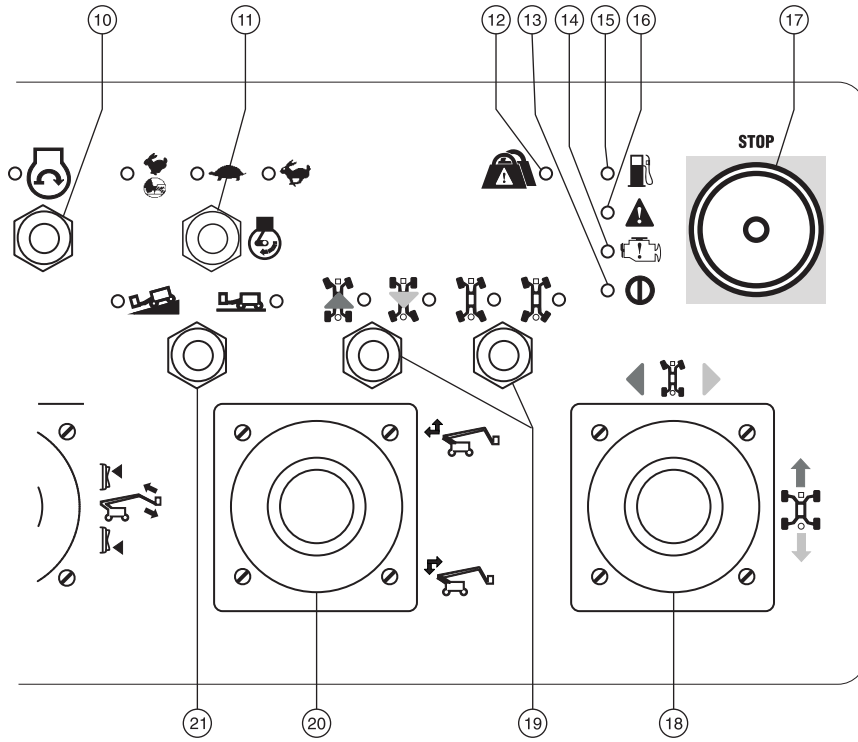

CONTROLS

Platform Control Panel

- 1 Horn button
Press the button and the horn will sound.
Release the button and the horn will stop.
- 2 Platform not level indicator light
Level the platform until the light is off. The switch will only work in the direction that will level the platform.
- 3 Machine on incline indicator light
Light on indicates all functions have stopped. See the instructions in the Operating Instructions section.
- 4 Lower primary boom indicator light
Lower the primary boom until the light is off.
- 5 Lower / retract secondary boom indicator light
Lower/retract the secondary boom until the light is off.
- 6 Used for optional equipment
- 7 Generator control with indicator light (if equipped)
Move the switch or push the button to turn the generator on. Move the switch again or release the button to turn the generator off.
- 8 Emergency/Auxiliary power control with indicator light
Use emergency/auxiliary power if the primary power source (engine) fails.

Move and hold the switch, or push and hold the button. Activate the desired function. The indicator light will be on when emergency/auxiliary power is being used.
- 9 Glow plug control with indicator light
Move the switch or push the button to activate the glow plugs.
- 10 Engine start control with indicator light
Move the switch or push the button and the engine will start. The indicator light will be on when the switch is moved or the button is pushed.
- 11 Engine idle control with indicator light
Move the switch or push the button to select engine idle setting. The indicator light next to the current engine idle setting will be on.
- 12 Platform overload indicator light (if equipped)
Light flashing indicates the platform is overloaded and no functions will operate. Remove weight from the platform until the light goes off.
- 13 Power indicator light
Light on indicates the machine is on.
- 14 Check engine indicator light
Light on indicates an engine fault.
- 15 Low fuel indicator light
Light on indicates the machine is low on fuel.
- 16 Fault indicator light
Light on indicates a system fault.
- 17 Red Emergency Stop button
Push in the red Emergency Stop button to the off position to stop all functions and turn the engine off. Pull out the red Emergency Stop button to the on position to operate the machine.

CONTROLS

- 18 Dual axis proportional control handle for drive and steer functions OR Proportional control handle for drive function and thumb rocker for steer function.

Move the control handle in the direction indicated by the blue arrow on the control panel and the machine will drive forward. Move the control handle in the direction indicated by the yellow arrow and the machine will drive backwards. Move the control handle in the direction indicated by the blue triangle and the machine will steer to the left. Move the control handle in the direction indicated by the yellow triangle and the machine will steer to the right.

OR

Move the control handle in the direction indicated by the blue arrow on the control panel and the machine will drive forward. Move the control handle in the direction indicated by the yellow arrow and the machine will drive backwards. Press the left side of the thumb rocker and the machine will steer to the left. Press the right side of the thumb rocker and the machine will steer to the right.

- 19 Steer mode control with indicator lights

Move the switch or push the button to choose steer mode.

The indicator light next to the current steer mode will be on.

- 20 Single axis proportional control handle for secondary boom up/extend and down/retract function

Move the control handle up and the secondary boom will raise and then extend. Move the control handle down and the secondary boom will retract and then lower.

- 21 Drive control with indicator lights

Move the switch or push the button to choose the drive setting. The indicator light next to the current setting will be on.

- 22 Thumb rocker for jib boom extend/retract function

Push the top of the rocker switch and the jib boom will retract. Push the bottom of the rocker switch and the jib boom will extend.

- 23 Dual axis proportional control handle for jib boom up/down and platform rotate left/right functions

Move the control handle up and the jib boom will raise. Move the control handle down and the jib boom will lower. Move the control handle to the left and the platform will rotate to the left. Move the control handle to the right and the platform will rotate to the right.

- 24 Axle extend/retract switch with indicator lights

Move the axle select switch to choose an axle setting. The indicator light will flash while the axles are extending and stay on when the axles are fully extended. The indicator light will flash while the axles are retracting and stay on when the axles are fully retracted.

- 25 Drive enable control with indicator light

Light on indicates that the primary boom has moved past either circle-end wheel and the drive function is turned off. To drive, move the drive enable switch or push the drive enable button and slowly move the drive/steer control handle off center.

CONTROLS

- 26 Thumb rocker switch for primary boom extend/retract function

Push the top of the rocker switch and primary boom will retract. Push the bottom of the rocker switch and the primary boom will extend.

- 27 Dual axis proportional control handle for primary boom up/down and turntable rotate left/right functions

Move the control handle up and the primary boom will raise. Move the control handle down and the primary boom will lower. Move the control handle to the left and the turntable will rotate to the left. Move the control handle to the right and the turntable will rotate to the right.

- 28 Platform level switch

Move the switch up and the level of the platform will raise. Move the switch down and the level of the platform will lower.

- 29 Not used

- 30 Axle extend button with indicator light

Push the axle extend button to extend the axles. The indicator light will flash while the axles are extending and stay on when the axles are fully extended.

- 31 Axle retract button with indicator light

Push the axle retract button to retract the axles. The indicator light will flash while the axles are retracting and stay on when the axles are fully retracted.

CONTROLS

Z-135 machines will have one of these two styles of ground control panel. The descriptions in this section and the instructions in the Function Test and Operating Instructions sections apply to both panels, unless specifically noted.

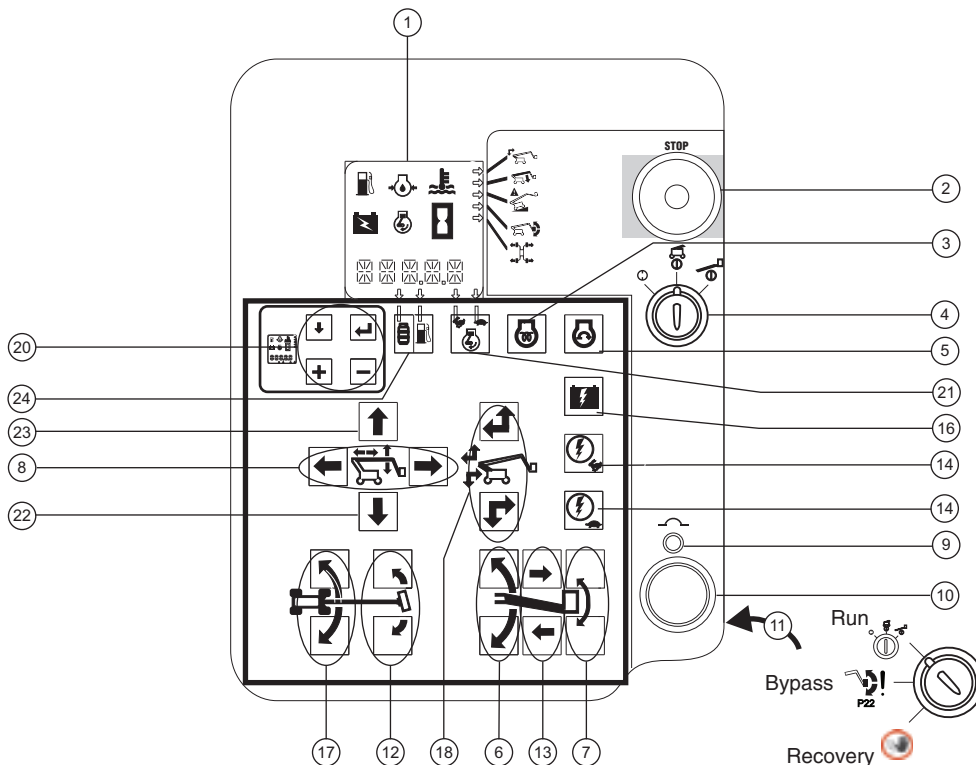
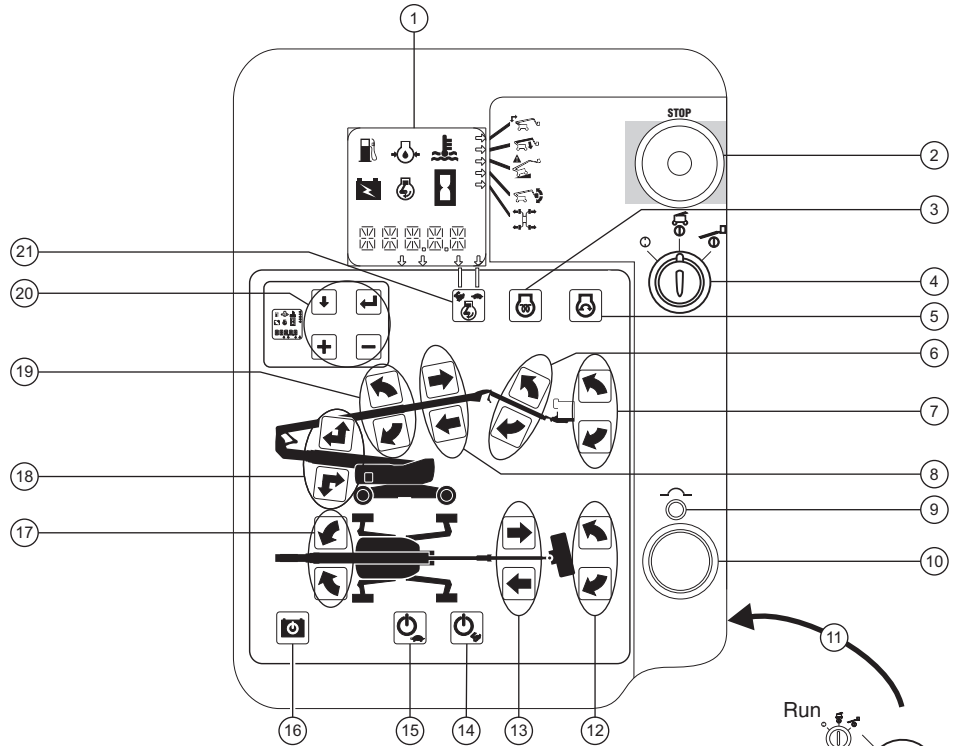

CONTROLS

Ground Control Panel

1 LCD readout screen



- a low fuel indicator
- b engine oil pressure indicator
- c water temperature indicator
- d auxiliary power indicator
- e high engine rpm indicator
- f hour meter

2 Red Emergency Stop button

Push in red Emergency Stop button to the off position to stop all functions and turn the engine off. Pull out the red Emergency Stop button to the on position to operate the machine.

3 Glow plug button

Push the glow plug button and hold for 3 to 5 seconds.

4 Key switch for off/ground/platform selection

Turn the key switch to the off position and the machine will be off. Turn the key switch to the ground position and the ground controls will operate. Turn the key switch to the platform position and the platform controls will operate.

5 Engine start button

Push the engine start button and the engine will start.

6 Jib boom up/down buttons

Push the jib boom up button and the jib boom will raise. Push the jib boom down button and the jib boom will lower.

7 Platform level up/down buttons

Push the platform level up button and the level of the platform will raise. Push the platform level down button and the level of the platform will lower.

8 Primary boom extend/retract buttons

Push the primary boom extend button and the primary boom will extend. Push the primary boom retract button and the primary boom will retract.

9 20A circuit breaker for system circuit

10 Alarm

11 Bypass/recovery key switch

Bypass key position to be used to level the platform if ground control display shows platform out of level (P22) and platform level controls do not work. Refer to the operating instructions.

Recovery key position should be used only by trained and authorized personnel.

12 Platform rotate left/right buttons

Push the platform rotate left button and the platform will rotate to the left. Push the platform rotate right button and the platform will rotate to the right.

13 Jib boom extend/retract buttons

Push the jib boom extend button and the jib boom will extend. Push the jib boom retract button and the jib boom will retract.

14 High speed function enable button

Push the high speed function enable switch to enable the functions on the ground control panel to operate at high speed.

CONTROLS

15 Low speed function enable button

Push the low speed function enable switch to enable the functions on the ground control panel to operate at low speed.

16 Emergency/Auxiliary power button

Use emergency/auxiliary power if the primary power source (engine) fails. Simultaneously push the emergency/auxiliary power button and activate the desired function.

17 Turntable rotate left/right buttons

Push the turntable rotate left button and the turntable will rotate to the left. Push the turntable rotate right button and the turntable will rotate to the right.

18 Secondary boom up/extend and down/retract buttons

Push the secondary boom up/extend button and the secondary boom will raise and then extend. Push the secondary boom down/retract button and the secondary boom will retract and then lower.

19 Primary boom up/down buttons

Push the primary boom up button and the primary boom will raise. Push the primary boom down button and the primary boom will lower.

20 LCD screen control buttons

21 Engine speed select button

Push the engine speed select button to select the engine speed. When the arrow above the rabbit is lit, the engine is in high idle speed. When the arrow above the turtle is lit, the engine is in low idle speed.

22 Primary boom down button

Push the primary boom down button and the primary boom will lower.

23 Primary boom up button

Push the primary boom up button and the primary boom will raise.

24 Not used

Legend

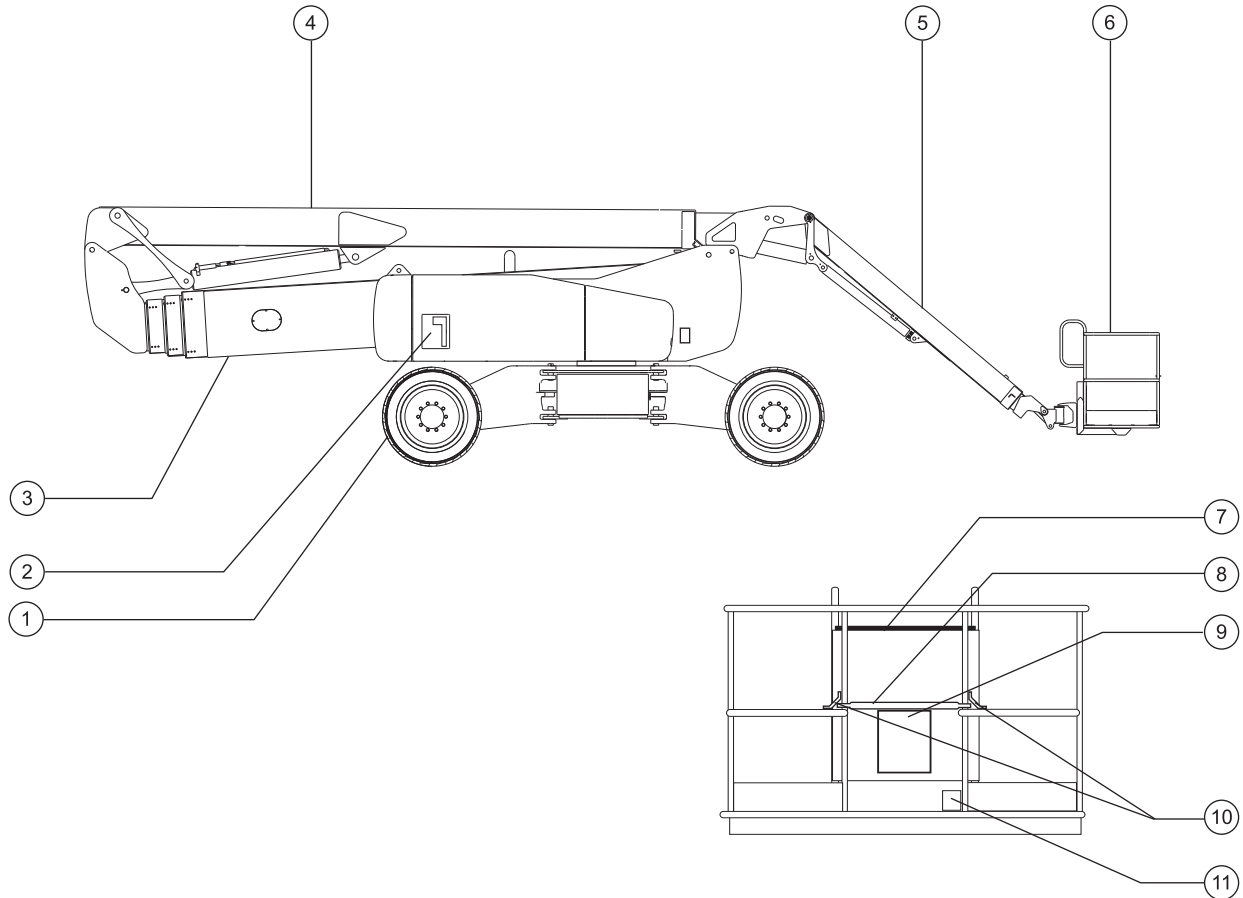

- | | |
|---------------------|----------------------------|
| 1 Square-end tire | 8 Sliding mid-rail |
| 2 Ground controls | 9 Manual storage container |
| 3 Secondary boom | 10 Lanyard anchorage point |
| 4 Primary boom | 11 Foot switch |
| 5 Jib boom | |
| 6 Platform | |
| 7 Platform controls | |

Pre-operation Inspection



Do Not Operate Unless:

- You learn and practice the principles of safe machine operation contained in this operator's manual.

- 1 Avoid hazardous situations.

- 2 Always perform a pre-operation inspection.**

Know and understand the pre-operation inspection before going on to the next section.

- 3 Always perform function tests prior to use.
- 4 Inspect the workplace.
- 5 Only use the machine as it was intended.

Fundamentals

It is the responsibility of the operator to perform a pre-operation inspection and routine maintenance.

The pre-operation inspection is a visual inspection performed by the operator prior to each work shift. The inspection is designed to discover if anything is apparently wrong with a machine before the operator performs the function tests.

The pre-operation inspection also serves to determine if routine maintenance procedures are required. Only routine maintenance items specified in this manual may be performed by the operator.

Refer to the list on the next page and check each of the items.

If damage or any unauthorized variation from factory delivered condition is discovered, the machine must be tagged and removed from service.

Repairs to the machine may only be made by a qualified service technician, according to the manufacturer's specifications. After repairs are completed, the operator must perform a pre-operation inspection again before going on to the function tests.

Scheduled maintenance inspections shall be performed by qualified service technicians, according to the manufacturer's specifications and the requirements listed in the responsibilities manual.

PRE-OPERATION INSPECTION

Pre-operation Inspection

- Be sure that the operator's, safety and responsibilities manuals are complete, legible and in the storage container located in the platform.
- Be sure that all decals are legible and in place. See Decals section.
- Check for engine oil leaks and proper oil level. Add oil if needed. See Maintenance section.
- Check for hydraulic oil leaks and proper oil level. Add oil if needed. See Maintenance section.
- Check for engine coolant leaks and proper level of coolant. Add coolant if needed. See Maintenance section.
- Check for battery fluid leaks and proper fluid level. Add distilled water if needed. See Maintenance section.

Check the following components or areas for damage, improperly installed or missing parts and unauthorized modifications:

- Electrical components, wiring and electrical cables
- Hydraulic hoses, fittings, cylinders and manifolds
- Fuel and hydraulic tanks
- Drive and turntable motors and drive hubs
- Boom wear pads
- Tires and wheels
- Engine and related components

- Limit switches
- Rotation sensors
- Steer and axle sensors
- Alarms and beacons (if equipped)
- Pins, nuts, bolts and other fasteners
- Platform entry mid-rail or gate

Check entire machine for:

- Cracks in welds or structural components
- Dents or damage to machine
- Excessive rust, corrosion or oxidation
- Be sure that all structural and other critical components are present and all associated fasteners and pins are in place and properly tightened.
- After you complete your inspection, be sure that all compartment covers are in place and latched.

Maintenance



Observe and Obey:

- ☑ Only routine maintenance items specified in this manual shall be performed by the operator.
- ☑ Scheduled maintenance inspections shall be completed by qualified service technicians, according to the manufacturer's specifications and the requirements specified in the responsibilities manual.

Maintenance Symbols Legend

NOTICE The following symbols have been used in this manual to help communicate the intent of the instructions. When one or more of the symbols appear at the beginning of a maintenance procedure, it conveys the meaning below.



Indicates that tools will be required to perform this procedure.



Indicates that new parts will be required to perform this procedure.



Indicates that a cold engine is required before performing this procedure.

Check the Engine Oil Level



Maintaining the proper engine oil level is essential to good engine performance and service life. Operating the machine with an improper oil level can damage engine components.

NOTICE Check the oil level with the engine off.

- 1 Check the engine oil dipstick. Add oil as needed.

Perkins 1104C-44 Engine

Oil type	15W-40
----------	--------

Oil type - cold conditions	10W-30
----------------------------	--------

Deutz BF4L2011 Engine

Oil type	15W-40
----------	--------

Oil type - cold conditions	5W-30
----------------------------	-------

Cummins B4.5C80 Engine

Oil type	15W-40
----------	--------

Oil type - cold conditions	10W-30
----------------------------	--------

MAINTENANCE

Check the Hydraulic Oil Level



Maintaining the hydraulic oil at the proper level is essential to machine operation. Improper hydraulic oil levels can damage hydraulic components. Daily checks allow the inspector to identify changes in the oil level that might indicate the presence of hydraulic system problems.

- 1 Be sure that the engine is off and the boom is in the stowed position.
 - 2 Visually inspect the sight gauge located on the side of the hydraulic oil tank.
- ⦿ **Result:** The hydraulic oil level should be between the two marks on the decal next to the sight gauge. Add oil as needed.

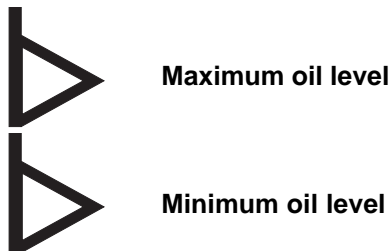
**Hydraulic oil specifications**

Hydraulic oil type	Chevron Rykon® Premium MV equivalent
--------------------	-----------------------------------------

Check the Batteries



Proper battery condition is essential to good engine performance and operational safety. Improper fluid levels or damaged cables and connections can result in engine component damage and hazardous conditions.

⚠ WARNING Electrocutation hazard. Contact with hot or live circuits may result in death or serious injury. Remove all rings, watches and other jewelry.

⚠ WARNING Bodily injury hazard. Batteries contain acid. Avoid spilling or contacting battery acid. Neutralize battery acid spills with baking soda and water.

- 1 Put on protective clothing and eye wear.
- 2 Be sure that the battery cable connections are tight and free of corrosion.
- 3 Be sure that the battery hold-down bar is in place and secure.
- 4 Remove the battery vent caps.
- 5 Check the battery acid level. If needed, replenish with distilled water to the bottom of the battery fill tube. Do not overfill.
- 6 Install the vent caps.

NOTICE Adding terminal protectors and a corrosion preventative sealant will help eliminate corrosion on the battery terminals and cables.

MAINTENANCE

Check the Engine Coolant Level - Liquid Cooled Models



Maintaining the engine coolant at the proper level is essential to engine service life. An improper coolant level will affect the engine's cooling capability and damage engine components. Daily checks will allow the inspector to identify changes in coolant level that might indicate cooling system problems.

- 1 Check the fluid level in the coolant recovery tank. Add fluid as needed.

⦿ Result: The fluid level should be in the NORMAL range.

⚠ WARNING Bodily injury hazard. Fluids in the radiator are under pressure and extremely hot. Use caution when removing cap and adding fluids.

Scheduled Maintenance

Maintenance performed quarterly, annually and every two years must be completed by a person trained and qualified to perform maintenance on this machine according to the procedures found in the service manual for this machine.

Machines that have been out of service for more than three months must receive the quarterly inspection before they are put back into service.

Function Tests



Do Not Operate Unless:

- ☑ You learn and practice the principles of safe machine operation contained in this operator's manual.

1 Avoid hazardous situations.

2 Always perform a pre-operation inspection.

3 Always perform function tests prior to use.

Know and understand the function tests before going on to the next section.

4 Inspect the workplace.

5 Only use the machine as it was intended.

Fundamentals

The function tests are designed to discover any malfunctions before the machine is put into service. The operator must follow the step-by-step instructions to test all machine functions.

A malfunctioning machine must never be used. If malfunctions are discovered, the machine must be tagged and removed from service. Repairs to the machine may only be made by a qualified service technician, according to the manufacturer's specifications.

After repairs are completed, the operator must perform a pre-operation inspection and function tests again before putting the machine into service.

- 1 Select a test area that is firm, level and free of obstruction.

At the Ground Controls

- 2 Turn the key switch to ground control.

- 3 Pull out the red Emergency Stop button to the on position.

- ☉ Result: The LCD screen will come on and display no error messages. The beacon (if equipped) should flash.

Note: In cold climates, the LCD readout screen will need to warm up before the display appears.

- 4 Start the engine. See Operating Instructions section.

Test Emergency Stop

- 5 Push in the red Emergency Stop button to the off position.

- ☉ Result: The engine should turn off and no functions should operate.

- 6 Pull out the red Emergency Stop button to the on position and restart the engine.

Test the Extendable Axles

Note: Start this test with the axles retracted.

- 7 At the ground controls, push and hold a function enable/speed select button and push the primary boom up button.

- ☉ Result: The primary boom should not raise. On the LCD screen, the arrow next to the extend axle symbol will flash. The boom should not raise unless the axles are extended.

FUNCTION TESTS

- 8 Push and hold a function enable/speed select button and press the secondary boom raise/extend button.
 - ⦿ Result: The secondary boom should not raise. On the LCD screen, the arrow next to the extend axle symbol will flash. The secondary boom should not raise unless the axles are extended.
- 9 Push and hold a function enable/speed select button and press the primary boom extend button.
 - ⦿ Result: The primary boom should not extend. On the LCD screen, the arrow next to the extend axle symbol will flash. The primary boom should not extend unless the axles are extended.
- 10 Push and hold a function enable/speed select button and push the turntable rotate left button.
 - ⦿ Result: The turntable should rotate 15° and then stop. The turntable should not rotate more than 15° unless the axles are extended.
- 11 Push and hold a function enable/speed select button and push the turntable rotate right button.
 - ⦿ Result: The turntable should return to center, rotate 15° to the right and then stop. The turntable should not rotate more than 15° unless the axles are extended.
- 12 Turn the key switch to platform control. At the platform controls, press and hold the foot switch and move the drive control handle in the forward direction.
- 13 Activate the extend axle function.
 - ⦿ Result: The machine should drive and the axles should extend. The indicator light will flash while the axles are moving and stay on when the axles are fully extended.
- 14 Return to the ground controls. Turn the key switch to ground control.
- 15 Push and hold a function enable/speed select button and push the primary boom up button and then the primary boom down button.
 - ⦿ Result: The primary boom should raise and lower normally.
- 16 Push and hold a function enable/speed select button and push the secondary boom raise/extend button and then the secondary boom lower/retract button.
 - ⦿ Result: The secondary boom should raise and extend and retract and lower normally.
- 17 Push and hold a function enable/speed select button and push the primary boom extend button and then the primary boom retract button.
 - ⦿ Result: The primary boom should extend and retract normally.
- 18 Push and hold a function enable/speed select button and push the turntable rotate left button and then the turntable rotate right button.
 - ⦿ Result: The turntable should rotate normally.

FUNCTION TESTS

Test the Machine Functions

- 19 Do not press and hold a function enable/speed select button. Attempt to activate each boom and platform function button.
- ⦿ Result: No boom and platform functions should operate.
- 20 Press and hold a function enable /speed select button and activate each boom and platform function button.
- ⦿ Result: All boom and platform functions should operate through a full cycle. The descent alarm (if equipped) should sound while the boom is lowering.

Test Emergency/Auxiliary Controls

- 21 Push in the red Emergency Stop button to the off position to turn off the engine.
- 22 Pull out the red Emergency Stop button to the on position.
- 23 Simultaneously push and hold the emergency/auxiliary power button and push each boom function button.



Note: To conserve battery power, test each function through a partial cycle.



- ⦿ Result: All boom functions should operate.
- 24 Start the engine.

Test the Tilt Sensor

- 25 Push one of the LCD screen control buttons until TURNTABLE LEVEL SENSOR X-DIRECTION appears.
- ↓

↶
- ⦿ Result: The LCD screen should display the angle in degrees.
- 26 Push one of the LCD screen control buttons until TURNTABLE LEVEL SENSOR Y-DIRECTION appears.
- ⦿ Result: The LCD screen should display the angle in degrees.
- 27 Push one of the LCD screen control buttons until PLATFORM LEVEL SENSOR DEGREES appears.
- ⦿ Result: The LCD screen should display the angle in degrees.

FUNCTION TESTS

Test the Operating Envelope

- 28 Push one of the LCD screen control buttons shown until PRI BOOM ANGLE TO GRAVITY is displayed.



- 29 Raise the primary boom and observe the LCD screen.

- Result: The primary boom should raise and the LCD screen should display the primary boom angle in degrees.

- 30 Lower the primary boom.

- 31 Simultaneously push the 2 LCD screen control buttons shown to activate status mode.



- 32 Push one of the LCD screen control buttons shown until SEC BOOM ANGLE is displayed.



- 33 Push and hold the secondary boom up/extend button.

- Result: The secondary boom should raise and the LCD screen should display the secondary boom angle in degrees.

The secondary boom should raise and then extend. The secondary boom should not extend until it is fully raised.

- 34 Push and hold the secondary boom down/retract button.

- Result: The secondary boom should fully retract and then lower. The secondary boom should not lower unless it is fully retracted.

At the Platform Controls**Test Emergency Stop**

- 35 Turn the key switch to platform control.
- 36 Push in the platform red Emergency Stop button to the off position.

- Result: The engine should turn off and no functions should operate.

- 37 Pull out the red Emergency Stop button and restart the engine.

Test the Horn

- 38 Push the horn button.

- Result: The horn should sound.

Test the Tilt Sensor Alarm

- 39 Push a button or move a switch, such as the engine idle control.

- Result: The alarm should sound at the platform controls.

FUNCTION TESTS

Test the Foot Switch

- 40 Push in the platform red Emergency Stop button to the off position.
- 41 Pull out the red Emergency Stop button to the on position but do not start the engine.
- 42 Press down the foot switch and attempt to start the engine.
- ⦿ Result: The engine should not start.
- 43 Do not press down the foot switch and restart the engine.
- 44 Do not press down the foot switch and test each machine function.
- ⦿ Result: No machine functions should operate.

Test Machine Functions

- 45 Press down the foot switch.
- 46 Activate each machine function control handle, toggle switch or button.
- ⦿ Result: All functions should operate through a full cycle.

Test the Steering

- 47 Select square-end (blue arrow) steer. Push the square-end (blue arrow) steer button or move the steer mode switch.
- 48 Press down the foot switch.
- 49 Slowly move the drive/steer control handle in the direction indicated by the blue triangle on the control panel OR press the thumb rocker switch in the direction indicated by the blue triangle.
- ⦿ Result: The square-end wheels should turn in the direction that the blue triangles point on the drive chassis.
- 50 Slowly move the drive/steer control handle in the direction indicated by the yellow triangle on the control panel OR press the thumb rocker switch in the direction indicated by the yellow triangle.
- ⦿ Result: The square-end wheels should turn in the direction that the yellow triangles point on the drive chassis.
- 51 Select circle-end (yellow arrow) steer. Push the circle-end (yellow arrow) steer button or move the steer mode switch.
- 52 Press down the foot switch.
- 53 Slowly move the drive/steer control handle in the direction indicated by the yellow triangle on the control panel OR press the thumb rocker switch in the direction indicated by the yellow triangle.
- ⦿ Result: The circle-end wheels should turn in the direction that the blue triangles point on the drive chassis.



FUNCTION TESTS

54 Slowly move the drive/steer control handle in the direction indicated by the blue triangle on the control panel OR press the thumb rocker switch in the direction indicated by the blue triangle.

- ⦿ Result: The circle-end wheels should turn in the direction that the yellow triangles point on the drive chassis.

55 Select crab steer. Push the crab steer button or move the steer mode switch.



56 Press down the foot switch.

57 Slowly move the drive/steer control handle in the direction indicated by the blue triangle on the control panel OR press the thumb rocker switch in the direction indicated by the blue triangle.

- ⦿ Result: All wheels should turn in the direction that the blue triangles point on the drive chassis.

58 Slowly move the drive/steer control handle in the direction indicated by the yellow triangle on the control panel OR press the thumb rocker switch in the direction indicated by the yellow triangle.

- ⦿ Result: All wheels should turn in the direction that the yellow triangles point on the drive chassis.

59 Select coordinated steer. Push the coordinated steer button or move the steer mode switch.



60 Press down the foot switch.

61 Slowly move the drive/steer control handle in the direction indicated by the blue triangle on the control panel OR press the thumb rocker switch in the direction indicated by the blue triangle.

- ⦿ Result: The square-end wheels should turn in the direction that the blue triangles point on the drive chassis. The circle-end wheels should turn in the direction that the yellow triangles point on the drive chassis.

62 Slowly move the drive/steer control handle in the direction indicated by the yellow triangle on the control panel OR press the thumb rocker switch in the direction indicated by the yellow triangle.

- ⦿ Result: The square-end wheels should turn in the direction that the yellow triangles point on the drive chassis. The circle-end wheels should turn in the direction that the blue triangles point on the drive chassis.

FUNCTION TESTS

Test Drive and Braking

- 63 Press down the foot switch.
- 64 Slowly move the drive/steer control handle in the direction indicated by the blue arrow on the control panel until the machine begins to move, then return the handle to the center position.
- ⦿ Result: The machine should move in the direction that the blue arrow points on the drive chassis, then come to an abrupt stop.
- 65 Slowly move the drive/steer control handle in the direction indicated by the yellow arrow on the control panel until the machine begins to move, then return the handle to the center position.
- ⦿ Result: The machine should move in the direction that the yellow arrow points on the drive chassis, then come to an abrupt stop.

Note: The brakes must be able to hold the machine on any slope it is able to climb.

Test the Drive Enable System

- 66 Press down the foot switch and lower the booms to the stowed position.
- 67 Rotate the turntable until the primary boom moves past one of the circle-end tires.

- ⦿ Result: The drive enable indicator light should come on while the boom is anywhere in the range shown.



- 68 Move the drive/steer control handle off center.
- ⦿ Result: No drive function should operate.

- 69 Push the drive enable button or move the drive enable switch and slowly move the drive/steer control handle off center.

- ⦿ Result: The drive function should operate.

Note: When the drive enable system is in use, the machine may drive in the opposite direction that the drive and steer control handle is moved.

Use the color-coded direction arrows on the platform controls and the drive chassis to identify the direction of travel.

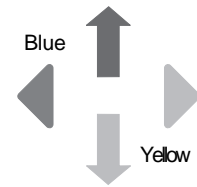

If the drive/steer control handle is not moved within two seconds of pushing the drive enable button, the drive function will not operate.

Test Limited Drive Speed

- 70 Press down the foot switch.
- 71 Raise the primary boom to 5° above horizontal.
- 72 Slowly move the drive control handle to the full drive position.
- ⦿ Result: The maximum achievable drive speed with the primary boom raised should not exceed 1 foot / 30 cm per second.

Note: The machine will travel 40 feet / 12 m in 40 seconds.

- 73 Lower the primary boom to the stowed position.
- 74 Extend the primary boom 4 feet / 1.2 m.
- 75 Slowly move the drive control handle to the full drive position.

- ⦿ Result: The maximum achievable drive speed with the primary boom extended should not exceed 1 foot / 30 cm per second.

Note: The machine will travel 40 feet / 12 m in 40 seconds.

FUNCTION TESTS

76 Retract the primary boom to the stowed position.

77 Raise the secondary boom to 5° above horizontal.

78 Slowly move the drive control handle to the full drive position.

- ⊙ Result: The maximum achievable drive speed with the secondary boom raised should not exceed 1 foot / 30 cm per second.

Note: The machine will travel 40 feet / 12 m in 40 seconds.

79 Lower the secondary boom to the stowed position.

80 Extend the jib boom 1 foot / 30 cm.

81 Slowly move the drive control handle to the full drive position.

- ⊙ Result: The maximum achievable drive speed with the jib boom extended should not exceed 1 foot / 30 cm per second.

If the drive speed with the primary or secondary boom raised or extended or the jib boom extended exceeds 1 foot / 30 cm per second, immediately tag and remove the machine from service.

82 Extend the primary boom 4 feet / 1.2 m.

83 Slowly move the drive control handle to the full drive position.

- ⊙ Result: The maximum achievable drive speed with the jib boom extended and the primary boom extended should not exceed 6 inches / 15 cm per second.

If the drive speed with the jib boom extended and the primary boom extended exceeds 6 inches / 15 cm per second, immediately tag and remove the machine from service.

84 Retract the primary boom and the jib boom.

Test Emergency/Auxiliary Controls

85 Push in the red Emergency Stop button to the off position to shut off the engine.

86 Pull out the red Emergency Stop button to the on position.

87 Press down the foot switch.

88 Activate the emergency/auxiliary controls. Move and hold the switch or push and hold the button. Activate each function control handle, switch or button.

Note: To conserve battery power, test each function through a partial cycle.

- ⊙ Result: All boom and steer functions should operate.

Test Aircraft Protection Package (if equipped)

Note: Two people may be required to perform this test.

89 Move the yellow bumper at the bottom of the platform 4 inches / 10 cm in any direction.

90 Activate each function control handle, toggle switch, rocker switch or button.

- ⊙ Result: No functions should operate.

91 Activate the function override function. Move the switch or push the button.

92 Activate each function control handle, toggle switch, rocker switch or button.

- ⊙ Result: All boom and steer functions should operate.

Workplace Inspection



Do Not Operate Unless:

- You learn and practice the principles of safe machine operation contained in this operator's manual.

- 1 Avoid hazardous situations.
- 2 Always perform a pre-operation inspection.
- 3 Always perform function tests prior to use.

4 Inspect the workplace.

Know and understand the workplace inspection before going on to the next section.

- 5 Only use the machine as it was intended.

Workplace Inspection

Be aware of and avoid the following hazardous situations:

- drop-offs or holes
- bumps, floor obstructions or debris
- sloped surfaces
- unstable or slippery surfaces
- overhead obstructions and high voltage conductors
- hazardous locations
- inadequate surface support to withstand all load forces imposed by the machine
- wind and weather conditions
- the presence of unauthorized personnel
- other possible unsafe conditions

Fundamentals

The workplace inspection helps the operator determine if the workplace is suitable for safe machine operation. It should be performed by the operator prior to moving the machine to the workplace.

It is the operator's responsibility to read and remember the workplace hazards, then watch for and avoid them while moving, setting up and operating the machine.

Operating Instructions



Do Not Operate Unless:

- You learn and practice the principles of safe machine operation contained in this operator's manual.
 - 1 Avoid hazardous situations.
 - 2 Always perform a pre-operation inspection.
 - 3 Always perform function tests prior to use.
 - 4 Inspect the workplace.
 - 5 Only use the machine as it was intended.**

Fundamentals

The Operating Instructions section provides instructions for each aspect of machine operation. It is the operator's responsibility to follow all the safety rules and instructions in the operator's, safety and responsibilities manuals.

Using the machine for anything other than lifting personnel, along with their tools and materials, to an aerial work site is unsafe and dangerous.

Only trained and authorized personnel should be permitted to operate a machine. If more than one operator is expected to use a machine at different times in the same work shift, they must all be qualified operators and are all expected to follow all safety rules and instructions in the operator's, safety and responsibilities manuals. That means every new operator should perform a pre-operation inspection, function tests, and a workplace inspection before using the machine.

OPERATING INSTRUCTIONS

Starting the Engine

- 1 At the ground controls, turn the key switch to the desired position.

Deutz models

- 2 Activate the glow plugs. Push the button or move the switch. The glow plugs will turn on for 30 seconds.
- 3 Start the engine. Press the button or move the switch.



The engine start button can be pressed at any time while the glow plugs are on.

Perkins and Cummins models

- 2 Activate the glow plugs for 3-5 seconds. Push and hold the button or move and hold the switch.
- 3 Start the engine. Press the button or move and hold the switch.

If the engine fails to start after 15 seconds of cranking, determine the cause and repair any malfunction. Wait 60 seconds before trying to start again.

In cold conditions, 20°F / -6°C and below, warm the engine for 5 minutes before operating to prevent hydraulic system damage.

In extreme cold conditions, 0°F / -18°C and below, machines should be equipped with optional cold start kits. Attempting to start the engine when temperatures are below 0°F / -18°C may require the use of a booster battery.

If the machine is stored for long periods of time in low temperatures (below 32°F / 0°C) with the secondary boom raised and extended, the engine may not start due to a system fault.

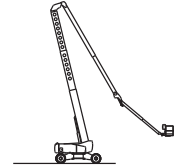

To remove the fault, hold the auxiliary power button and activate the secondary boom up function until the secondary boom begins extending.

Emergency Stop

Push in either the ground or platform red Emergency Stop button to the off position to stop all functions and turn the engine off.

Repair any function that operates when the red Emergency Stop button is pushed in to the off position.

Selecting and operating the ground controls will override the platform red Emergency Stop button.

Emergency/Auxiliary Power

Use emergency/auxiliary power if the primary power source (engine) fails.

- 1 Turn the key switch to ground or platform control.
- 2 Pull out the red Emergency Stop button to the on position.
- 3 Press down the foot switch when operating the emergency/auxiliary controls from the platform.
- 4 Move and hold the switch or push and hold the button. Activate the desired function. The indicator light will be on when emergency/auxiliary power is being used.



OPERATING INSTRUCTIONS

To Extend and Retract Axles

- 1 Turn the key switch to platform control.
- 2 At the platform controls, press down the foot switch and move the drive control handle in either direction. Activate the extend axle function or the retract axle function. Move the switch or push the button.



The indicator light will flash while the axles are moving and stay on when the axles are fully extended or retracted.

The axles can only be retracted if the primary and secondary booms are fully lowered and retracted and the platform is between the circle-end wheels.

Operation from Ground

- 1 Turn the key switch to ground control.
- 2 Pull out the red Emergency Stop button to the on position.
- 3 Start the engine.

To Position Platform

- 1 Push and hold a function enable/speed select button.



- 2 Push the appropriate function button according to the markings on the control panel.

Drive, steer and axle functions are not available from the ground controls.

Operation from Platform

- 1 Turn the key switch to platform control.
- 2 Pull out both ground and platform red Emergency Stop buttons to the on position.
- 3 Start the engine. Do not press down the foot switch when starting the engine.

To Position Platform

- 1 Press down the foot switch.
- 2 Slowly move the appropriate function control handle or toggle switch or press the appropriate button according to the markings on the control panel.

To Steer

- 1 Press down the foot switch.
- 2 Select the steer mode. Move the switch or push the button. The indicator light next to the current steer mode will be on.



- 3 Slowly move the drive/steer control handle in the direction indicated by the blue or yellow triangles OR press the thumb rocker switch located on top of the drive control handle.

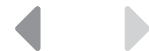

Use the color-coded direction arrows on the platform controls and the drive chassis to identify the direction the wheels will turn.

OPERATING INSTRUCTIONS

To Drive

- 1 Press down the foot switch.
- 2 Increase speed: Slowly move the drive/steer control handle in the direction indicated by the blue or yellow arrows.



Decrease speed: Slowly move the drive/steer control handle toward center.

Stop: Return the drive/steer control handle to center or release the foot switch.

Use the color-coded direction arrows on the platform controls and the drive chassis to identify the direction the machine will travel.

Machine travel speed is restricted when the boom is raised or extended.

Driving on a slope

Determine the uphill, downhill and side slope ratings for the machine and determine the slope grade.



Maximum slope rating, counterweight uphill (gradeability): 45% (24°)



Maximum slope rating, counterweight downhill: 30% (17°)



Maximum side slope rating: 25% (14°)

Note: Slope rating is subject to ground conditions and adequate traction. The term gradeability applies to the counterweight uphill configuration only.

Be sure the boom is below horizontal and the platform is between the circle-end wheels.

Select the machine on incline drive setting.

To determine the slope grade:

Measure the slope with a digital inclinometer OR use the following procedure.

You will need:

- carpenter's level
- straight piece of wood, at least 3 feet / 1 m long
- tape measure

Lay the piece of wood on the slope.

At the downhill end, lay the level on the top edge of the piece of wood and lift the end until the piece of wood is level.

While holding the piece of wood level, measure the vertical distance from the bottom of the piece of wood to the ground.

Divide the tape measure distance (rise) by the length of the piece of wood (run) and multiply by 100.

Example:



Piece of wood = 144 inches (3.6 m)

Run = 144 inches (3.6 m)

Rise = 12 inches (0.3 m)

$$12 \text{ in} \div 144 \text{ in} = 0.083 \times 100 = 8.3\% \text{ grade}$$

$$0.3 \text{ m} \div 3.6 \text{ m} = 0.083 \times 100 = 8.3\% \text{ grade}$$

If the slope exceeds the maximum uphill, downhill or side slope rating, then the machine must be winched or transported up or down the slope. See the Transport and Lifting section.

OPERATING INSTRUCTIONS

Drive Enable

Light on indicates that the primary boom has moved past either circle-end wheel and the drive function is turned off.

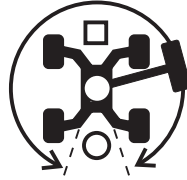

To drive, activate the drive enable function and slowly move the drive/steer control handle off center. Push the drive enable button or move the drive enable switch.

If the drive/steer control handle is not moved within two seconds of activating the drive enable function, the drive function will not operate. Release and activate the drive enable function again.

Be aware that the machine may move in the opposite direction that the drive and steer controls are moved.

Always use the color-coded direction arrows on the platform controls and the drive chassis to identify the direction the machine will travel.

When the drive enable light is on, the axles cannot retract.

Engine Idle Select (rpm)

Select the engine idle (rpm) setting. Move the switch or push the button. The indicator light next to the current setting will be on.



- Rabbit and foot switch symbol: foot switch activated high idle
- Turtle symbol: low idle
- Rabbit symbol: high idle

Check Engine Light



Light on and engine stopped: Tag the machine and remove from service.

Light on and engine still running: Contact service personnel within 24 hours.

OPERATING INSTRUCTIONS

Operating Envelope Indicator Lights

The operating envelope indicator lights will come on to notify the operator that a function has been interrupted and/or an action is required by the operator.

- 

Lower/Retract Secondary Boom indicator light flashing: Lower/retract the secondary boom until the indicator light is off.
- 

Lower Primary Boom indicator light flashing: Lower the primary boom until the indicator light is off.
- 

Machine Not Level indicator light flashing: The tilt alarm will be sounding when this light is flashing. Move the machine to a firm, level surface.
- 

Platform Not Level indicator light flashing: The tilt alarm will be sounding when this light is flashing. The Platform Level toggle switch will only work in the direction that will level the platform. Level the platform until the indicator light is off.

Platform Out of Level (P22 code)

Bypass key position to be used to level the platform if ground control display shows platform out of level (P22) and platform level controls do not work.

To operate:

- 1 Turn the engine off.
- 2 Turn the main key switch to ground control. Remove the key from the main key switch and insert the key into the bypass/recovery key switch.
- 3 Turn the bypass/recovery key switch to the bypass position.
- 4 Using auxiliary/emergency power, operate the platform level buttons to level the platform.
- 5 Turn the bypass/recovery key switch to the run position.
- 6 Remove the key from the bypass/recovery key switch and insert the key into the main key switch.
- 7 Push in and then pull out the red Emergency Stop button.
- 8 If the P22 code is still visible, tag and remove the machine from service until the fault has been corrected by a qualified service technician.



OPERATING INSTRUCTIONS

Platform Out of Level (Platform Level > 15 Degrees Fault)

If ground controls display shows PLATFORM LEVEL > 15 DEGREES FAULT and the platform level controls do not work, the machine will need to be recovered by trained and authorized personnel or a qualified service technician.

Generator (if equipped)

To operate the generator, press the generator button or move the generator switch. The indicator light will come on and the engine will continue to run.

Plug power tools into the power to platform GFCI outlet.

To turn off the generator, push the generator button or move the switch. The indicator light will turn off.

Platform Overload Indicator Light (if equipped)

Light flashing indicates the platform is overloaded and no functions will operate.

Remove weight from the platform until the light goes off.

Fall Protection

Personal fall protection equipment (PFPE) is required when operating this machine.

All PFPE must comply with applicable governmental regulations, and must be inspected and used in accordance with the PFPE manufacturer's instructions.

Aircraft Protection Package (if equipped)

If the platform bumper comes into contact with an object, the machine will shut down and no functions will operate.

- 1 Start the engine.
- 2 Press down the foot switch.
- 3 Activate the function override function. Move the switch or push the button.
- 4 Activate the appropriate function button, control handle or toggle switch to move the machine away from aircraft components.

OPERATING INSTRUCTIONS

After Each Use

- 1 Select a safe parking location—firm level surface, clear of obstruction and traffic.
- 2 Retract and lower the boom to the stowed position.
- 3 Rotate the turntable so that the boom is between the circle-end wheels.
- 4 Turn the key switch to the off position and remove the key to secure from unauthorized use.
- 5 Chock the wheels.

Transport and Lifting Instructions



Observe and Obey:

- ☑ Genie Industries provides this securement information as a recommendation. Drivers are solely responsible for making sure machines are properly secured and the correct trailer is selected pursuant to US Department of Transportation regulations, other localized regulations, and their company policy.
- ☑ Genie customers needing to containerize any lift or Genie product should source a qualified freight forwarder with expertise in preparing, loading and securing construction and lifting equipment for international shipment.
- ☑ Only qualified aerial lift operators should move the machine on or off the truck.
- ☑ The transport vehicle must be parked on a level surface.
- ☑ The transport vehicle must be secured to prevent rolling while the machine is being loaded.
- ☑ Be sure the vehicle capacity, loading surfaces and chains or straps are sufficient to withstand the machine weight. See the serial label for the machine weight.

- ☑ Be sure the turntable is secured with the turntable rotation lock before transporting. Be sure to unlock the turntable for operation.
- ☑ Do not drive the machine on a slope that exceeds the slope or side slope rating. See Driving on a Slope in the Operating Instructions section.
- ☑ If the slope of the transport vehicle bed exceeds the uphill or downhill maximum slope rating, the machine must be loaded and unloaded using a winch as described.

Free-wheel Configuration for Winching

Chock the wheels to prevent the machine from rolling.

Release the wheel brakes by turning over all four drive hub disconnect caps.

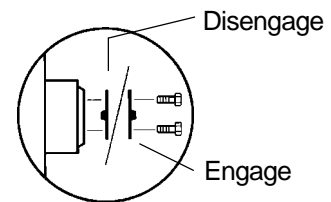

Be sure the winch line is properly secured to the drive chassis tie points and the path is clear of all obstructions.

Reverse the procedures described to re-engage the brakes.

Note: The pump free-wheel valve should always remain closed.

TRANSPORT AND LIFTING INSTRUCTIONS

Securing to Truck or Trailer for Transit

Always use the turntable rotation lock pin each time the machine is transported.

Turn the key switch to the off position and remove the key before transporting.

Inspect the entire machine for loose or unsecured items.

Securing the Chassis

Use chains of ample load capacity.

Use a minimum of 6 chains.

Adjust the rigging to prevent damage to the chains.

Securing the Platform

Place a block under the platform rotator. Do not allow the block to contact the platform cylinder.

Secure the platform with a nylon strap placed through the lower platform support. Do not use excessive downward force when securing the boom section.

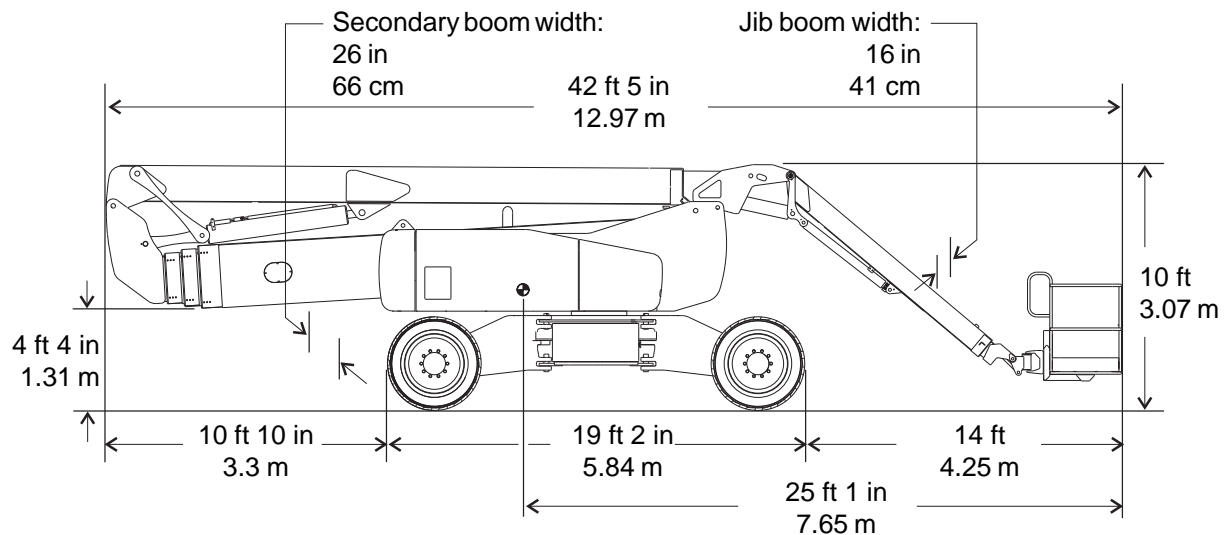
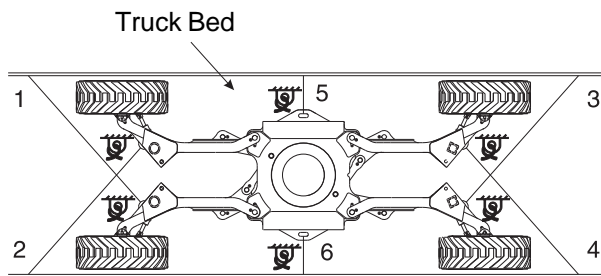
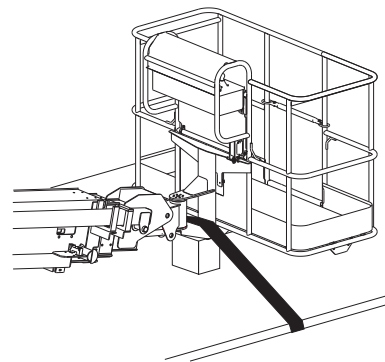

TRANSPORT AND LIFTING INSTRUCTIONS

**Observe and Obey:**

- ☑ Only qualified riggers should rig and lift the machine.
- ☑ Be sure the crane capacity, loading surfaces and straps or lines are sufficient to withstand the machine weight. See the serial label for the machine weight.

Lifting Instructions

Fully lower and retract the primary and secondary boom. Fully lower and retract the jib boom. Remove all loose items on the machine.

Determine the center of gravity of your machine using the picture on this page.

Attach the rigging only to the designated lifting points on the machine. There are four lifting points on the chassis.

Adjust the rigging to prevent damage to the machine and to keep the machine level.

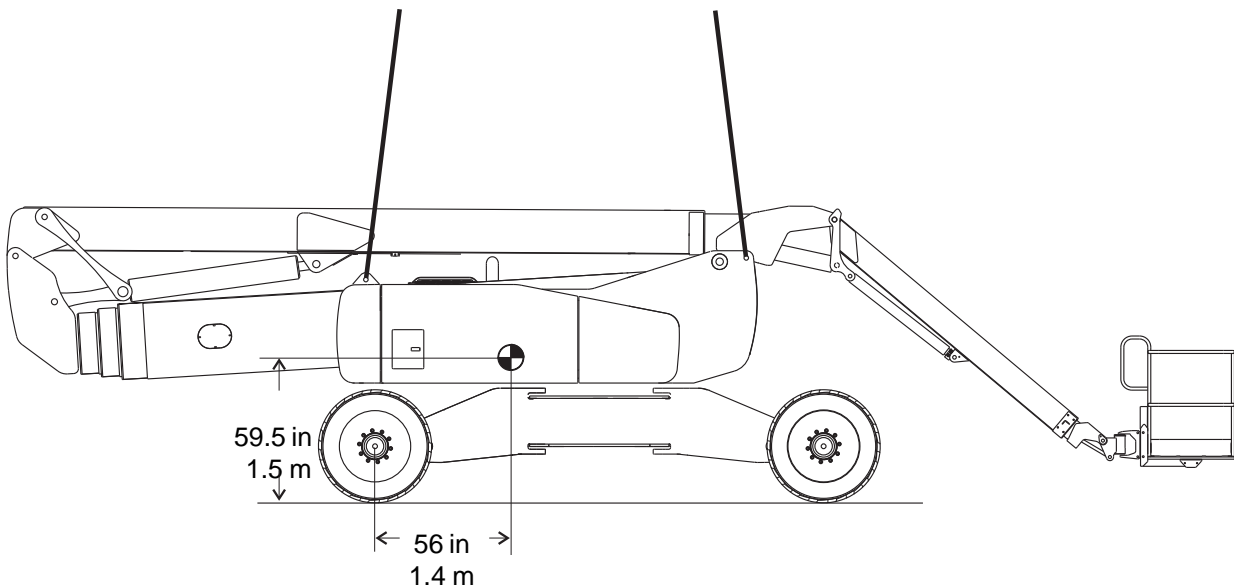

Decals

Inspection for Decals with Words

Determine whether the decals on your machine have words or symbols. Use the appropriate inspection to verify that all decals are legible and in place.

Part No.	Description	Quantity
25994	Caution - Component Damage Hazard	1
27204	Arrow - Blue	2
27205	Arrow - Yellow	2
27206	Triangle - Blue	2
27207	Triangle - Yellow	2
27564	Danger - Electrocutation Hazard	2
28159	Label - Diesel	1
28161	Warning - Crushing Hazard	2
28164	Notice - Hazardous Materials	1
28165	Notice - Foot Switch	1
28171	Label - No Smoking	1
28174	Label - Power to Platform, 230V	2
28176	Notice - Missing Manuals	1
28177	Warning - Collision Hazard	2
28181	Warning - No Step or Ride	1
28235	Label - Power to Platform, 115V	2
28236	Warning - Failure To Read . . .	1
31060	Danger - Tip-over Hazard	2
32998	Notice - Max. Capacity, 600 lbs / 272 kg	1
33952	Danger - Tip-over Hazard	1
40434	Label - Lanyard Anchorage	3
44981	Label - Air Line to Platform	2
44986	Notice - Max. Manual Force, 90 lbs / 400 N, Australia	1
65278	Caution - No Step	2

Part No.	Description	Quantity
82314	Danger - Tip-over Hazard	1
82422	Label - Driving Lights	1
82841	Platform Control Panel	1
97576	Notice - Engine Specifications, Deutz	1
97602	Warning - Explosion Hazard	1
97603	Notice - Engine Specifications, Perkins	1
97705	Cosmetic - Genie Z-135/70	1
97708	Label - Fuse and Relay Panel Layout	1
97715	Danger/Notice - Tire Specifications	4
97716	Label - Wheel Load	4
97757	Label - Hydraulic Oil Level	1
97864	Caution - Collision Hazard	1
97865	Warning - Electrocutation Hazard	2
97875	Warning - Weld Lines to Platform	2
97885	Notice - Operating Instructions	2
97887	Notice - Max. Side Force, 150 lbs / 667 N, ANSI & CSA	1
97890	Danger - General Safety	2
97889	Cosmetic - Z-135	2
97891	Cosmetic - Genie Z-135	1
102188	Notice - Engine Specifications, Cummins	1
233130	Platform Control Panel	1
1000257	Label - Transport Diagram	2
1000083	Notice - Start and Controls Battery	1
1000084	Caution - Auxiliary Batteries	1
1263543	Warning - Compartment Access	5
1263545	Label - Bypass Key Switch	1
1263556	Ground Control Panel	1



Shading indicates decal is hidden from view, i.e. under covers

DECALS

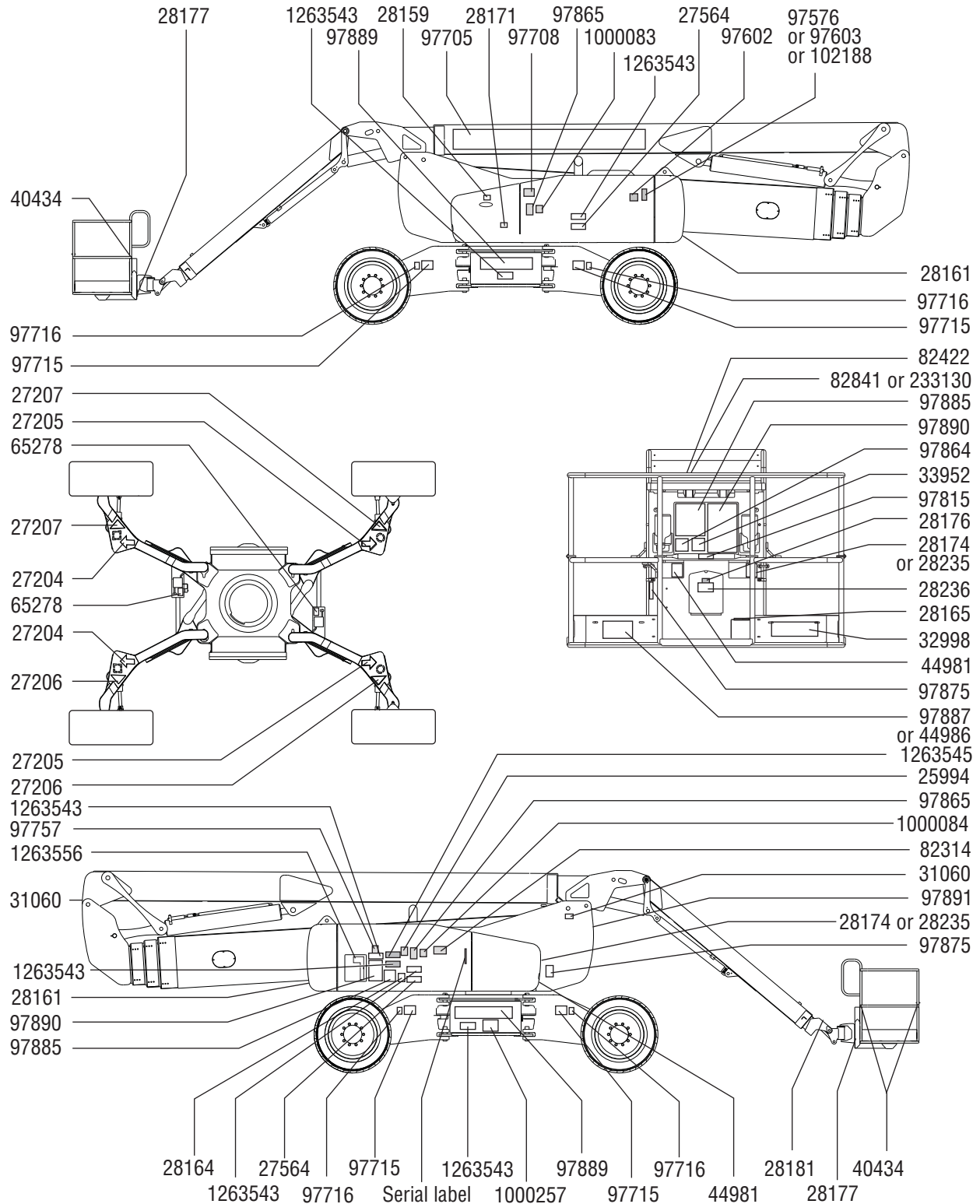

DECALS

Inspection for Decals with Symbols

Determine whether the decals on your machine have words or symbols. Use the appropriate inspection to verify that all decals are legible and in place.

Part No.	Description	Quantity
27204	Arrow - Blue	2
27205	Arrow - Yellow	2
27206	Triangle - Blue	2
27207	Triangle - Yellow	2
28159	Label - Diesel	1
28171	Label - No Smoking	1
28174	Label - Power to Platform, 230V	2
28235	Label - Power to Platform, 115V	2
40434	Label - Lanyard Anchorage	3
44981	Label - Air Line to Platform	2
82422	Label - Driving Lights	1
82472	Warning - Crushing Hazard	2
82487	Label - Read the Manual	2
82544	Danger - Electrocutation Hazard	2
82546	Notice - Max. Capacity, 272 kg	1
82548	Warning - Platform Rotate	2

Part No.	Description	Quantity
82602	Danger- Max. Side Force, 667 N, ANSI	1
82604	Danger- Max. Manual Force, 400 N, CE	1
82607	Caution - No Step	2
82671	Label - Weld Line to Platform	2
82841	Platform Control Panel	1
82924	Caution - Shut-off Valves	1
97705	Cosmetic - Genie Z-135/70	1
97716	Label - Wheel Load	4
97757	Label - Hydraulic Oil Level	1
97815	Label - Lower Mid-Rail	1
97889	Cosmetic - Z-135	2
97891	Cosmetic - Genie Z-135	1
233130	Platform Control Panel	1
1000257	Label - Transport Diagram	2
1000054	Label - Drive Enable Patch	1
1263542	Label - Compartment Access	5
1263545	Label - Bypass Key Switch	1
1263556	Ground Control Panel	1

DECALS

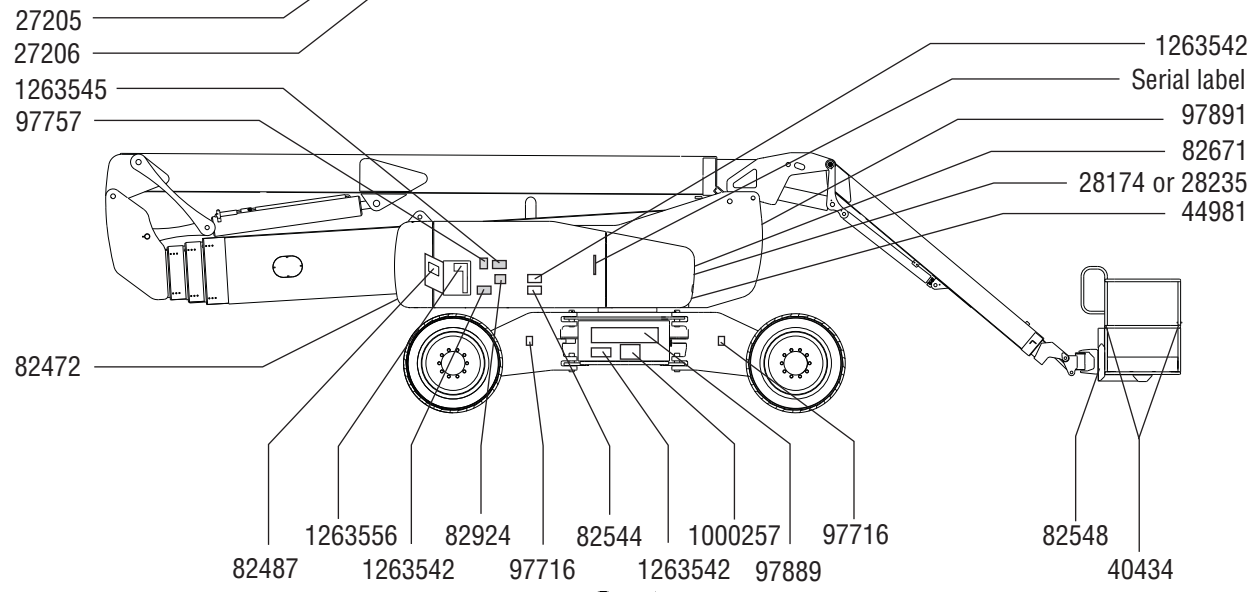
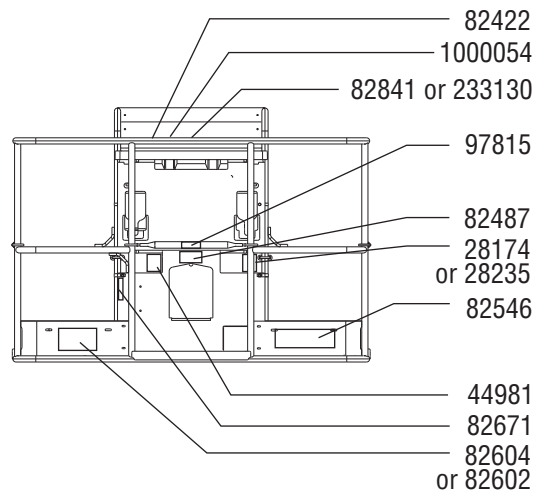
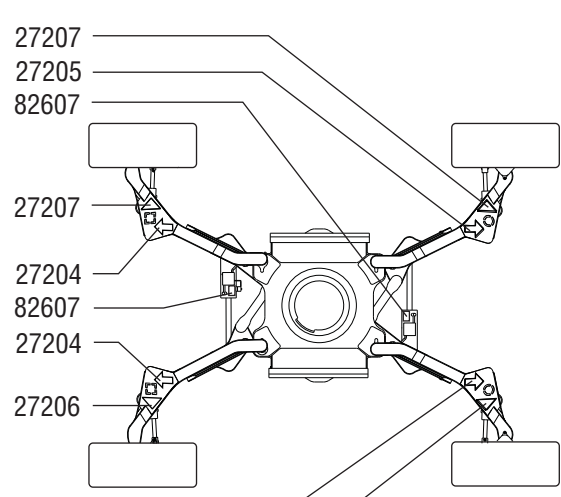
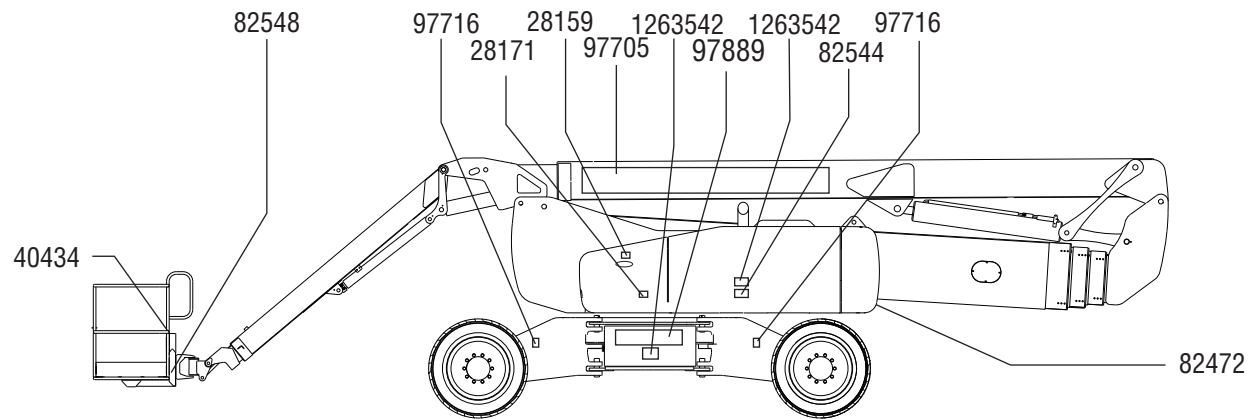

Specifications

Z-135/70

Height, working maximum	141 ft	42.9 m
Height, platform maximum	135 ft	41.1 m
Height, stowed maximum	10 ft 1 in	3.1 m
Horizontal reach, maximum	69 ft 9 in	21.3 m
Width, axles retracted	8 ft 1 in	2.5 m
Width, axles extended	12 ft 11 in	3.9 m
Length, stowed	42 ft 5 in	12.9 m
Maximum load capacity	600 lbs	272 kg
Maximum wind speed	28 mph	12.5 m/s
Wheelbase, axles extended	13 ft 6 in	4.1 m
Wheelbase, axles retracted	15 ft 6 in	4.7 m
Ground clearance	20 in	51 cm
Turning radius, axles extended inside	7 ft 6 in	2.3 m
outside	18 ft 6 in	5.6 m
Turning radius, axles retracted inside	18 ft 1 in	5.1 m
outside	25 ft 6 in	7.8 m
Turntable rotation	360° continuous	
Turntable tailswing, secondary boom lowered	14 ft	4.3 m
Turntable tailswing, secondary boom raised	2 ft 7 in	78 cm
Drive speed, stowed	3.0 mph 40 ft/9.1 sec	4.8 km/h 12.2 m/9.1 sec
Drive speed, raised or extended	0.7 mph 40 ft/40 sec	1.1 km/h 12.2 m/40 sec
Drive speed, raised and extended	0.4 mph 40 ft/68 sec	0.6 km/h 12.2 m/68 sec
Controls	12V DC proportional	
Platform dimensions, 6 foot (length x width)	72 in x 30 in 1.8 m x 76 cm	
Platform dimensions, 8 foot (length x width)	96 in x 36 in 2.4 m x 91 cm	

Platform leveling	self-leveling	
Platform rotation	160°	
AC outlet in platform	standard	
Hydraulic pressure, maximum (boom functions)	2900 psi 203 bar	
Hydraulic pressure, maximum (auxiliary power unit)	3100 psi 218 bar	
System voltage	12V	
Tire size	18-22.5, 18 ply FF	
Fuel tank capacity	40 gallons	151 liters
Weight (Machine weights vary with option configurations)	See Serial Label	
Airborne noise emissions Maximum sound level at normal operating workstations (A-weighted)	113 dB	

Maximum slope rating, stowed position

Counterweight uphill	45% (24°)
Counterweight downhill	30% (17°)
Side slope	25% (14°)

Note: Slope rating is subject to ground conditions and adequate traction.

Floor loading information

Tire load, maximum	25,000 lbs	11,340 kg
Tire contact pressure	130 psi	9.14 kg/cm ² 896 kPa
Occupied floor pressure	204 psf	996 kg/m ² 9.76 kPa

Note: Floor loading information is approximate and does not incorporate different option configurations. It should be used only with adequate safety factors.

Continuous improvement of our products is a Genie policy. Product specifications are subject to change without notice or obligation.

SPECIFICATIONS

Z-135/70 Range of Motion

